



HIGH DIRECTIVITY

# Monolithic Amplifier

## MNA-6A+

50Ω 0.5 to 2.5 GHz

### THE BIG DEAL

- Integrated matching, DC Blocks and bias circuits
- Excellent Active Directivity, 13-22 dB typ.
- Choice of supply voltage, 2.8V to 5V
- Micro-miniature size .120"X.120"
- Low noise figure, 2.7 dB typ. at 2 GHz
- Output power, up to +20 dBm typ.
- Aqueous washable

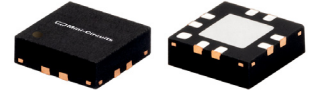

Generic photo used for illustration purposes only

CASE STYLE: DQ849

### +RoHS Compliant

The +Suffix identifies RoHS Compliance. See our website for methodologies and qualifications

### APPLICATIONS

- Buffer amplifier
- Cellular
- PCN
- Communications satellite
- Defense

### PRODUCT OVERVIEW

MNA-6A+ is a wideband PHEMT based MMIC amplifier with high active Directivity. MNA integrates the entire matching network and majority of the bias circuit inside the package, reducing the need for complicated external circuits. This approach makes the MNA amplifier extremely straightforward to use. This design operates on a single 2.8 to 5V supply, is well matched for 50Ω and comes in a tiny, low profile 3x3mm 8-lead MCLP package accommodating dense circuit board layouts.

### KEY FEATURES

Feature	Advantages
Excellent Active Directivity (Isolation- Gain) 13-22 dB	Ideal for use as a buffer amplifier minimizing interaction of adjacent circuits
Integrates DC blocks and RF choke	Minimizes external components, component count and circuit area.
Single 2.8 to +5V operation	Amplifier can be used at low voltage such as +3V or standard +5V. +5V operation results in higher P1dB and OIP3.
3 x 3mm 8-lead MCLP package	Tiny footprint saves space in dense layouts while providing low inductance, repeatable transitions, and excellent thermal contact to the PCB.

REV. A  
ECO-011187  
MCL NY  
221003





HIGH DIRECTIVITY

# Monolithic Amplifier

## MNA-6A+

### ELECTRICAL SPECIFICATIONS<sup>1</sup> AT 25°C

Parameter	Condition (GHz)	Vs=5V			Vs=2.8V Typ.	Units
		Min.	Typ.	Max.		
Frequency Range		0.5		2.5	0.5-2.5	GHz
Gain	0.5		22.3		20.4	dB
	0.75		24.4		22.0	
	1.0		25.0		22.3	
	1.5		25.3		22.3	
	2.0	22.3	24.8	27.3	21.6	
	2.5		23.2		20.4	
Input Return Loss	0.5		6.3		6.9	dB
	0.75		10.9		11.2	
	1.0		14.2		13.9	
	1.5		17.4		16.3	
	2.0		17.6		17.5	
	2.5		14.9		15.4	
Output Return Loss	0.5		10.9		9.8	dB
	0.75		17.8		13.3	
	1.0		27.2		14.9	
	1.5		24.1		15.3	
	2.0		19.5		14.8	
	2.5		19.4		15.2	
Output Power at P1dB	0.5		20.3		11.1	dBm
	0.75		20.3		11.6	
	1.0		20.2		11.9	
	1.5		19.9		11.8	
	2.0		19.4		12.2	
	2.5		19.2		12.5	
Output IP3	0.5		33.2		22.8	dBm
	0.75		33.0		23.3	
	1.0		32.4		23.7	
	1.5		31.4		23.5	
	2.0		30.4		23.8	
	2.5		30.0		24.1	
Noise Figure (dB)	0.5		3.1		3.2	dB
	0.75		2.8		2.9	
	1.0		2.6		2.7	
	1.5		2.6		2.7	
	2.0		2.7		2.7	
	2.5		2.7		2.8	
Directivity (Isolation-Gain)	0.5		22.1		24.9	dB
	0.75		21.1		22.0	
	1.0		18.7		19.2	
	1.5		15.1		15.5	
	2.0		13.3		13.6	
	2.5		13.2		13.0	
DC Current			99	110	92	mA
Device Current Variation vs. Temperature <sup>(2)</sup>			41		37	µA/°C
Device Current Variation vs Voltage			0.0017 <sup>(3)</sup>		0.0044 <sup>(4)</sup>	mA/mV
Thermal resistance at 85°C (Junction to Lead)			46		46	°C/W

(1) Measured on Mini-Circuits Characterization test board TB-186+. See Characterization Test Circuit (Fig. 1)

(2) (Current at 85°C - Current at -45°C)/130

(3) (Current at 5.25V - Current at 3.9V)/1.35

(4) (Current at 3.9V - Current at 2.66V)/1.24



### MAXIMUM RATINGS<sup>5</sup>

Parameter	Ratings
Operating Temperature	-40°C to 85°C
Storage Temperature	-55°C to 100°C
DC Voltage	7V at pad 7 (on TB-186+) 1V at pads 2 & 5
Power Dissipation	970 mW
Input Power	10dBm (continuous operation) 26dBm (5 minutes max)

5. Permanent damage may occur if any of these limits are exceeded. These ratings are not intended for continuous normal operation.

### SIMPLIFIED SCHEMATIC AND PAD DESCRIPTION

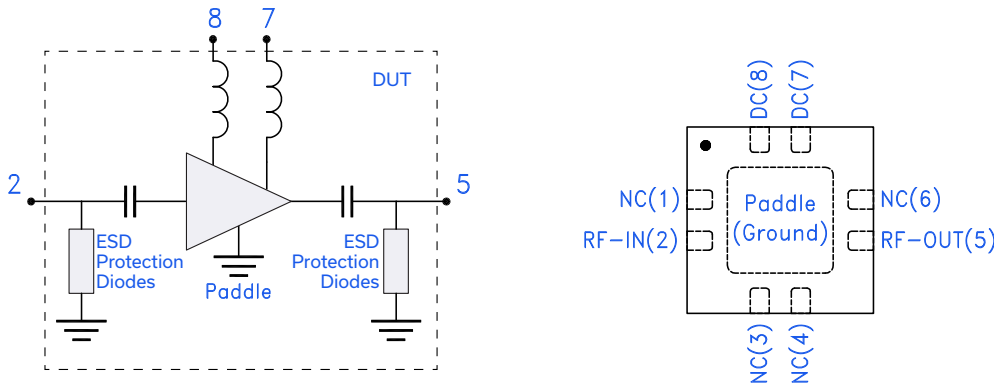

Function	Pad Number	Description (See Fig 1)
RF-IN	2	RF input pin
RF-OUT	5	RF output pin
DC	7,8	DC Bias pads 7,8. Pad 7 connected to ground via 1000 pF. Pad 8 connected to pad 7 via 33.2 ohms.
NC	1,3,4,6	Not Connected, connect pad 3 and 4 to ground externally
GND	Paddle	Ground
OPTIONAL	1,6	No internal connection; recommended use: per PCB Layout PL-078



## CHARACTERIZATION & APPLICATION TEST CIRCUIT

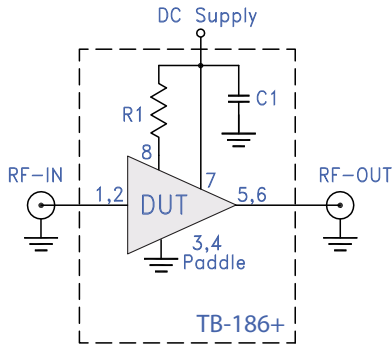

Fig 1. Block Diagram of Test Circuit used for characterization. (DUT soldered on Mini-Circuits Characterization test board TB-313)

Gain, Return loss, Output power at 1dB compression (P1 dB) , output IP3 (OIP3) and noise figure measured using Agilent's N5242A PNA-X microwave network analyzer.

Conditions:

1. Gain and Return loss: Pin= -25dBm
2. Output IP3 (OIP3): Two tones, spaced 1 MHz apart, 0 dBm/tone at output.

Component	Size	Value	Units
R1	0805	33.2	$\Omega$
C1	0402	1000	$\rho F$

## RECOMMENDED APPLICATION CIRCUIT

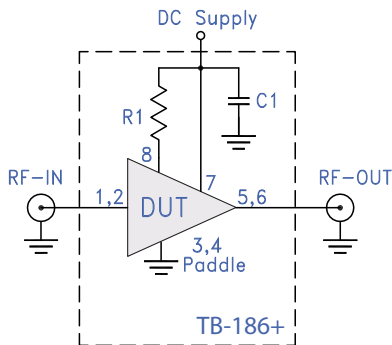
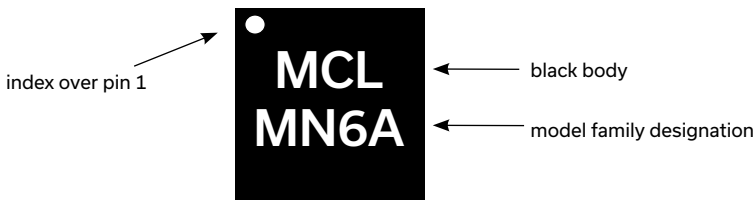

Fig 2. Test Board includes case, connectors, and components soldered to PCB

Component	Size	Value	Units
R1	0805	33.2	$\Omega$
C1	0402	1000	$\rho F$

## PRODUCT MARKING



Marking may contain other features or characters for internal lot control