

GaAs MMIC High Dynamic Range Mixer

MT3-0113LCQG

Page 1

The MT3-0113LCQG is a triple balanced passive diode GaAs MMIC mixer offering high dynamic range, low conversion loss, and excellent repeatability. As with all T3 mixers, this mixer offers unparalleled nonlinear performance in terms of IIP3, P_{1dB}, and spurious performance with a flexible LO drive requirement from +11 dBm to +24 dBm. The MT3-0113LCQG is available in a surface-mount outline, or in an SMA connectorized evaluation fixture. The MT3-0113LCQG is a superior alternative to Marki Microwave carrier and packaged T3 mixers, and is form-fit compatible with legacy T3's in the CQ and CQG footprints. For a list of recommended LO driver amps for all mixers and IQ mixers, see [here](#).

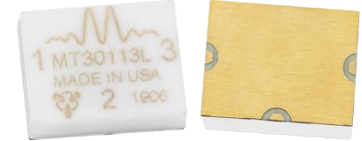

Features

- Form-Fit Compatible with Legacy CQ and CQG T3 Mixers
- Broadband, Overlapping RF, LO and IF
- Suitable for Up or Down Conversion
- Compatible with Sine or Square-Wave LO
- Square-Wave LO delivers Industry-Leading Spurious, IP3, and P_{1dB} Performance
- Application Note: [T3 Mixer Primer](#)

Electrical Specifications - Specifications guaranteed over -40 to +100°C temperature range, measured in a 50Ω system. Specifications are shown for Configurations A (B). See page 2 for port locations. Consult factory for more information.

Parameter	LO (GHz)	RF (GHz)	IF (GHz)	Min	Typ	Max	LO drive level (dBm)	
Conversion Loss (dB) ¹	1.5-13	1.5-13	0.01-0.5		7.5 (7.5)	10.5	+15 (+15)	
			0.5-7.0		10 (10)			
Isolation (dB) LO-RF LO-IF RF-IF						See Plots		
Input 1 dB Compression (dBm) ²				0.01-7		See Plots		Config. A: +11 to +24 Config. B: +11 to +24
Input Two-Tone Third Order Intercept Point (dBm) ³					+24 +23		Config. A: +11 to +24 Config. B: +11 to +24	

¹Unless otherwise specified, Conversion Loss and Spurious data is measured with a 100 MHz fixed IF.

²P_{1dB} is typically within 1-2 dB of LO drive power.

³The typical value is for a +15 dBm Sine-Wave LO. IP3 is dependent on LO drive and waveform. See plots and data sheet notes on page 10 for more details.

Part Number Options

Model Number	Description
MT3-0113LCQG-2 ¹	RoHS Compliant Surface Mount, IF Port Configuration -2
EVAL-MT3-0113L	Connectorized Evaluation Fixture

¹Note: For port locations and I/O designations, refer to the drawings on page 2 of this document.

GaAs MMIC High Dynamic Range Mixer

MT3-0113LCQG

Page 2

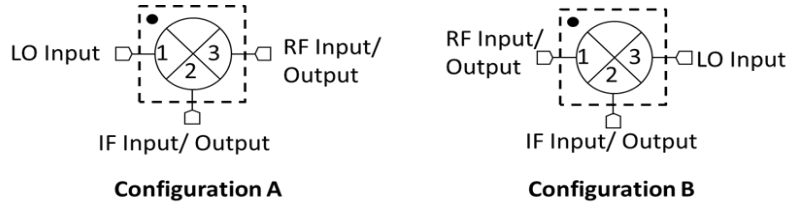

1. Configuration A/B refer to the same part number (MT3-0113LCQG) used in one of two different ways for optimal spurious performance. For the lowest conversion loss, use the mixer in Configuration A (port 1 as the LO input, port 3 as the RF input or output). If you need to use a lower LO drive, use the mixer in Configuration B (port 1 as the RF input or output, port 3 as the LO input). For optimal spurious suppression, experimentation or simulation is required to choose between Configuration A and B. For more information, [see here](#).

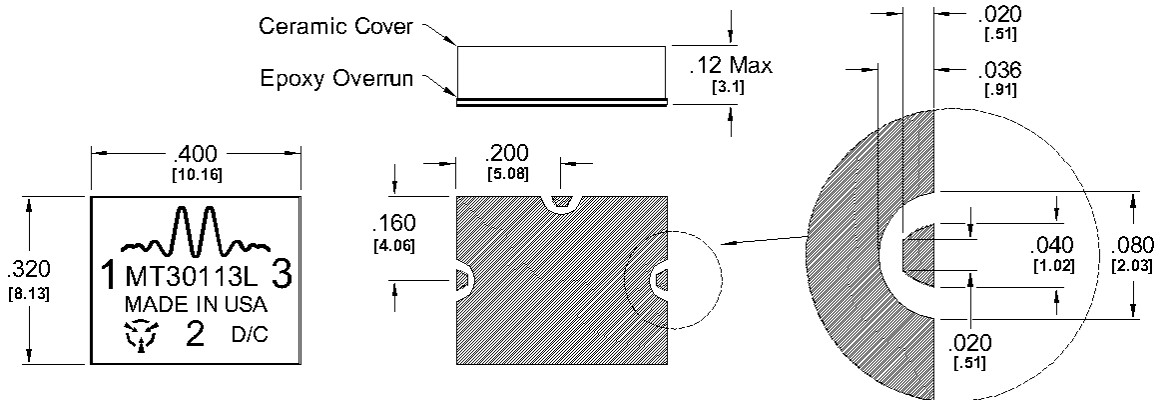

I/O Connections & Ground Plane Finish is Gold Flash, 5 to 10 μ-inches, over Solderable Nickel, 100-200 μ-inches, over Cu.

Outline Drawing – CQG-2 Package

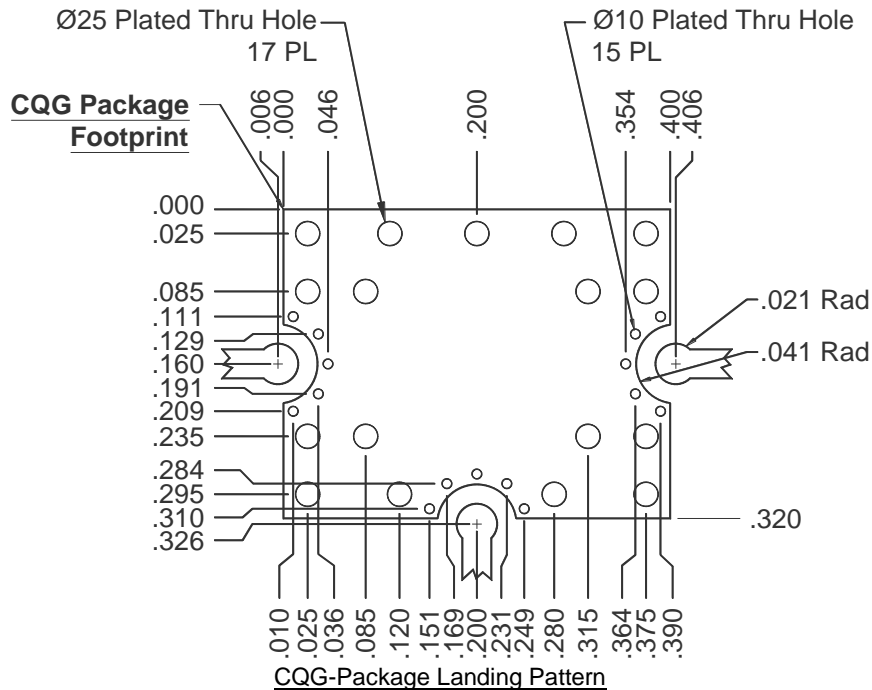

[Click here for a DXF of the above layout.](#)
[Click here for leaded solder reflow.](#) [Click here for lead-free solder reflow.](#)

GaAs MMIC High Dynamic Range Mixer

MT3-0113LCQG

Page 3

Typical Performance

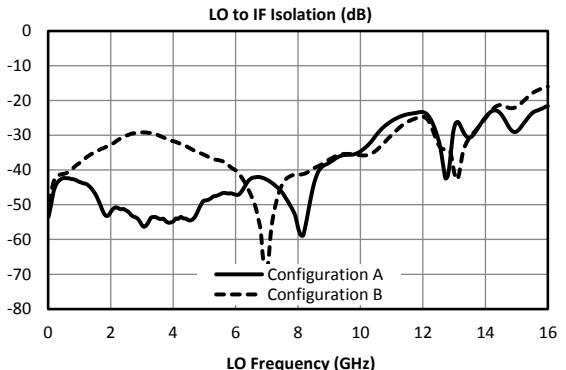
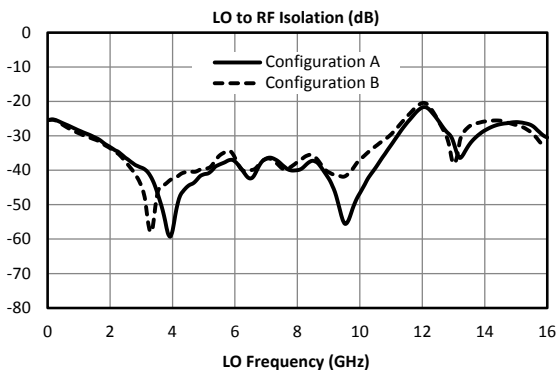
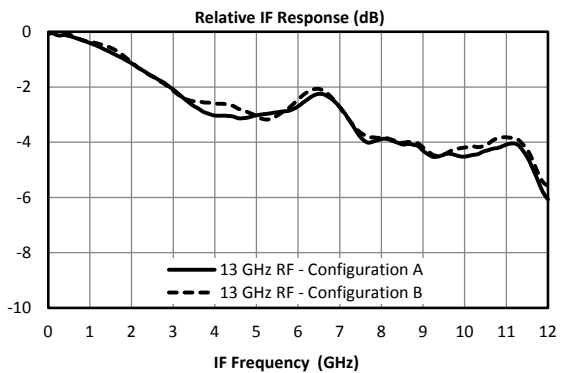
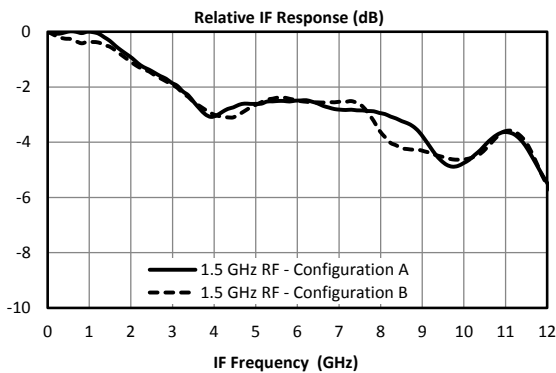
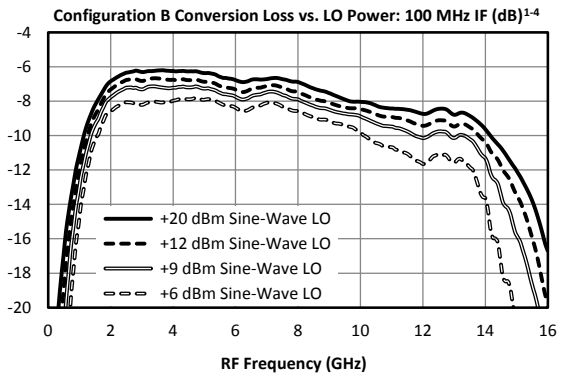
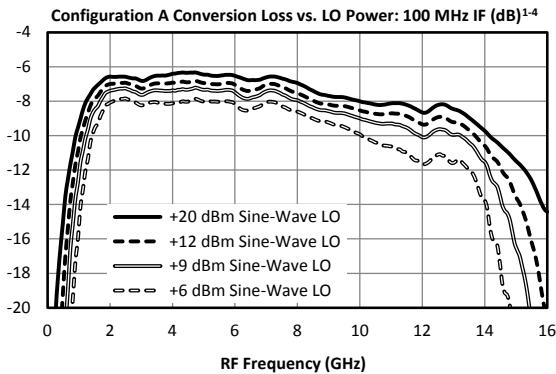
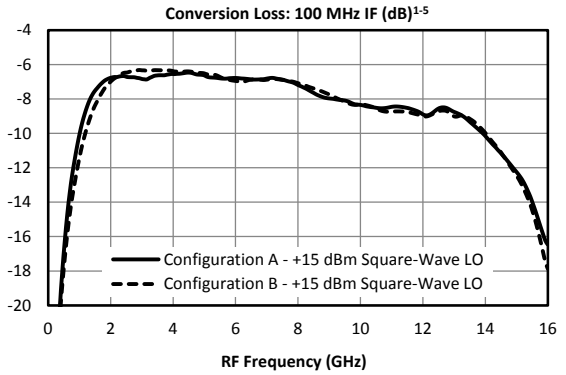
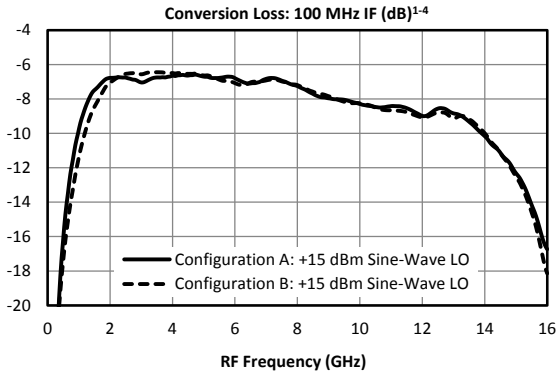

GaAs MMIC High Dynamic Range Mixer

MT3-0113LCQG

Page 4

Typical Performance

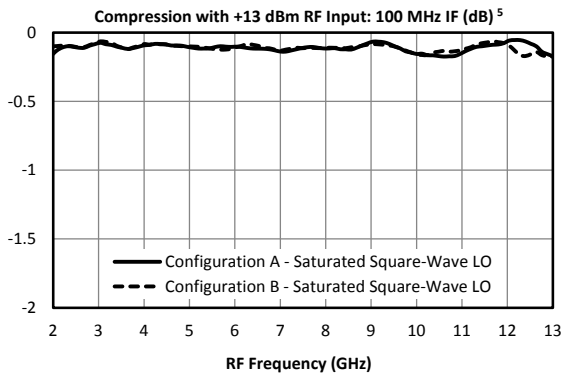
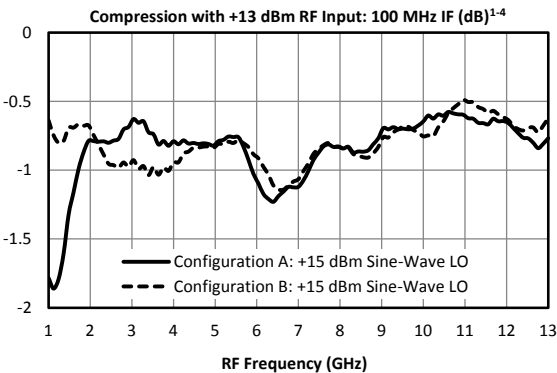
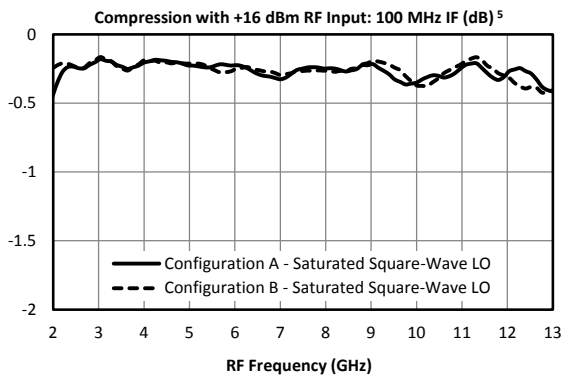
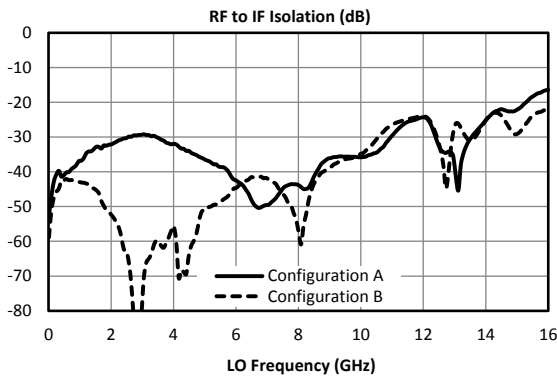
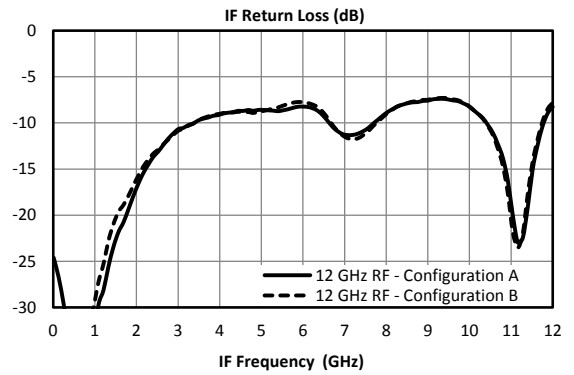
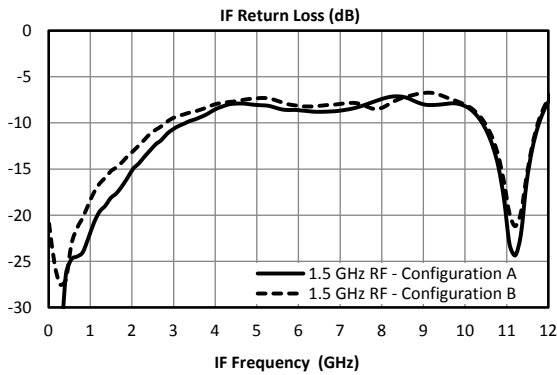
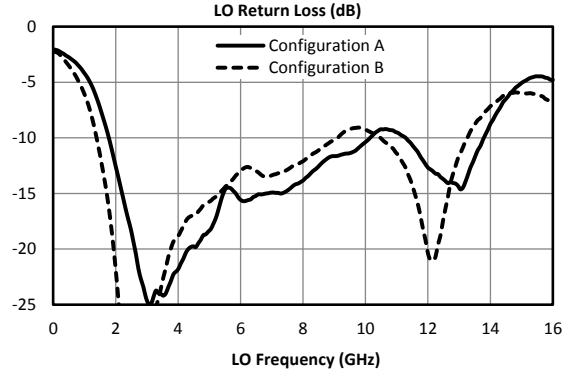
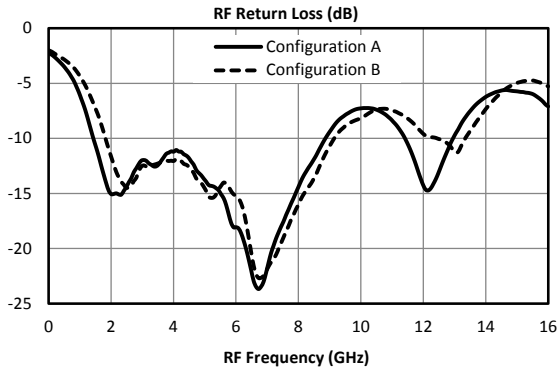

GaAs MMIC High Dynamic Range Mixer

MT3-0113LCQG

Page 5

Typical Performance

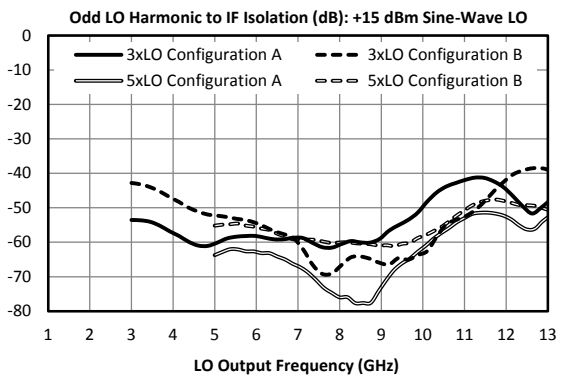
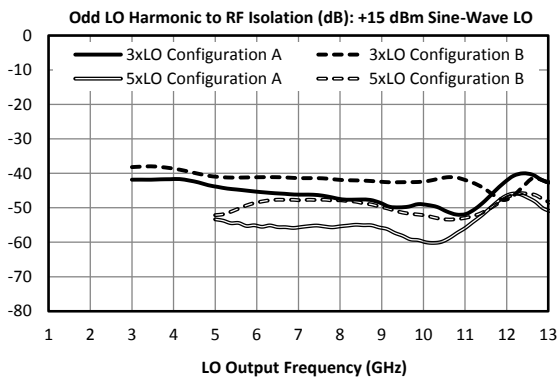
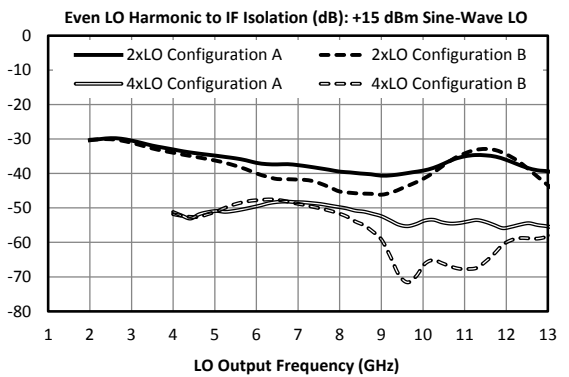
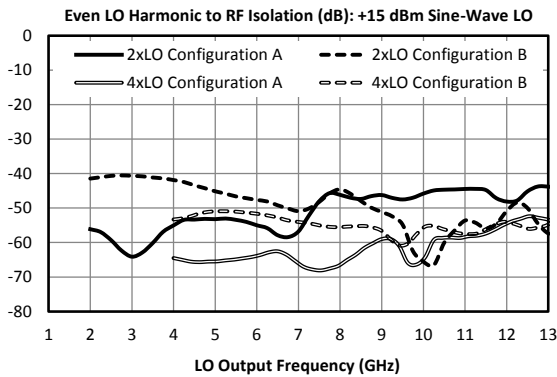
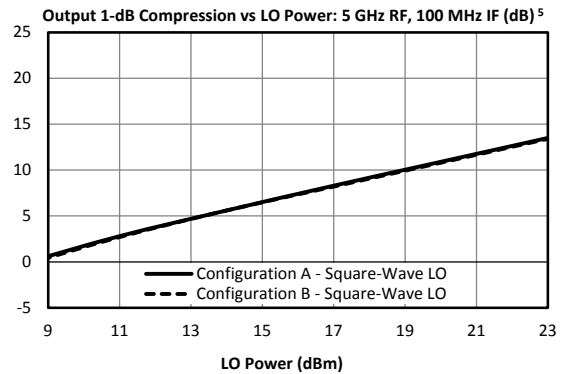
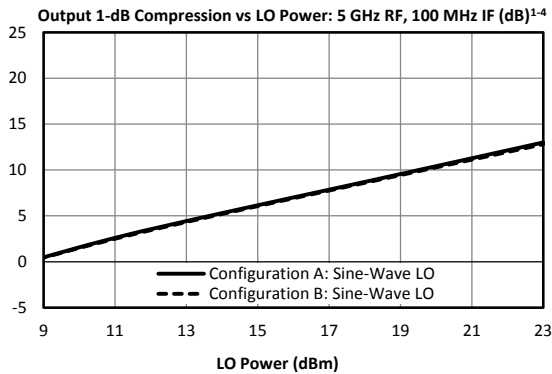
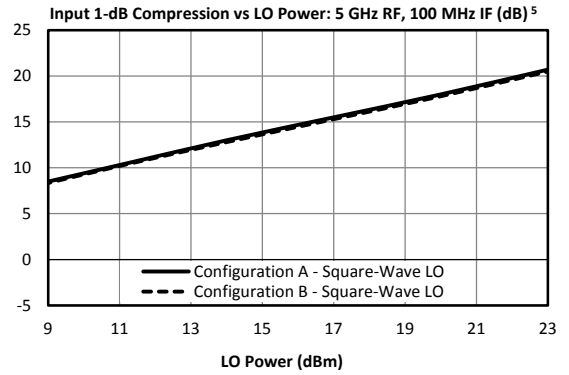
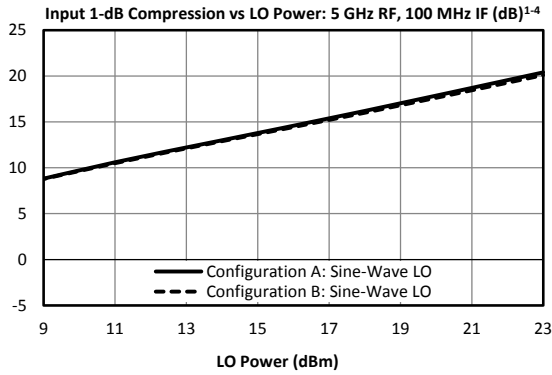

GaAs MMIC High Dynamic Range Mixer

MT3-0113LCQG

Page 6

Typical Performance

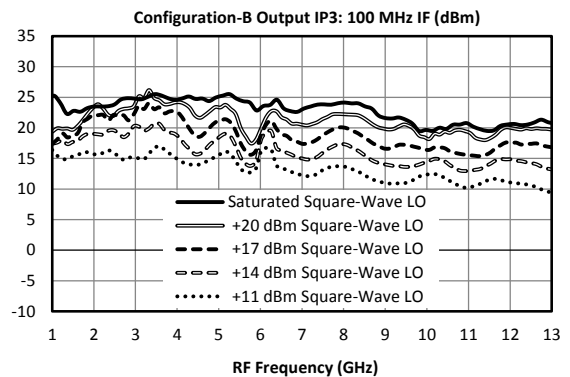
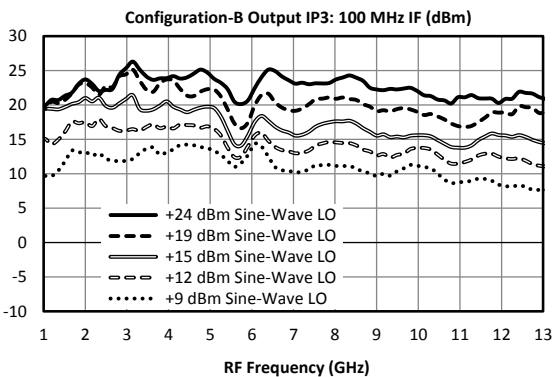
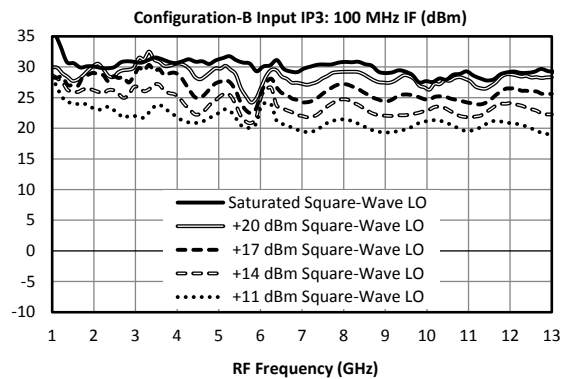
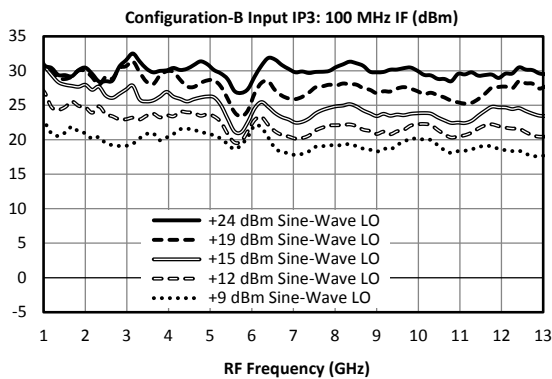
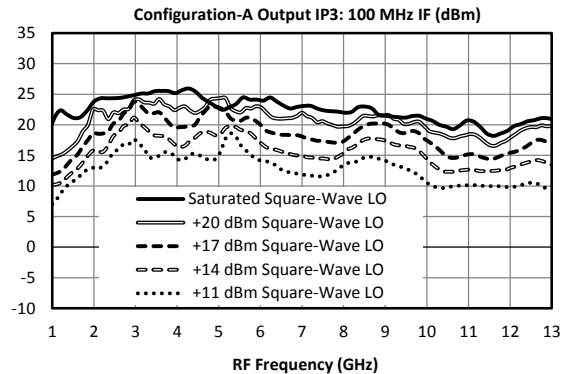
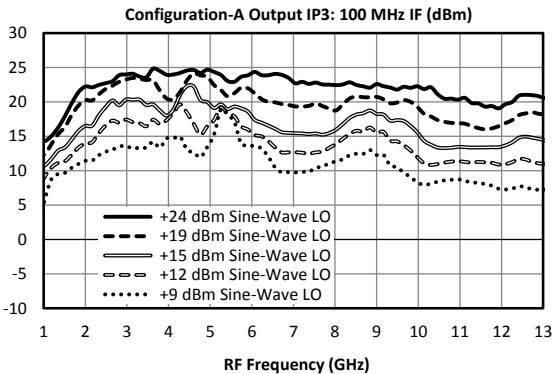
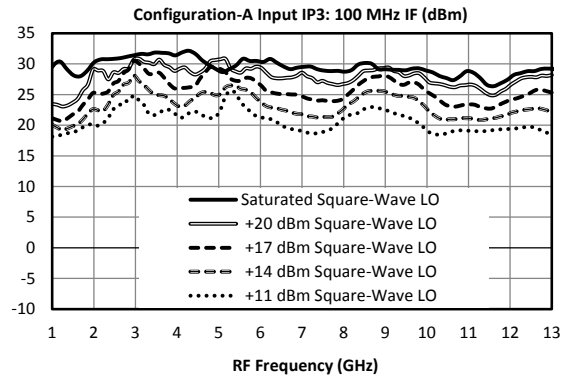
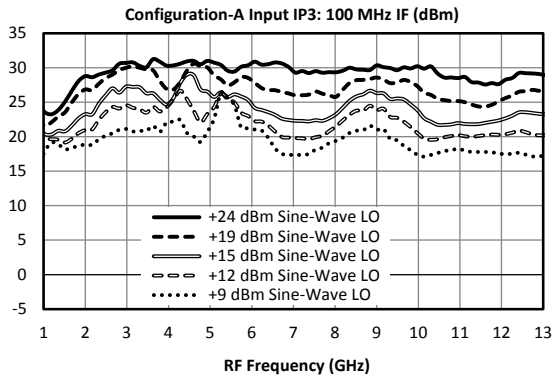

GaAs MMIC High Dynamic Range Mixer

MT3-0113LCQG

Page 7

Typical Performance

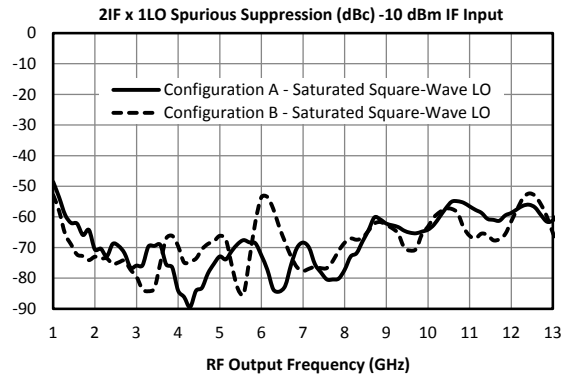
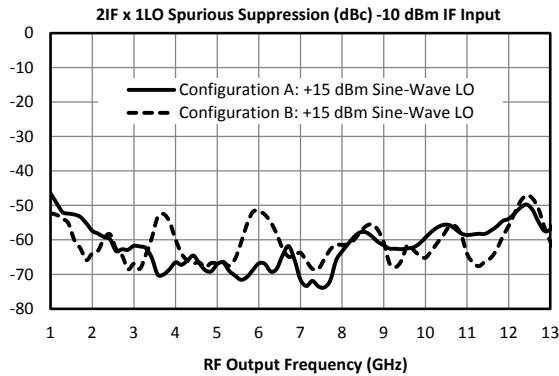
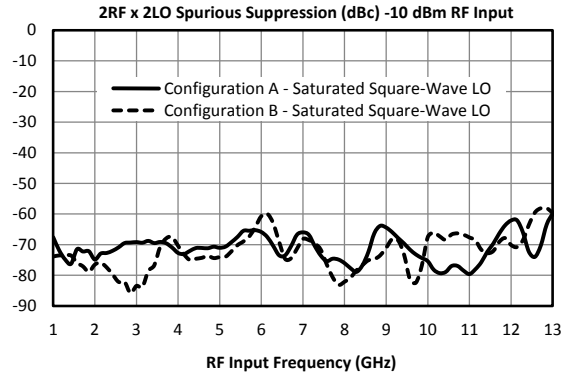
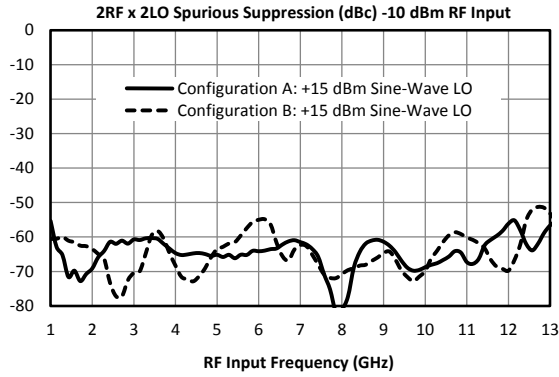



GaAs MMIC High Dynamic Range Mixer

MT3-0113LCQG

Page 8

Downconversion Spurious Suppression

Spurious data is taken by selecting RF and LO frequencies ($\pm mLO \pm nRF$) within the RF/LO bands, to create a spurious output within the IF band. The mixer is swept across the full spurious band and the mean is calculated. The numbers shown in the table below are for a -10 dBm RF input. Spurious suppression is scaled for different RF power levels by $(n-1)$, where “n” is the RF spur order. For example, the $2RF \times 2LO$ spur is 65 dBc for the A configuration for a -10 dBm input with a sine-wave LO, so a -20 dBm RF input creates a spur that is $(2-1) \times (-10 \text{ dB})$ dB lower, or 75 dBc.

Typical Downconversion Spurious Suppression (dBc): A Configuration (B Configuration), Sine Wave LO ⁶

-10 dBm RF Input	0xLO	1xLO	2xLO	3xLO	4xLO	5xLO
1xRF	29 (33)	Reference	42 (43)	14 (14)	44 (50)	26 (27)
2xRF	63 (65)	67 (65)	65 (65)	70 (67)	63 (62)	71 (65)
3xRF	112 (112)	74 (74)	91 (94)	74 (75)	92 (96)	76 (77)
4xRF	117 (121)	117 (118)	114 (113)	120 (118)	116 (111)	120 (117)
5xRF	152 (146)	127 (130)	140 (141)	125 (127)	139 (140)	126 (128)

Typical Downconversion Spurious Suppression (dBc): A Configuration (B Configuration), Square Wave LO ⁶

-10 dBm RF Input	0xLO	1xLO	2xLO	3xLO	4xLO	5xLO
1xRF	30 (33)	Reference	26 (26)	11 (11)	25 (25)	17 (17)
2xRF	64 (71)	70 (67)	71 (72)	71 (73)	68 (64)	73 (73)
3xRF	112 (113)	88 (85)	99 (101)	86 (87)	98 (102)	91 (91)
4xRF	130 (130)	127 (127)	126 (121)	130 (127)	129 (130)	133 (134)
5xRF	166 (169)	146 (148)	151 (146)	146 (144)	151 (152)	151 (151)

Upconversion Spurious Suppression

Spurious data is taken by mixing an input within the IF band, with LO frequencies ($\pm mLO \pm nIF$), to create a spurious output within the RF output band. The mixer is swept across the full spurious output band and the mean is calculated. The numbers shown in the table below are for a -10 dBm IF input. Spurious suppression is scaled for different IF input power levels by $(n-1)$, where “n” is the IF spur order. For example, the 2IFx1LO spur is typically 62 dBc for the A configuration for a -10 dBm input with a sine-wave LO, so a -20 dBm IF input creates a spur that is $(2-1) \times (-10)$ dB lower, or 72 dBc.

Typical Upconversion Spurious Suppression (dBc): A Configuration (B Configuration), Sine Wave LO ⁶

-10 dBm IF Input	0xLO	1xLO	2xLO	3xLO	4xLO	5xLO
1xIF	26 (35)	Reference	40 (46)	14 (14)	44 (47)	25 (26)
2xIF	70 (63)	62 (61)	66 (62)	62 (61)	70 (62)	61 (60)
3xIF	112 (112)	72 (72)	89 (97)	70 (69)	88 (96)	70 (68)
4xIF	124 (124)	112 (108)	121 (112)	108 (107)	122 (106)	104 (104)
5xIF	145 (137)	126 (124)	133 (138)	118 (117)	130 (136)	108 (107)

Typical Upconversion Spurious Suppression (dBc): A Configuration (B Configuration), Square Wave LO ⁶

-10 dBm IF Input	0xLO	1xLO	2xLO	3xLO	4xLO	5xLO
1xIF	28 (35)	Reference	27 (27)	11 (11)	25 (25)	17 (17)
2xIF	77 (69)	69 (68)	65 (66)	67 (68)	64 (66)	62 (69)
3xIF	112 (113)	84 (84)	97 (98)	83 (84)	94 (95)	82 (83)
4xIF	135 (138)	125 (123)	122 (123)	129 (130)	119 (124)	123 (126)
5xIF	154 (154)	146 (146)	151 (153)	149 (148)	151 (152)	132 (137)