

GaAs MMIC DOUBLER

MMD-1030HSM

The MMD-1030HSM is a passive double balanced MMIC doubler covering 10 to 30 GHz on the output. It features excellent conversion loss, superior isolations and harmonic suppressions across a broad bandwidth, in a small form factor. The MMD-1030HSM is available in a lead-free, RoHS compliant QFN surface mount package and is compatible with standard leaded and lead-free PCB reflow soldering processes. The MMD-1030HSM is a superior alternative to Marki Microwave carrier and packaged doublers.

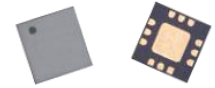

- Compact 3mm QFN SMT Style Package
- Broadband Performance
- Excellent Unit-to-Unit Repeatability
- RoHS Compliant

Electrical Specifications - Specifications guaranteed from -55 to +100°C, measured in a 50Ω system. All bare die are 100% DC tested and 100% visual inspected. RF testing is performed on a sample basis to verify conformance to datasheet guaranteed specifications. Consult factory for more information.

Parameter	Input (GHz)	Output (GHz)	Min	Typ	Max	Diode Option Input drive level (dBm)
2F (out) Conversion Loss (dB)	5-15	10-30		12		
Suppressions ¹						
1F (in) Fundamental				34		
3F (out) Third Harmonic				46		
4F (out) Fourth Harmonic				19		
Isolations ¹						
1F (in) Fundamental				46		
3F (out) Third Harmonic				57		
4F (out) Fourth Harmonic				31		
1F Input Level			+10	+14	+17	H-Version

¹ Suppression is relative to doubled output power. Isolation is defined as relative to the fundamental input power.

Part Number Options

Model Number	Description
MMD-1030HSM ¹	Surface Mount
EVAL-MMD-1030H	Connectorized Evaluation Fixture

¹ Note: For port locations and I/O designations, refer to the drawings on page 2 of this document.

GaAs MMIC DOUBLER

Page 2

MMD-1030HSM

Input 5 to 15 GHz
Output 10 to 30 GHz

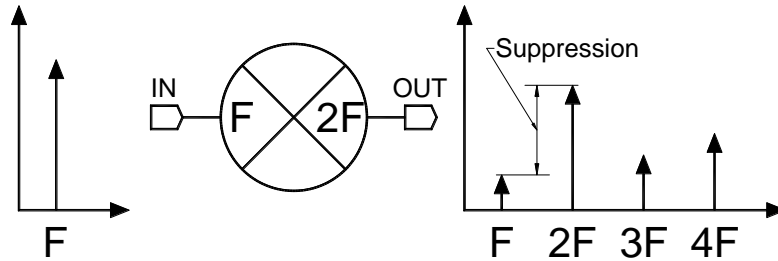

Typical Performance

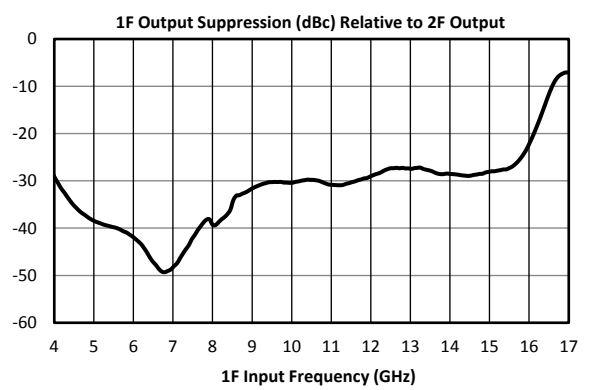
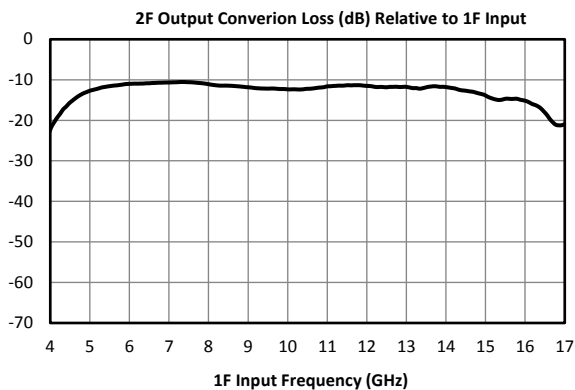
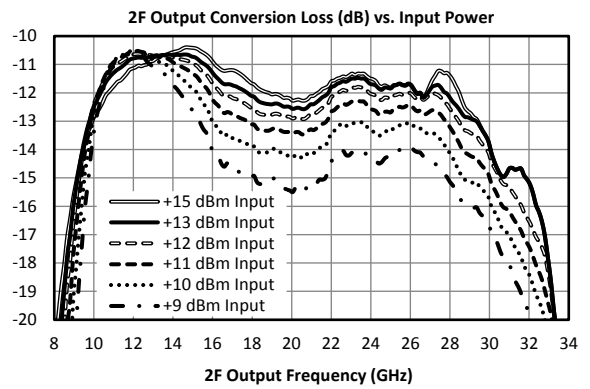
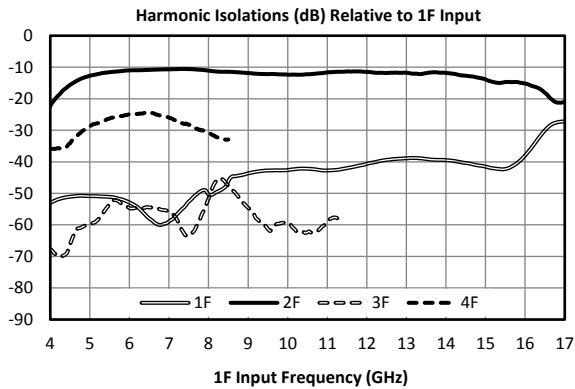

GaAs MMIC DOUBLER

Page 3

MMD-1030HSM

Input 5 to 15 GHz
Output 10 to 30 GHz

Typical Performance (cont.)

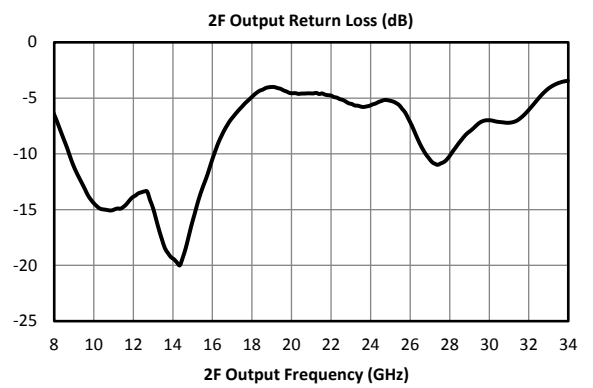
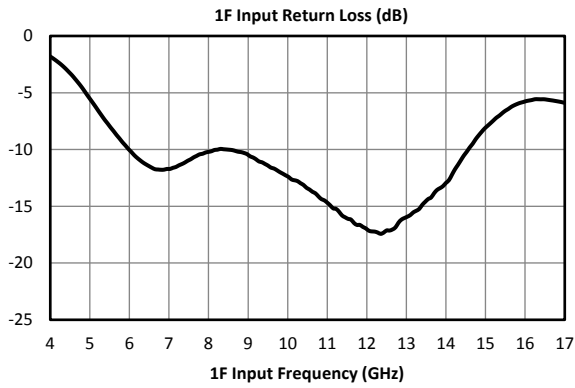
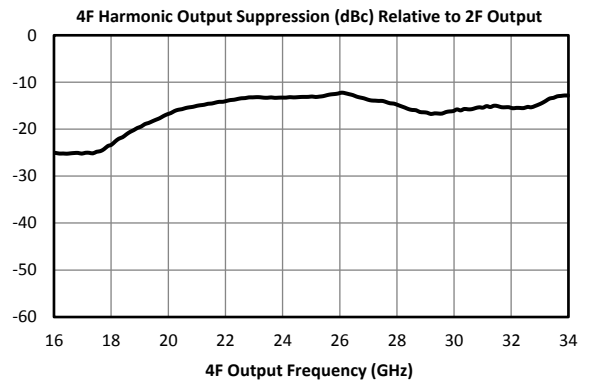
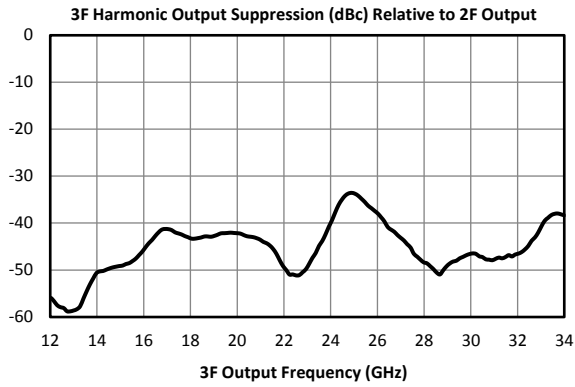

GaAs MMIC DOUBLER

Page 4

MMD-1030HSM

Input 5 to 15 GHz
Output 10 to 30 GHz

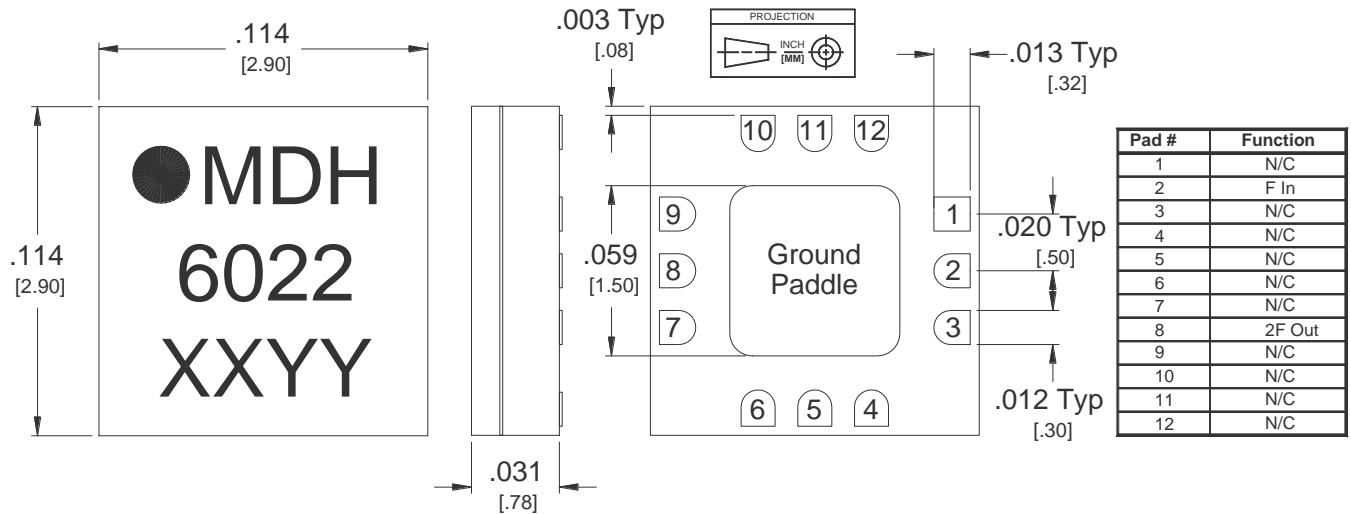

Outline Drawing – 3mm QFN package

Substrate material is Ceramic.

I/O Leads and Ground Paddle are 1.4±0.6 microns (55±24 micro-inches) Au over 1.3 microns (51 micro-inches) Ni.

All unconnected pads should be connected to PCB RF ground.

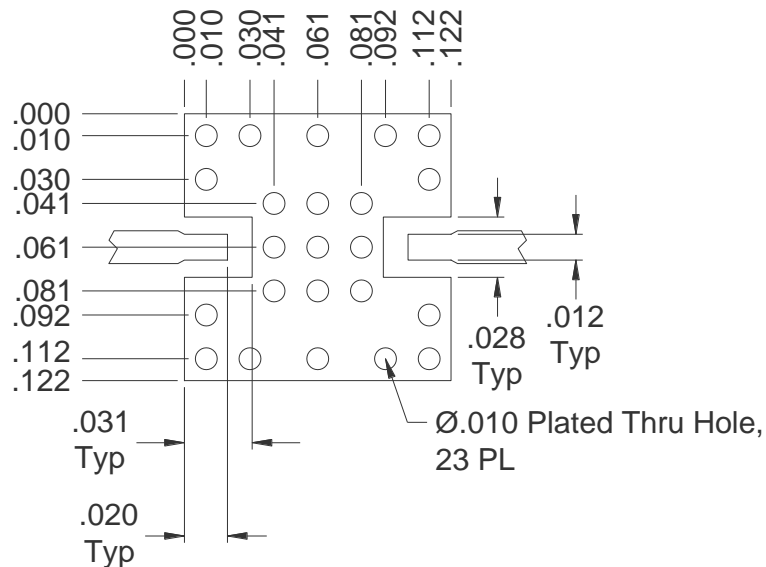

QFN-Package Doubler Surface-Mount Landing Pattern

[Click here for a DXF of the above layout.](#)

[Click here for leaded solder reflow.](#) [Click here for lead-free solder reflow.](#)