



MMIC SURFACE MOUNT WIDEBAND

Double Balanced Mixer

MDB-44H+

Level 15 (LO Power 15dBm) 10-40 GHz

THE BIG DEAL

- Wide bandwidth 10 to 40 GHz
- High L-R Isolation, 37 dB typ. at 25 GHz
- Useable as Up & Down Converter
- Small Size, 3 mm x 3 mm x 0.89 mm
- Aqueous washable

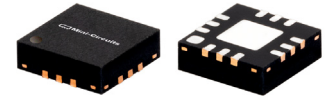

CASE STYLE: DQ1225

Generic photo used for illustration purposes only

+RoHS Compliant

The +Suffix identifies RoHS Compliance. See our web site for RoHS Compliance methodologies and qualifications

APPLICATIONS

- Satellite up and down converters
- Defense radar & communication
- VSAT
- Line of sight links
- Federal fixed service
- 5G
- ISM

PRODUCT OVERVIEW

MDB-44H+ is an advanced wideband frequency mixer fabricated using InGaP HBT technology with integrated LO and RF Baluns. It has repeatable performance making it suitable for volume production. It is packaged in tiny 3 mm x 3 mm x 0.89 mm MCLP™ package.

KEY FEATURES

Feature	Advantages
Double Balanced	Results in excellent LO-RF (30-39 dB typical) & LO-IF (27-37 dB typical) Isolations mini-mizing need for external filtering
Wide Bandwidth, 10 to 40 GHz	Useful in wideband systems or in several narrowband systems. Reducing inventory
Wide IF Bandwidth DC-15 GHz	Usable in first and second down converter applications. IF as low as DC enables use in phase detector applications.
3 mm x 3 mm, 12 lead MCLP Package	Low Inductance, repeatable transitions, excellent thermal contact to PCB

REV. B
ECO-009182
MDB-44H+
MCL NY
210809



ELECTRICAL SPECIFICATIONS¹ AT 25°C, UNLESS NOTED

Parameter	Condition (GHz)	Min.	Typ.	Max.	Units
RF Frequency Range	-	10	-	40	GHz
LO Frequency Range	-	10	-	40	GHz
IF Frequency Range	-	DC	-	15	GHz
LO Power	-	+15			dBm
Conversion Loss (at IF=30 MHz)	10-20	-	8.0	-	dB
	20-30	-	8.4	11.0	
	30-40	-	8.9	13.4	
LO-RF Isolation	10-20	-	39	-	dB
	20-30	25	37	-	
	30-40	-	30	-	
LO-IF Isolation	10-20	-	33	-	dB
	20-30	20	37	-	
	30-40	-	27	-	
RF-IF Isolation	10-20	-	24	-	dB
	20-30	-	16	-	
	30-40	-	31	-	
Input at 1dB Compression	10-40	-	10	-	dBm
Input IP3	10-20	-	20	-	dBm
Noise Figure	20	-	8.6	-	dB
Thermal Resistance (junction-to-ground lead)		-	105	-	°C/W

1. Measured on Mini-Circuits Characterization test board TB-973-MDB44HC+. See Characterization Test Circuit Figure 1

MAXIMUM RATINGS²

Parameter	Ratings
Operating Temperature	-40°C to 85°C
Storage Temperature	-65°C to 150°C
RF Power	21 dBm
LO Power	21 dBm
IF Current	30 mA

2. Permanent damage may occur if any of these limits are exceeded. Electrical maximum ratings are not intended for continuous normal operation.



SIMPLIFIED SCHEMATIC AND BONDING PAD DESCRIPTION

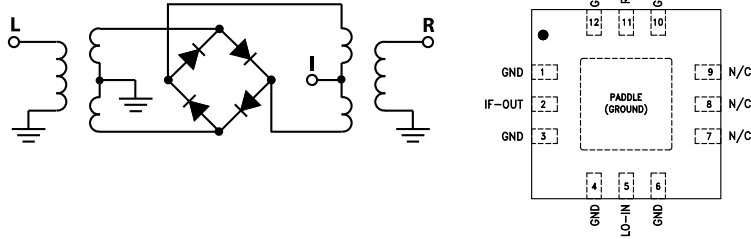

PAD CONNECTIONS

Function	Pad Number	Description
RF-IN	11	RF input
LO-IN	5	LO input
IF-OUT	2	IF output
GND	1,3,4,6,10,12, Paddle	Connect to Ground
NC	7-9	No connection, not used

CHARACTERIZATION TEST CIRCUITS

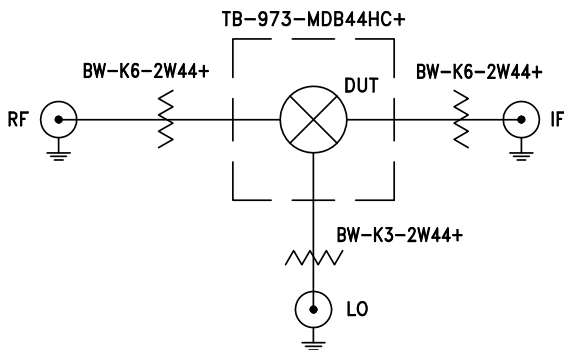

Figure 1A.
Block Diagram of Test Circuit used for characterization of Conversion Loss, Isolations (LO-RF, LO-IF, RF-IF) and Return Loss (LO, RF, IF)

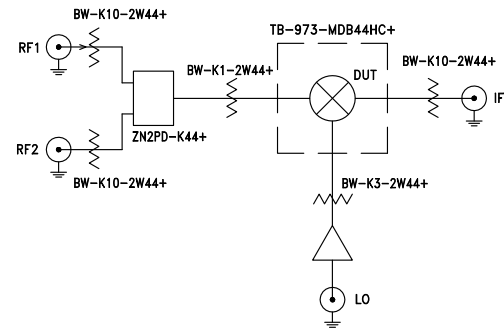

Figure 1B.
Block Diagram of Test Circuit used for characterization of Input IP3

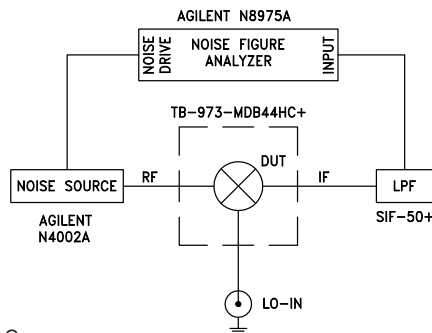

Figure 1C.
Block Diagram of Test Circuit used for characterization of Noise Figure

Figure 1. Block Diagram of Test Circuit used for characterization. (DUT soldered on Mini-Circuits Characterization test board TB-973-MDB44HC+). Conversion Loss, Isolations L-R, L-I & R-I, Input IP3 are measured using Agilent PSA E4448A spectrum Analyzer and PSG E8257D Signal Generators. NF is measured using Agilent's N8975A NF Analyzer.

Conditions (Down Converter):

1. Conversion Loss, Isolations (L-R, L-I & R-I): RF= 0 dBm, LO=+15 dBm, IF=30 MHz
2. Output IP3 (OIP3): Two tones, spaced 1 MHz apart, 0 dBm/tone at output.
3. Noise Figure: LO=+15 dBm

PRODUCT MARKING

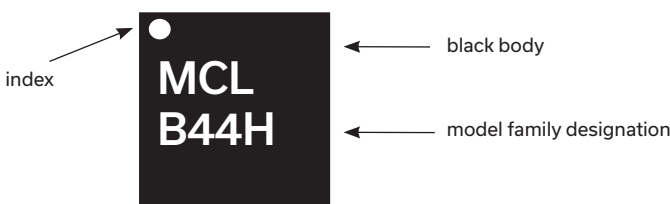

APPLICATION CIRCUIT

