

GaAs MMIC Double Balanced Mixer

MM1-0832HSM

1. Device Overview

1.1 General Description

The MM1-0832HSM is a GaAs MMIC double balanced mixer that is optimized for high frequency applications. MM1-0832HSM is a high frequency X band mixer that works well as both an up and down converter through Ka band. This mixer offers low conversion loss and high LO to RF isolations at moderate LO powers. The sister MM1-0832LSM is recommended for low power applications. The MM1-0832HSM is available in a 3x3 mm QFN package. Evaluation boards are available. For a list of recommended LO driver amps for all mixers and IQ mixers, see [here](#).

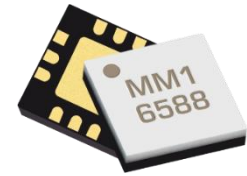

3 x 3 mm
QFN

Note: Not recommended, see [MM1-0832HPSM](#) for new design. Email [support](#) for any questions.

1.2 Features

- High IF frequency
- RoHS Compliant

1.3 Applications

- Test and measurement equipment
- Electronic Warfare
- 5G
- SATCOM

1.4 Functional Block Diagram

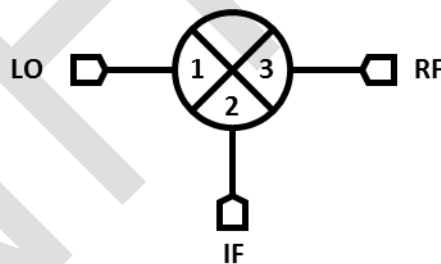

1.5 Part Ordering Options¹

| Part Number | Description | Package | Green Status | Product Lifecycle | Export Classification |
|----------------|----------------------------------|---------|--------------|-------------------|-----------------------|
| MM1-0832HSM-2 | 3x3 mm QFN | SM | RoHS | Active | EAR99 |
| EVAL-MM1-0832H | Connectorized Evaluation Fixture | Eval | | Active | EAR99 |

¹ Refer to our [website](#) for a list of definitions for terminology presented in this table.

Table of Contents

| | | | |
|--|---|---|----|
| 1. Device Overview | 1 | 3.6 Typical Performance Plots | 6 |
| 1.1 General Description | 1 | 3.6.1 Typical Performance Plots: IP3 .. | 8 |
| 1.2 Features | 1 | 3.6.2 Typical Performance Plots: LO | |
| 1.3 Applications | 1 | Harmonic Isolation..... | 9 |
| 1.4 Functional Block Diagram | 1 | 3.6.3 Typical Spurious Performance: | |
| 1.5 Part Ordering Options..... | 1 | Down-Conversion | 10 |
| 2. Port Configurations and Functions | 3 | 3.6.4 Typical Spurious Performance: | |
| 2.1 Port Diagram | 3 | Up-Conversion | 10 |
| 2.2 Port Functions | 3 | 4. Operation..... | 11 |
| 3. Specifications | 4 | 4.1 Application Circuit | 11 |
| 3.1 Absolute Maximum Ratings..... | 4 | 4.2 Ports Operation | 11 |
| 3.2 Package Information | 4 | 5. Mechanical Data..... | 12 |
| 3.3 Recommended Operating Conditions . | 4 | 5.1 SM Package Outline Drawing..... | 12 |
| 3.4 Sequencing Requirements | 4 | 5.2 SM Package Footprint | 12 |
| 3.5 Electrical Specifications | 5 | 5.3 Evaluation Board Outline Drawing... | 12 |

Revision History

| Revision Code | Revision Date | Comment |
|---------------|---------------|--|
| - | January 2019 | Datasheet Initial Release |
| A | August 2019 | Updated Low Side LO Plot Titles |
| B | October 2020 | Updated Pin 2 Description & Equivalent Circuit |



2. Port Configurations and Functions

2.1 Port Diagram

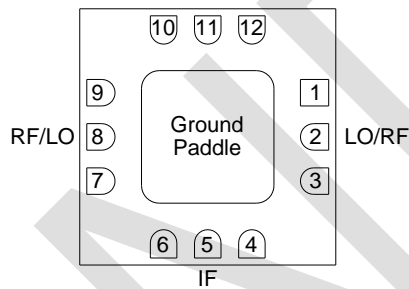
A bottom-up view of the MM1-0832HSM's SM package outline drawing is shown below. The MM1-0832HSM has the input and output ports given in Port Functions. The MM1-0832HSM can be used in either an up or down conversion. For configuration A, input the LO into pin 2, use pin 8 for the RF, and pin 5 for the IF. For configuration B, input the LO into pin 8, use pin 2 for the RF, and pin 5 for the IF.

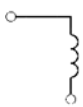
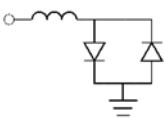
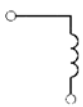

2.2 Port Functions

| Port | Function | Description | Equivalent Circuit for Package |
|-------|--|--|--|
| Pin 2 | LO (Configuration A) RF (Configuration B) | Pin 2 is DC open and AC matched to 50 Ohms from 8 to 32 GHz. |  |
| Pin 5 | IF | Pin 5 is DC coupled to the diodes. Blocking capacitor is optional. |  |
| Pin 8 | RF (Configuration A) LO (Configuration B) | Pin 8 is DC open and AC matched to 50 Ohms from 8 to 32 GHz. |  |
| GND | Ground | SM package ground path is provided through the ground paddle. | GND  |

3. Specifications

3.1 Absolute Maximum Ratings

The Absolute Maximum Ratings indicate limits beyond which damage may occur to the device. If these limits are exceeded, the device may be inoperable or have a reduced lifetime.

| Parameter | Maximum Rating | Units |
|-----------------------------|----------------|-------|
| Pin 2 DC Current | 30 | mA |
| Pin 5 DC Current | 15 | mA |
| Power Handling, at any Port | +28 | dBm |
| Operating Temperature | -55 to +100 | °C |
| Storage Temperature | -65 to +125 | °C |

3.2 Package Information

| Parameter | Details | Rating |
|-----------|--|--------|
| ESD | Human Body Model (HBM), per MIL-STD-750, Method 1020 | 1A |
| Weight | EVAL package | 13.4 g |

3.3 Recommended Operating Conditions

The Recommended Operating Conditions indicate the limits, inside which the device should be operated, to guarantee the performance given in Electrical Specifications. Operating outside these limits may not necessarily cause damage to the device, but the performance may degrade outside the limits of the electrical specifications. For limits, above which damage may occur, see Absolute Maximum Ratings.

| | Min | Nominal | Max | Units |
|--------------------------------------|-----|---------|------|-------|
| T _A , Ambient Temperature | -55 | +25 | +100 | °C |
| LO Input Power | +16 | | +23 | dBm |

3.4 Sequencing Requirements

There is no requirement to apply power to the ports in a specific order. However, it is recommended to provide a 50Ω termination to each port before applying power. This is a passive diode mixer that requires no DC bias.

3.5 Electrical Specifications

The electrical specifications apply at $T_A = +25^\circ\text{C}$ in a 50Ω system. Typical data shown is for a down conversion application with a +18dBm sine wave LO input. Specifications shown for configuration A (B).

| Parameter | | Test Conditions | Min | Typical | Max | Units |
|--|----------|--|-----|----------------|--------------|-------|
| RF (Pin 8) Frequency Range | | | 8 | | 32 | GHz |
| LO (Pin 2) Frequency Range | | | 8 | | 30 | |
| I (Pin 5) Frequency Range | | | 0 | | 12 | |
| Conversion Loss (CL) ² | | RF/LO = 8 - 30 GHz I = DC - 0.2 GHz | | 7 (8.5) | 10.5 (12) | dB |
| | | RF/LO = 8 - 30 GHz I = 0.2 - 12 GHz | | 8 (9.5) | | |
| Noise Figure (NF) ³ | | RF/LO = 8 - 30 GHz I = DC - 0.2 GHz | | 8.5 | | dB |
| Isolation | LO to RF | RF/LO = 8 - 32 GHz | | 36 | | dB |
| | LO to IF | IF/LO = 8 - 32 GHz | | 23 | | |
| | RF to IF | RF/IF = 8 - 32 GHz | | 23 | | |
| Input IP3 (IIP3) | | RF/LO = 8 - 32 GHz I = DC - 0.2 GHz | | +20.5 (+22) | | dBm |
| Input 1 dB Gain Compression Point (P1dB) | | | | +9 (+11) | | dBm |

² Measured as a down converter to a fixed 91MHz IF.

³ Mixer Noise Figure typically measures within 0.5 dB of conversion loss for IF frequencies greater than 5 MHz.

3.6 Typical Performance Plots

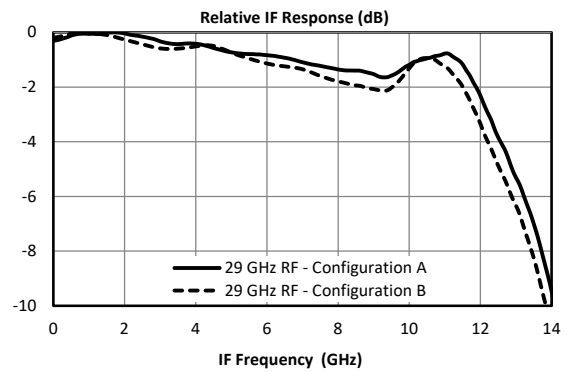
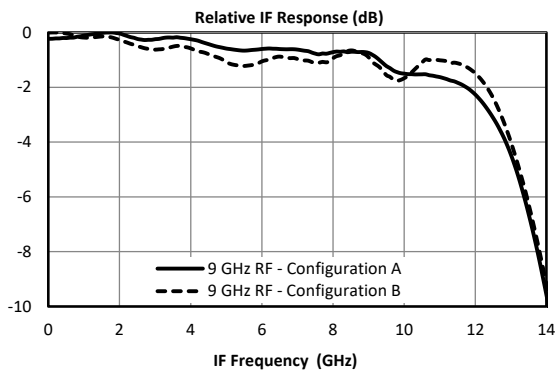
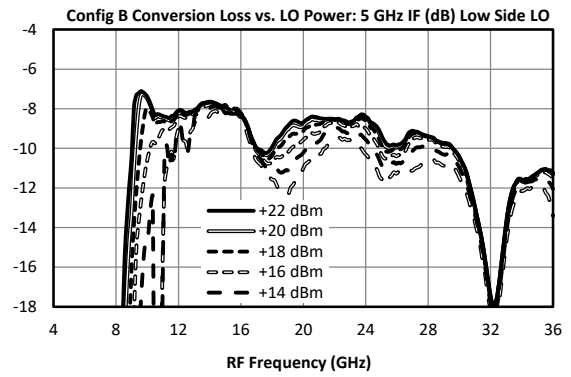
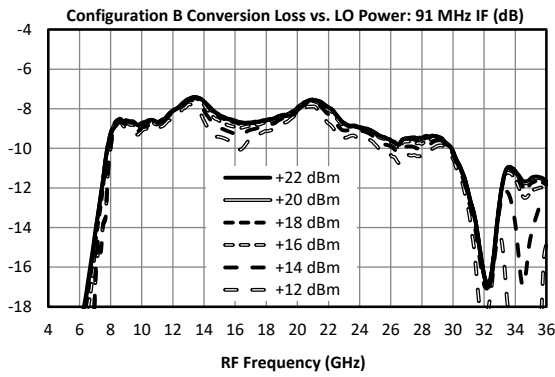
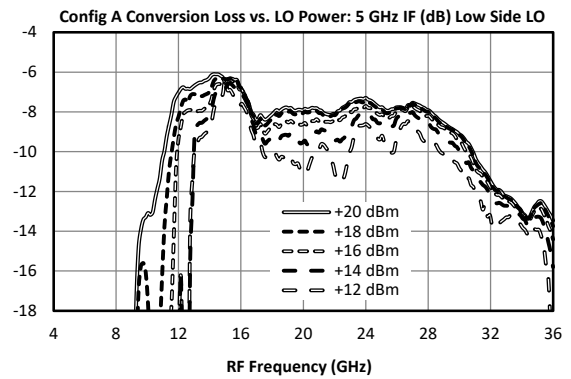
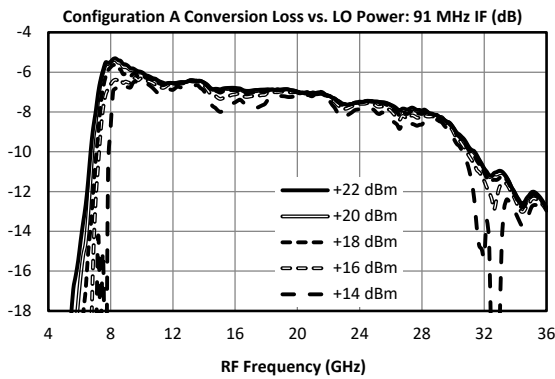
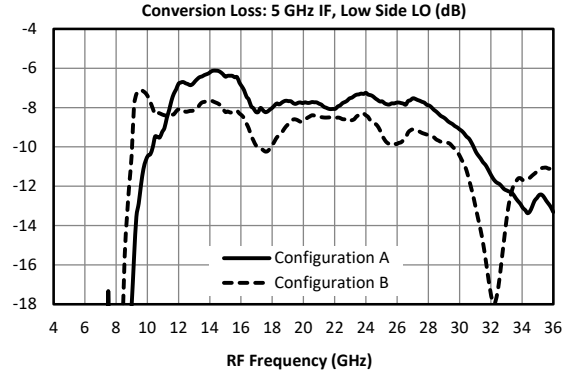
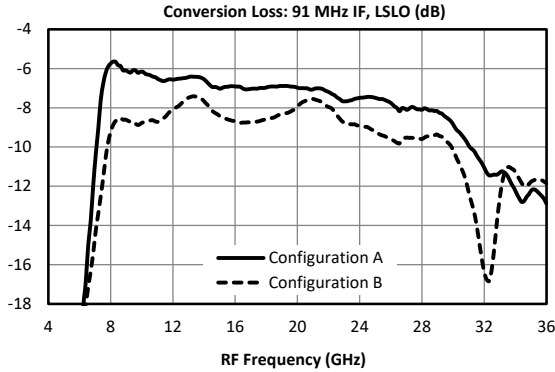

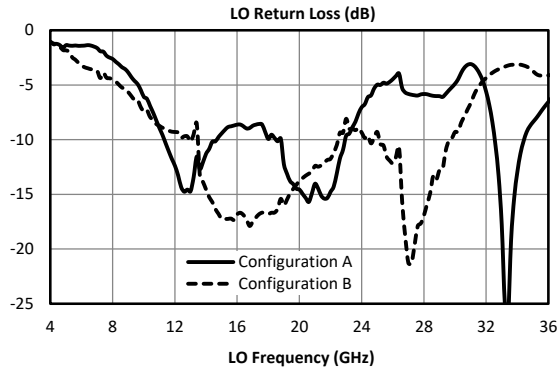
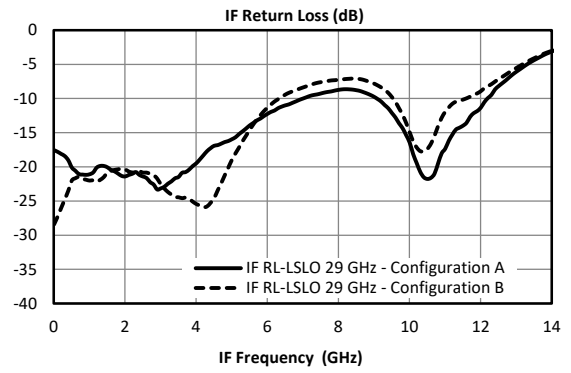
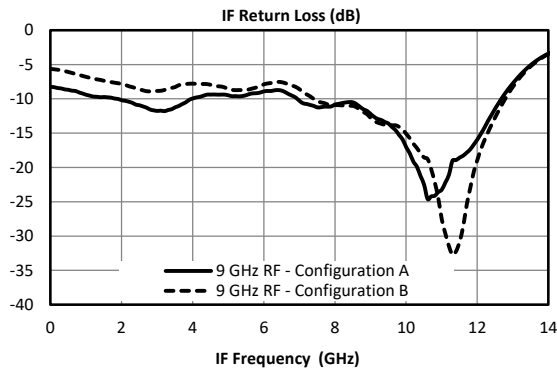
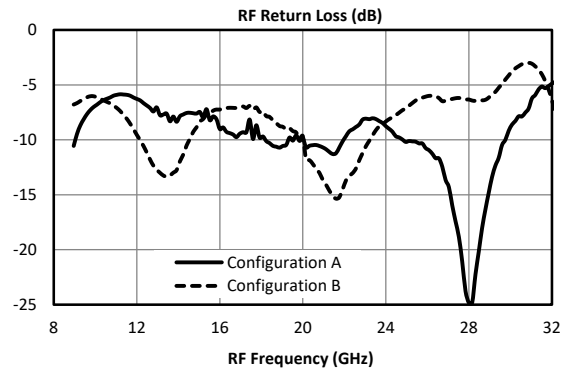
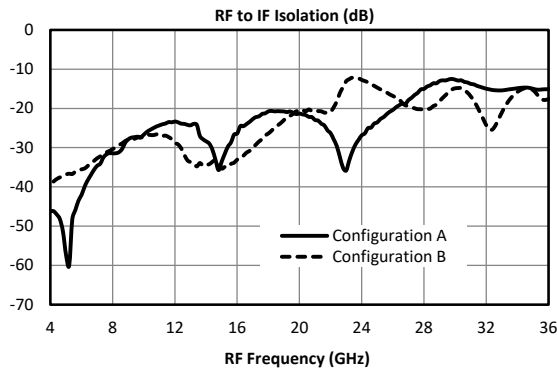
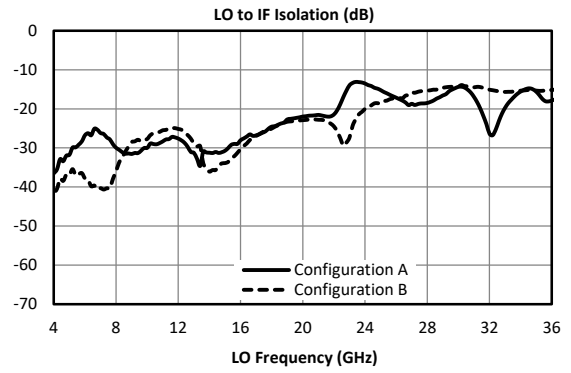
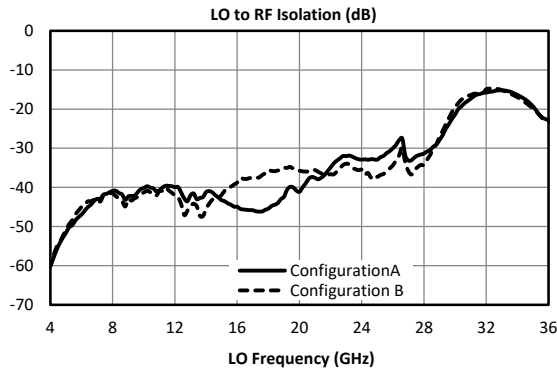

3.6.1 Typical Performance Plots: IP3

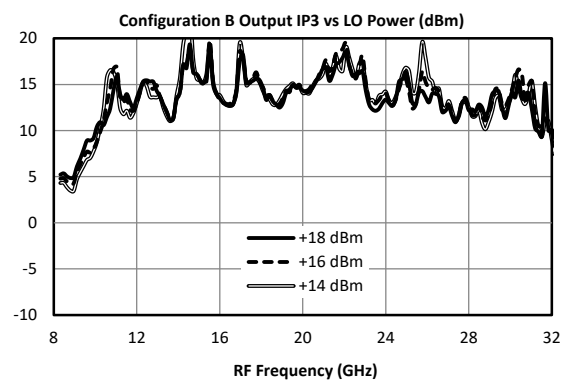
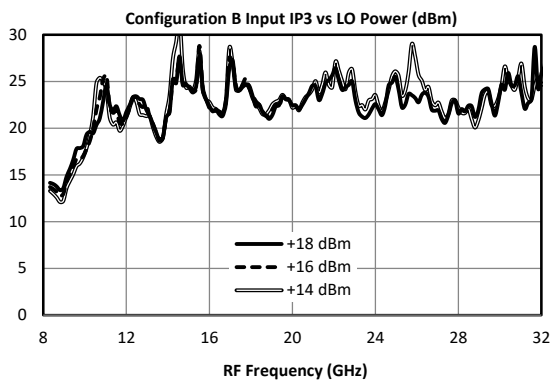
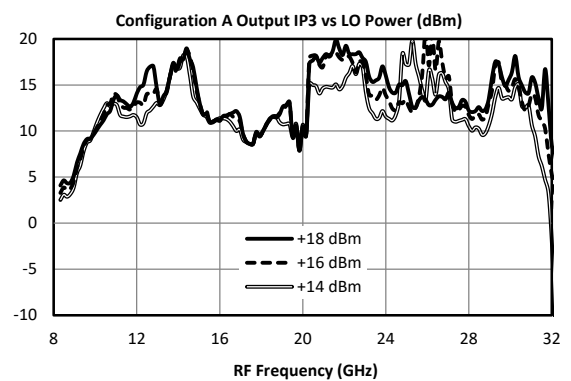
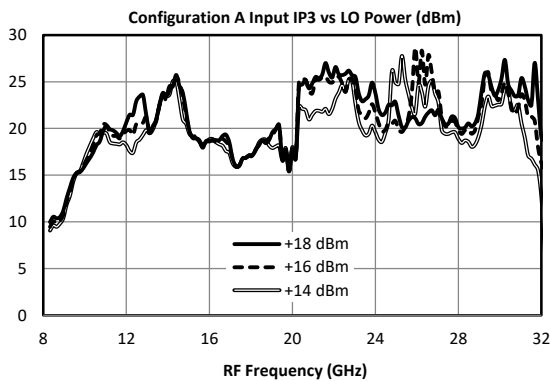
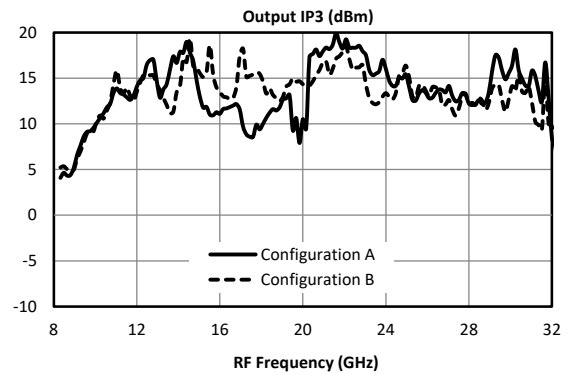
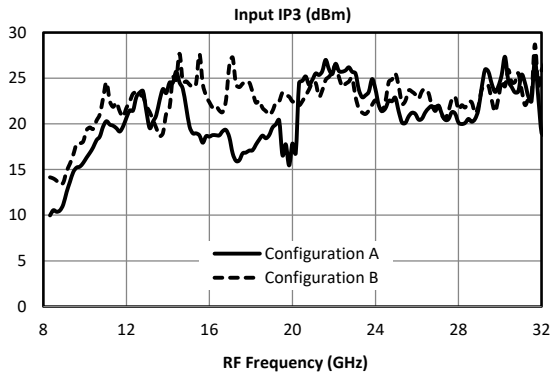

3.6.2 Typical Performance Plots: LO Harmonic Isolation

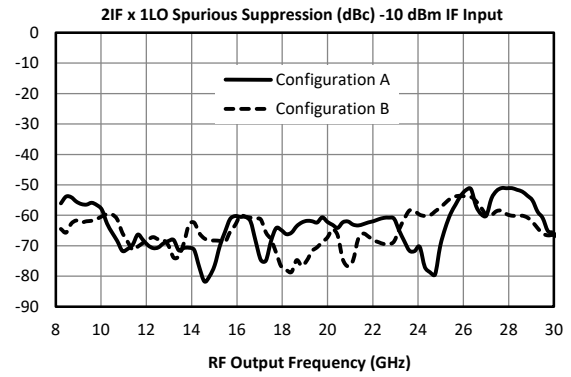
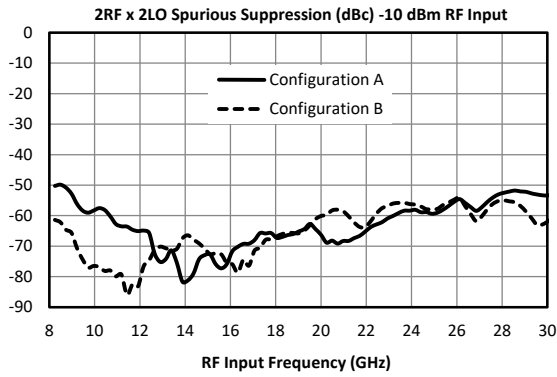
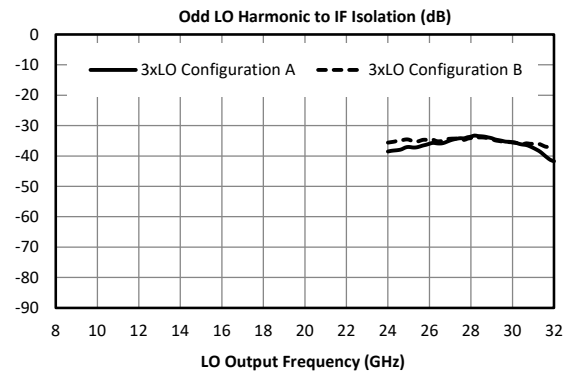
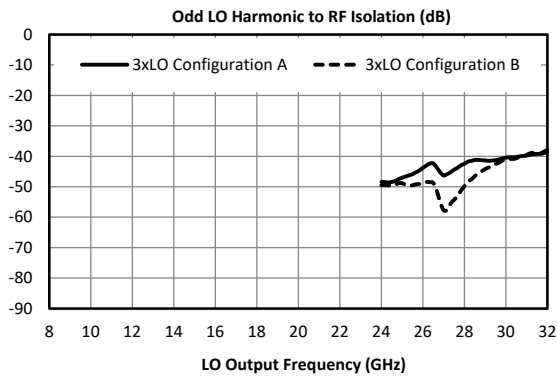
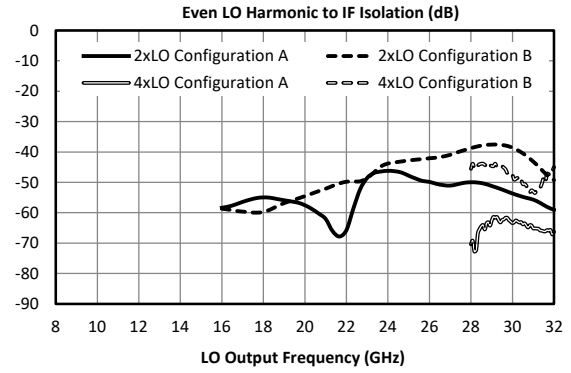
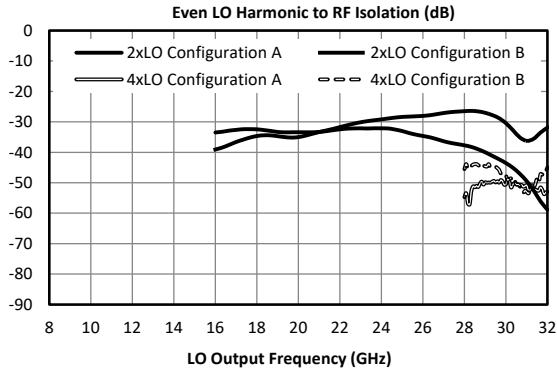

3.6.3 Typical Spurious Performance: Down-Conversion

Typical spurious data is provided by selecting RF and LO frequencies ($\pm m \cdot \text{LO} \pm n \cdot \text{RF}$) within the RF/LO bands, to create a spurious output within the IF band. The mixer is swept across the full spurious band and the mean is calculated. The numbers shown in the table below are for a -10 dBm RF input. Spurious suppression is scaled for different RF power levels by $(n-1)$, where "n" is the RF spur order. For example, the 2RF x 2LO spur is 61 dBc for a -10 dBm input, so a -20 dBm RF input creates a spur that is $(2-1) \times (-10 \text{ dB})$ lower, or 71 dBc. Data is shown for the frequency plan in 3.6 Typical Performance.

Typical Down-conversion spurious suppression (dBc): Config A (B)

| -10 dBm RF Input | 0xLO | 1xLO | 2xLO | 3xLO | 4xLO | 5xLO |
|------------------|-----------|-----------|-----------|-----------|-----------|-----------|
| 1xRF | 17 (11) | Reference | 29 (36) | 13 (15) | 78 (54) | 81 (73) |
| 2xRF | 72 (71) | 59 (49) | 61 (64) | 60 (53) | 64 (67) | 56 (54) |
| 3xRF | 74 (78) | 59 (63) | 79 (86) | 71 (75) | 78 (86) | 66 (75) |
| 4xRF | 108 (103) | 91 (89) | 105 (108) | 107 (106) | 107 (109) | 107 (104) |
| 5xRF | 118 (120) | 108 (95) | 112 (120) | 119 (121) | 119 (123) | 117 (123) |

3.6.4 Typical Spurious Performance: Up-Conversion

Typical spurious data is taken by mixing an input within the IF band, with LO frequencies ($\pm m \cdot \text{LO} \pm n \cdot \text{IF}$), to create a spurious output within the RF output band. The mixer is swept across the full spurious output band and the mean is calculated. The numbers shown in the table below are for a -10 dBm IF input. Spurious suppression is scaled for different IF input power levels by $(n-1)$, where "n" is the IF spur order. For example, the 2IFx1LO spur is typically 63 dBc for a -10 dBm input with a sine-wave LO, so a -20 dBm IF input creates a spur that is $(2-1) \times (-10 \text{ dB})$ lower, or 73 dBc. Data is shown for the frequency plan in 3.6 Typical Performance.

Typical Up-conversion spurious suppression (dBc): Config A (B)

| -10 dBm RF Input | 0xLO | 1xLO | 2xLO | 3xLO | 4xLO | 5xLO |
|------------------|-----------|-----------|-----------|-----------|-----------|-----------|
| 1xIF | 23 (22) | Reference | 32 (39) | 14 (14) | 34 (39) | 25 (36) |
| 2xIF | 80 (59) | 63 (64) | 56 (46) | 57 (66) | 49 (64) | 57 (58) |
| 3xIF | 97 (102) | 67 (70) | 75 (86) | 67 (67) | 74 (83) | 55 (61) |
| 4xIF | 117 (113) | 106 (112) | 95 (88) | 100 (105) | 87 (91) | 98 (107) |
| 5xIF | 131 (132) | 112 (114) | 116 (121) | 104 (97) | 121 (125) | 101 (104) |

4. Operation

4.1 Application Circuit

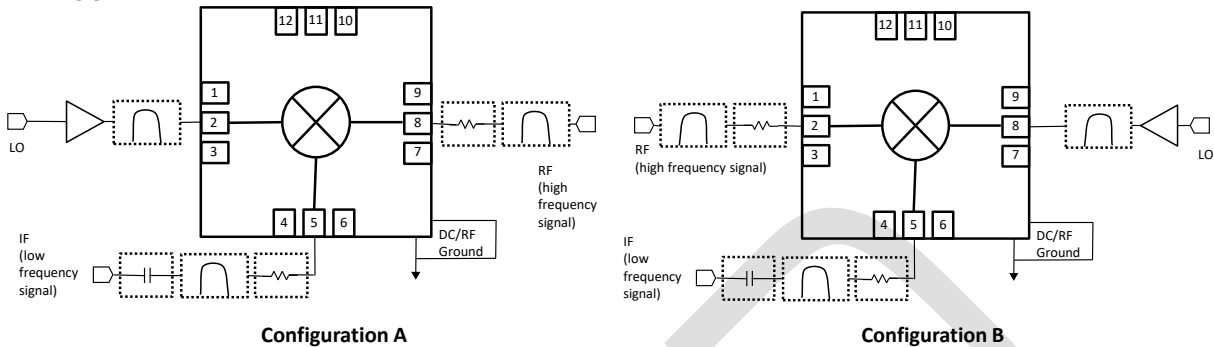

4.2 Ports Operation

IF Port – Used as input on an upconversion, output on downconversion, or LO port in a band shifting application. Signals should be connected by 50 ohm microstrip or coplanar traces to well matched broadband 50 ohm sources and loads. Blocking capacitor is recommended if DC voltage is present on the line.

RF Port – Used as input on a downconversion, output on upconversion, or output in a band shifting application. Signals should be connected by 50 ohm microstrip or coplanar traces to well matched broadband 50 ohm sources and loads.

Filtering and Matching- Filtering is generally desired for spurious and image removal on the output port of the mixer. Reflective filters can cause out of band signals to reflect back into the mixer and cause conversion loss ripple, erroneous spurs, and other undesired behaviors. To eliminate these problems it is recommended that the filters be placed as close to the output port as possible. If undesired behavior is still observed, a diplexer with one port terminated or a 1-3 dB attenuator may reduce this problem.

RF Ground – The ground paddle of the QFN should be connected to a low noise RF ground with very low electrical resistance for high frequency operation.

LO Port – The noise floor of the LO input signal should be less than the value of the noise floor plus isolation of the mixer, or a filter is recommended to prevent reduction in dynamic range. An LO amplifier is required if the LO power is below the recommended drive level. It is important to use an amplifier with a broadband 50 ohm match such that it does not reflect spurious signals back into the mixer or other system circuitry.

5. Mechanical Data

5.1 SM Package Outline Drawing

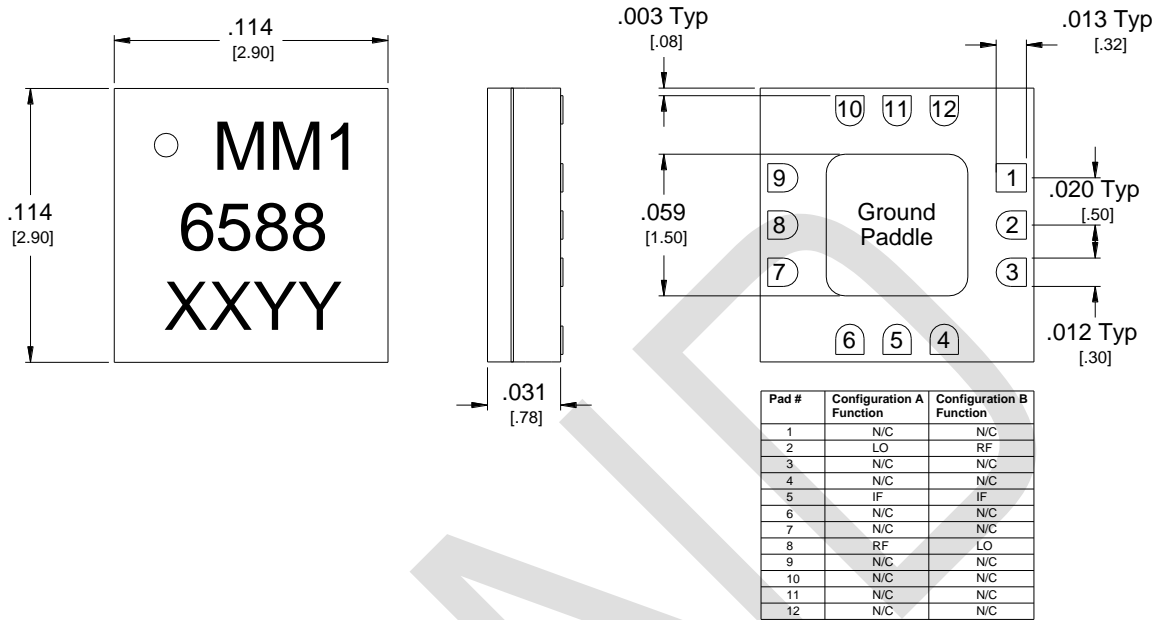

- Substrate material is ceramic.
- I/O Leads and Ground Paddle plating is (from base to finish):

| | | |
|-----|-------------|------------|
| Ni: | 8.89um MAX | 1.27um MIN |
| Pd: | 0.17um MAX | 0.07um MIN |
| Au | 0.254um MAX | 0.03um MIN |
- All unconnected pads should be connected to PCB RF ground.

5.2 SM Package Footprint

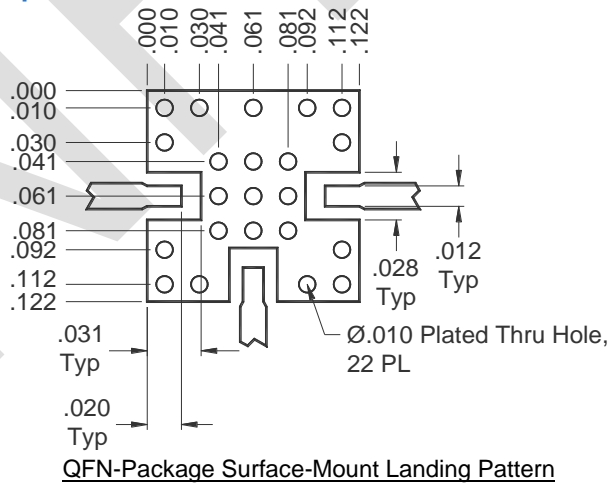

[Click here for a DXF of the above layout.](#)

[Click here for leaded solder reflow.](#) [Click here for lead-free solder reflow.](#)