

Description

The [XR33052](#), [XR33053](#), [XR33055](#), and [XR33058](#) (XR3305x) are a family of high performance RS-485/RS-422 devices designed for improved performance in noisy industrial environments and increased tolerance to system faults.

The analog bus pins can withstand direct shorts up to ±60V and are protected against ESD events up to ±15kV HBM. An extended ±25V common mode operating range allows for more reliable operation in noisy environments.

The XR3305x receivers include full fail-safe circuitry, guaranteeing a logic-high receiver output when the receiver inputs are open, shorted or undriven. The XR33052/53/55 receiver input impedance is at least 120kΩ (1/10 unit load), allowing more than 320 devices on the bus. The XR33058 receiver input impedance is at least 30KΩ (1/2.5 unit load), allowing more than 80 devices on the bus.

The driver is protected by short circuit detection as well as thermal shutdown and maintains high impedance in shutdown or when powered off.

The DE and \overline{RE} pins include hot swap circuitry to prevent false transitions on the bus during power up or live insertion and can enter a 1nA low current shutdown mode for extreme power savings.

The XR33052/55/58 are half-duplex transceivers offered in an 8-pin NSOIC package and operates at a maximum data rates of 250k, 1M and 20Mbps. The XR33053 is a full-duplex transceiver offered in a 14-pin NSOIC package and operates at a maximum data rate of 1 Mbps.

FEATURES

- 3.0V to 5.5V operation
- ±60V fault tolerance on analog bus pins
- Extended ±25V common mode operation
- Robust ESD protection:
 - ±15kV HBM (bus pins)
 - ±4kV HBM (non-bus pins)
- Enhanced receiver fail-safe protection for open, shorted or terminated but idle data lines
- Hot swap glitch protection on DE and \overline{RE} pins
- Driver short circuit current limit and thermal shutdown for overload protection
- Reduced unit loads allows up to 320 devices on bus
- Industry standard 8-pin and 14-pin NSOIC packages
- -40°C to 85°C and -40°C to 105°C ambient operating temperature ranges

APPLICATIONS

- Industrial control networks
- HVAC networks
- Building and process automation
- Remote utility meter reading
- Energy monitoring and control
- Long or unterminated transmission lines

Ordering Information - [Page 19](#)

Typical Application

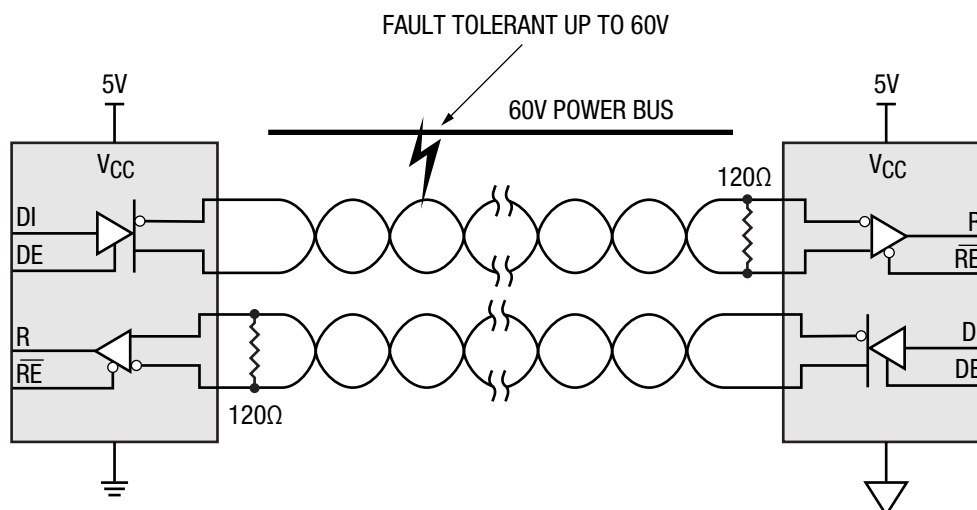

Figure 1. Typical Application

Absolute Maximum Ratings

Stresses beyond the limits listed below may cause permanent damage to the device. Exposure to any Absolute Maximum Rating condition for extended periods may affect device reliability and lifetime.

| | |
|---|------------------------------|
| V_{CC} | -0.3V to 7.0V |
| Input voltage (DE and DI) | -0.3V to 7.0V |
| Input voltage (\overline{RE})..... | -0.3V to ($V_{CC} + 0.3V$) |
| Receiver output voltage (RO)..... | -0.3V to ($V_{CC} + 0.3V$) |
| Driver output voltage (Y, Z, A/Y and B/Z)..... | $\pm 60V$ |
| Receiver input voltage (A, B, A/Y and B/Z) | $\pm 60V$ |
| Transient voltage pulse, through 100 Ω | $\pm 100V$ |
| Driver output current..... | $\pm 250mA$ |
| Maximum junction temperature | 150°C |
| Storage temperature | -65°C to 150°C |
| Lead temperature (soldering 10 seconds)..... | 300°C |

ESD Ratings

| | |
|---|------------|
| HBM - Human Body Model (A, B, Y and Z pins) | $\pm 15kV$ |
| HBM - Human Body Model (all other pins) | $\pm 4kV$ |

Operating Conditions

| | |
|---|----------------|
| Supply voltage range..... | 3.0V to 5.5V |
| Operating temperature range | -40°C to 105°C |
| Package power dissipation, 8-pin NSOIC θ_{JA} | 128.4°C/W |
| Package power dissipation, 14-pin NSOIC θ_{JA} | 86°C/W |

Electrical Characteristics

Unless otherwise noted: $V_{CC} = 3.0V$ to $5.5V$, $T_A = T_{MIN}$ to T_{MAX} . Typical values are at $V_{CC} = 5.0V$, $T_A = 25^\circ C$.

| Symbol | Parameter | Conditions | Min | Typ | Max | Units |
|---------------------------|---|--|------|-----|-----------|---------|
| Driver DC Characteristics | | | | | | |
| V_{CC} | Supply voltage range | | 3.0 | | 5.5 | V |
| V_{OD} | Differential driver output, $4.5V \leq V_{CC} \leq 5.5V$ | $R_L = 100\Omega$ (RS-422), Figure 3 | 2 | | V_{CC} | V |
| | | $R_L = 54\Omega$ (RS-485), Figure 3 | 1.5 | | V_{CC} | V |
| | | $-25V \leq V_{CM} \leq 25V$, Figure 4 | 1.5 | | V_{CC} | V |
| | Differential driver output, $3.0V \leq V_{CC} \leq 4.5V$ | $R_L = 100\Omega$ (RS-422), Figure 3 | 0.85 | | V_{CC} | V |
| | | $R_L = 54\Omega$ (RS-485), Figure 3 | 0.65 | | V_{CC} | V |
| ΔV_{OD} | Change in magnitude of differential output voltage ⁽¹⁾ | | | | ± 0.2 | V |
| V_{CM} | Driver common-mode output voltage (steady state) | $R_L = 100\Omega$ (RS-422) or $R_L = 54\Omega$ (RS-485), Figure 3 | 1 | | 3 | V |
| ΔV_{CM} | Change in magnitude of common-mode output voltage ⁽¹⁾ | | | | ± 0.2 | V |
| V_{IH} | Logic high input thresholds (DI, DE and \overline{RE}) | $V_{CC} = 3.3V$ | 2.0 | | | V |
| | | $V_{CC} = 5.0V$ | 2.4 | | | V |
| V_{IL} | Logic low input thresholds (DI, DE and \overline{RE}) | | | | 0.8 | V |
| V_{HYS} | Input hysteresis (DI, DE and \overline{RE}) | | | 100 | | mV |
| I_{IN} | Logic input current (DI, DE and \overline{RE}) | $0V \leq V_{IN} \leq V_{CC}$, After first transition ⁽²⁾ | | | ± 1 | μA |
| I_{INHS} | Logic input current hot swap (DE and \overline{RE}) | Until first transition ⁽²⁾ | | 100 | ± 200 | μA |
| $I_{A, B}$ | Input current (A and B) | $V_{CC} = 0V$ or $5.5V$, $V_{OUT} = 12V$, $DE = 0V$, for XR33052/53/55 | | | 100 | μA |
| | | $V_{CC} = 0V$ or $5.5V$, $V_{OUT} = -7V$, $DE = 0V$, for XR33052/53/55 | -80 | | | μA |
| | | $V_{OUT} = 12V$, $DE = 0V$, $V_{CC} = 0V$ or $5.5V$, for XR33058 | | | 400 | μA |
| | | $V_{OUT} = -7V$, $DE = 0V$, $V_{CC} = 0V$ or $5.5V$, for XR33058 | -320 | | | μA |
| I_{OL} | Output leakage (Y and Z) full-duplex | $V_{OUT} = 12V$, $DE = 0V$, $V_{CC} = 0V$ or $5.5V$ | | | 100 | μA |
| | | $V_{OUT} = -7V$, $DE = 0V$, $V_{CC} = 0V$ or $5.5V$ | -80 | | | μA |
| I_{OSD} | Driver short-circuit output current | $-60V \leq V_{OUT} \leq 60V$, $DI = 0V$ or V_{CC} , Figure 5 | | | ± 250 | mA |

NOTES:

- Change in magnitude of differential output voltage and change in magnitude of common mode output voltage are the changes in output voltage when DI input changes state.
- The hot swap feature disables the DE and \overline{RE} inputs for the first 10 μs after power is applied. Following this time period, these inputs are weakly pulled to their disabled state (low for DE, high for \overline{RE}) until the first transition, after which they become high impedance inputs.

Electrical Characteristics (Continued)

Unless otherwise noted: $V_{CC} = 3.0V$ to $5.5V$, $T_A = T_{MIN}$ to T_{MAX} . Typical values are at $V_{CC} = 5.0V$, $T_A = 25^\circ C$.

| Symbol | Parameter | Conditions | Min | Typ | Max | Units |
|---------------------------------------|--|---|----------------|----------|-----------|------------|
| Driver Thermal Characteristics | | | | | | |
| T_{TS} | Thermal shutdown temperature | Junction temperature ⁽¹⁾ | | 175 | | $^\circ C$ |
| T_{TSH} | Thermal shutdown hysteresis ⁽¹⁾ | | | 15 | | $^\circ C$ |
| Receiver DC Characteristics | | | | | | |
| V_{STH} | Receiver differential input signal threshold voltage ($V_A - V_B$) | $-25V \leq V_{OUT} \leq 25V$ | | ± 85 | ± 200 | mV |
| ΔV_{STH} | Receiver differential input signal hysteresis | | | 170 | | mV |
| V_{FSTH-} | Negative going receiver differential input fail-safe threshold voltage ($V_A - V_B$) | $-25V \leq V_{OUT} \leq 25V$ | -200 | -125 | -40 | mV |
| V_{FSTH+} | Positive going receiver differential input fail-safe threshold voltage ($V_A - V_B$) | $-25V \leq V_{OUT} \leq 25V$ | | -100 | -10 | mV |
| ΔV_{FSTH} | Receiver differential input fail-safe hysteresis | | | 25 | | mV |
| V_{OH} | Receiver output high voltage (RO) | $I_{OUT} = -4mA$ | $V_{CC} - 0.6$ | | | V |
| V_{OL} | Receiver output low voltage (RO) | $I_{OUT} = 4mA$ | | | 0.4 | V |
| I_{OZR} | High-Z receiver output current | $0V \leq V_{OUT} \leq V_{CC}$ | | | ± 1 | μA |
| R_{IN} | RX input resistance | $-25V \leq V_{CM} \leq 25V$, XR33052/53/55 | 120 | | | $k\Omega$ |
| | | $-25V \leq V_{CM} \leq 25V$, XR33058 | 30 | | | $k\Omega$ |
| I_{OSC} | RX output short-circuit current | $0V \leq V_{RO} \leq V_{CC}$ | | | 110 | mA |
| Supply Current | | | | | | |
| I_{CC} | Supply current | No load, $\overline{RE} = 0V$ or V_{CC} , $DE = V_{CC}$, $DI = 0V$ or V_{CC} | | | 4 | mA |
| I_{SHDN} | Supply current in shutdown mode | $\overline{RE} = V_{CC}$, $DE = 0V$ | | 0.001 | 1 | μA |

NOTE:

1. This spec is guaranteed by design and bench characterization.

Electrical Characteristics (Continued)

Driver AC Characteristics - XR33052 (250kbps)

Unless otherwise noted: $V_{CC} = 3.0V$ to $5.5V$, $T_A = T_{MIN}$ to T_{MAX} . Typical values are at $V_{CC} = 5.0V$, $T_A = 25^\circ C$.

| Symbol | Parameter | Conditions | Min | Typ | Max | Units |
|-------------------------|--|---|-----|-----|------|-------|
| t_{DPLH} | Driver propagation delay (low to high) | $C_L = 50pF$, $R_L = 54\Omega$, Figure 7 | 350 | | 1500 | ns |
| t_{DPHL} | Driver propagation delay (high to low) | | 350 | | 1600 | ns |
| $ t_{DPLH} - t_{DPHL} $ | Differential driver output skew | | | 20 | 200 | ns |
| t_{DR} , t_{DF} | Driver differential output rise or fall time | | | 400 | | 1500 |
| | Maximum data rate | $1/t_{UI}$, duty cycle 40% to 60% | 250 | | | kbps |
| t_{DZH} | Driver enable to output high | $C_L = 50pF$, $R_L = 500\Omega$, Figure 8 | | 200 | 2500 | ns |
| t_{DZL} | Driver enable to output low | | | 200 | 2500 | ns |
| t_{DHZ} | Driver disable from output high | | | | 250 | ns |
| t_{DLZ} | Driver disable from output low | | | | 250 | ns |
| $t_{RZH}(SHDN)$ | Driver enable from shutdown to output high | $C_L = 50pF$, $R_L = 500\Omega$, Figure 8 | | | 5500 | ns |
| $t_{RZL}(SHDN)$ | Driver enable from shutdown to output low | | | | 5500 | ns |
| t_{SHDN} | Time to shutdown | Notes 1 and 2 | 50 | 200 | 600 | ns |

Receiver AC Characteristics -XR33052 (250kbps)

Unless otherwise noted: $V_{CC} = 3.0V$ to $5.5V$, $T_A = T_{MIN}$ to T_{MAX} . Typical values are at $V_{CC} = 5.0V$, $T_A = 25^\circ C$.

| Symbol | Parameter | Conditions | Min | Typ | Max | Units |
|-------------------------|--|---|-----|-----|------|-------|
| t_{RPLH} | Receiver propagation delay (low to high) | $C_L = 15pF$, $V_{ID} = \pm 2V$, V_{ID} rise and fall times $< 15ns$, Figure 9 | | | 200 | ns |
| t_{RPHL} | Receiver propagation delay (high to low) | | | | 200 | ns |
| $ t_{RPLH} - t_{RPHL} $ | Receiver propagation delay skew | | | | 30 | ns |
| | Maximum data rate | $1/t_{UI}$, duty cycle 40% to 60% | 250 | | | kbps |
| t_{RZH} | Receiver enable to output high | $C_L = 15pF$, $R_L = 1k\Omega$, Figure 10 | | | 50 | ns |
| t_{RZL} | Receiver enable to output low | | | | 50 | ns |
| t_{RHZ} | Receiver disable from output high | | | | 50 | ns |
| t_{RLZ} | Receiver disable from output low | | | | 50 | ns |
| $t_{RZH}(SHDN)$ | Receiver enable from shutdown to output high | $C_L = 15pF$, $R_L = 1k\Omega$, Figure 10 | | | 3500 | ns |
| $t_{RZL}(SHDN)$ | Receiver enable from shutdown to output low | | | | 3500 | ns |
| t_{SHDN} | Time to shutdown | Notes 1 and 2 | 50 | 200 | 600 | ns |

NOTES:

- The transceivers are put into shutdown by bringing \overline{RE} high and DE low simultaneously for at least 600ns. If the control inputs are in this state for less than 50ns, the device is guaranteed to not enter shutdown. If the enable inputs are held in this state for at least 600ns, the device is ensured to be in shutdown. Note that the receiver and driver enable times increase significantly when coming out of shutdown.
- This spec is guaranteed by design and bench characterization.

Electrical Characteristics (Continued)

Driver AC Characteristics - XR33053 and XR33055 (1Mbps)

Unless otherwise noted: $V_{CC} = 3.0V$ to $5.5V$, $T_A = T_{MIN}$ to T_{MAX} . Typical values are at $V_{CC} = 5.0V$, $T_A = 25^\circ C$.

| Symbol | Parameter | Conditions | Min | Typ | Max | Units | |
|-------------------------|--|---|-----|------|------|-------|----|
| t_{DPLH} | Driver propagation delay (low to high) | $C_L = 50pF$, $R_L = 54\Omega$, Figure 7 | | 150 | 500 | ns | |
| t_{DPHL} | Driver propagation delay (high to low) | | | 150 | 500 | ns | |
| $ t_{DPLH} - t_{DPHL} $ | Differential driver output skew | | | | 5 | 50 | ns |
| t_{DR} , t_{DF} | Driver differential output rise or fall time | | | 100 | 200 | 300 | ns |
| | Maximum data rate | $1/t_{UI}$, duty cycle 40% to 60% | 1 | | | Mbps | |
| t_{DZH} | Driver enable to output high | $C_L = 50pF$, $R_L = 500\Omega$, Figure 8 | | 1000 | 2500 | ns | |
| t_{DZL} | Driver enable to output low | | | 1000 | 2500 | ns | |
| t_{DZH} | Driver disable from output high | | | | 250 | ns | |
| t_{DLZ} | Driver disable from output low | | | | 250 | ns | |
| $t_{DZH(SHDN)}$ | Driver enable from shutdown to output high | $C_L = 50pF$, $R_L = 500\Omega$, Figure 8 | | 2500 | 4500 | ns | |
| $t_{DZL(SHDN)}$ | Driver enable from shutdown to output low | | | 2500 | 4500 | ns | |
| t_{SHDN} | Time to shutdown | Notes 1 and 2 | 50 | 200 | 600 | ns | |

Receiver AC Characteristics - XR33053 and XR33055 (1Mbps)

Unless otherwise noted: $V_{CC} = 3.0V$ to $5.5V$, $T_A = T_{MIN}$ to T_{MAX} . Typical values are at $V_{CC} = 5.0V$, $T_A = 25^\circ C$.

| Symbol | Parameter | Conditions | Min | Typ | Max | Units |
|-------------------------|--|---|-----|-----|------|-------|
| t_{RPLH} | Receiver propagation delay (low to high) | $C_L = 15pF$, $V_{ID} = \pm 2V$, V_{ID} rise and fall times $< 15ns$, Figure 9 | | | 200 | ns |
| t_{RPHL} | Receiver propagation delay (high to low) | | | | 200 | ns |
| $ t_{RPLH} - t_{RPHL} $ | Receiver propagation delay skew | | | | 30 | ns |
| | Maximum data rate | $1/t_{UI}$, duty cycle 40% to 60% | 1 | | | Mbps |
| t_{RZH} | Receiver enable to output high | $C_L = 15pF$, $R_L = 1k\Omega$, Figure 10 | | | 50 | ns |
| t_{RZL} | Receiver enable to output low | | | | 50 | ns |
| t_{RHZ} | Receiver disable from output high | | | | 50 | ns |
| t_{RLZ} | Receiver disable from output low | | | | 50 | ns |
| $t_{RZH(SHDN)}$ | Receiver enable from shutdown to output high | $C_L = 15pF$, $R_L = 1k\Omega$, Figure 10 | | | 3500 | ns |
| $t_{RZL(SHDN)}$ | Receiver enable from shutdown to output low | | | | 3500 | ns |
| t_{SHDN} | Time to shutdown | Notes 1 and 2 | 50 | 200 | 600 | ns |

NOTES:

1. The transceivers are put into shutdown by bringing \overline{RE} high and DE low simultaneously for at least 600ns. If the control inputs are in this state for less than 50ns, the device is guaranteed to not enter shutdown. If the enable inputs are held in this state for at least 600ns, the device is ensured to be in shutdown. Note that the receiver and driver enable times increase significantly when coming out of shutdown.
2. This spec is guaranteed by design and bench characterization.

Electrical Characteristics (Continued)

Driver AC Characteristics - XR33058 (20Mbps)

Unless otherwise noted: $V_{CC} = 3.0V$ to $5.5V$, $T_A = T_{MIN}$ to T_{MAX} . Typical values are at $V_{CC} = 5.0V$, $T_A = 25^\circ C$.

| Symbol | Parameter | Conditions | Min | Typ | Max | Units |
|-------------------------|--|---|-----|-----|------|-------|
| t_{DPLH} | Driver propagation delay (low to high) | $C_L = 50pF$, $R_L = 54\Omega$, Figure 7 | | | 25 | ns |
| t_{DPHL} | Driver propagation delay (high to low) | | | | 25 | ns |
| $ t_{DPLH} - t_{DPHL} $ | Differential driver output skew | | | | 5 | ns |
| t_{DR} , t_{DF} | Driver differential output rise or fall time | | | | 15 | ns |
| | Maximum data rate | $1/t_{UI}$, duty cycle 40% to 60% | 20 | | | Mbps |
| t_{DZH} | Driver enable to output high | $C_L = 50pF$, $R_L = 500\Omega$, Figure 8 | | | 60 | ns |
| t_{DZL} | Driver enable to output low | | | | 60 | ns |
| t_{DZH} | Driver disable from output high | | | | 250 | ns |
| t_{DLZ} | Driver disable from output low | | | | 250 | ns |
| $t_{DZH}(SHDN)$ | Driver enable from shutdown to output high | $C_L = 50pF$, $R_L = 500\Omega$, Figure 8 | | | 2200 | ns |
| $t_{DZL}(SHDN)$ | Driver enable from shutdown to output low | | | | 2200 | ns |
| t_{SHDN} | Time to shutdown | Notes 1 and 2 | 50 | 200 | 600 | ns |

Receiver AC Characteristics - XR33058 (20Mbps)

Unless otherwise noted: $V_{CC} = 3.0V$ to $5.5V$, $T_A = T_{MIN}$ to T_{MAX} . Typical values are at $V_{CC} = 5.0V$, $T_A = 25^\circ C$.

| Symbol | Parameter | Conditions | Min | Typ | Max | Units |
|-------------------------|--|---|-----|-----|------|-------|
| t_{RPLH} | Receiver propagation delay (low to high) | $C_L = 15pF$, $V_{ID} = \pm 2V$, V_{ID} rise and fall times $< 15ns$, Figure 9 | | | 60 | ns |
| t_{RPHL} | Receiver propagation delay (high to low) | | | | 60 | ns |
| $ t_{RPLH} - t_{RPHL} $ | Receiver propagation delay skew | | | | 5 | ns |
| | Maximum data rate | $1/t_{UI}$, duty cycle 40% to 60% | 20 | | | Mbps |
| t_{RZH} | Receiver enable to output high | $C_L = 15pF$, $R_L = 1k\Omega$, Figure 10 | | | 50 | ns |
| t_{RZL} | Receiver enable to output low | | | | 50 | ns |
| t_{RZH} | Receiver disable from output high | | | | 50 | ns |
| t_{RLZ} | Receiver disable from output low | | | | 50 | ns |
| $t_{RZH}(SHDN)$ | Receiver enable from shutdown to output high | $C_L = 15pF$, $R_L = 1k\Omega$, Figure 10 | | | 2200 | ns |
| $t_{RZL}(SHDN)$ | Receiver enable from shutdown to output low | | | | 2200 | ns |
| t_{SHDN} | Time to shutdown | Notes 1 and 2 | 50 | 200 | 600 | ns |

NOTES:

- The transceivers are put into shutdown by bringing \overline{RE} high and DE low simultaneously for at least 600ns. If the control inputs are in this state for less than 50ns, the device is guaranteed to not enter shutdown. If the enable inputs are held in this state for at least 600ns, the device is ensured to be in shutdown. Note that the receiver and driver enable times increase significantly when coming out of shutdown.
- This spec is guaranteed by design and bench characterization.

Pin Configuration



XR33052, XR33055 and XR33058 Half-duplex



XR33053 Full-duplex

Pin Functions

| Pin Number | | Pin Name | Type | Description |
|--|------------------------|-----------------|--------|--|
| Half-duplex XR33052 XR33055 XR33058 | Full-duplex XR33053 | | | |
| 1 | 2 | RO | Output | Receiver output. When \overline{RE} is low and if $(A-B) \geq 200mV$, RO is high. If $(A-B) \leq -200mV$, RO is low. If inputs are left floating, shorted together or terminated and undriven for more than $2\mu s$, the output is high. |
| 2 | 3 | \overline{RE} | Input | Receiver output enable (hot swap). When \overline{RE} is low, RO is enabled. When \overline{RE} is high, RO is high impedance, \overline{RE} should be high and DE should be low to enter shutdown mode. |
| 3 | 4 | DE | Input | Driver output enable (hot swap). When DE is high, outputs are enabled. When DE is low, outputs are high impedance, DE should be low and \overline{RE} should be high to enter shutdown mode. |
| 4 | 5 | DI | Input | Driver input. With DE high, a low level on DI forces non-inverting output low and inverting output high. Similarly, a high level on DI forces non-inverting output high and inverting output low. |
| 5 | 6, 7 | GND | Power | Ground. |
| 8 | 14 | VCC | Power | 3.0V to 5.5V power supply input, bypass to ground with $0.1\mu F$ capacitor. |
| | 12 | A | Input | Non-inverting receiver input. |
| | 11 | B | Input | Inverting receiver input. |
| | 9 | Y | Output | Non-inverting driver output. |
| | 10 | Z | Output | Inverting driver output. |
| 6 | | A/Y | I/O | Non-inverting receiver input and non-inverting driver output. |
| 7 | | B/Z | I/O | Inverting receiver input and inverting driver output. |
| | 1, 8, 13 | N/C | - | Not connected. |

Pin Functions (Continued)

| Transmitting | | | | |
|-----------------|----|----|-------------------|---|
| Inputs | | | Outputs | |
| \overline{RE} | DE | DI | Y | Z |
| X | 1 | 1 | 1 | 0 |
| X | 1 | 0 | 0 | 1 |
| 0 | 0 | X | High-Z | |
| 1 | 0 | X | High-Z (shutdown) | |

| Receiving | | | |
|-----------------|----|-------------------|-------------------|
| Inputs | | | Output |
| \overline{RE} | DE | $V_A - V_B$ | RO |
| 0 | X | $\geq 200mV$ | 1 |
| 0 | X | $\leq -200mV$ | 0 |
| 0 | X | Open/shorted/idle | 1 |
| 1 | 1 | X | High-Z |
| 1 | 0 | X | High-Z (shutdown) |

Applications Information



XR33052, XR33055 and XR33058



XR33053

Figure 2. XR33052, XR33055 and XR33058 Half-duplex and XR33053 Full-duplex



Figure 3. Differential Driver Output Voltage



Figure 4. Differential Driver Output Voltage Over Common Mode

Applications Information (Continued)



Figure 5. Driver Output Short Circuit Current

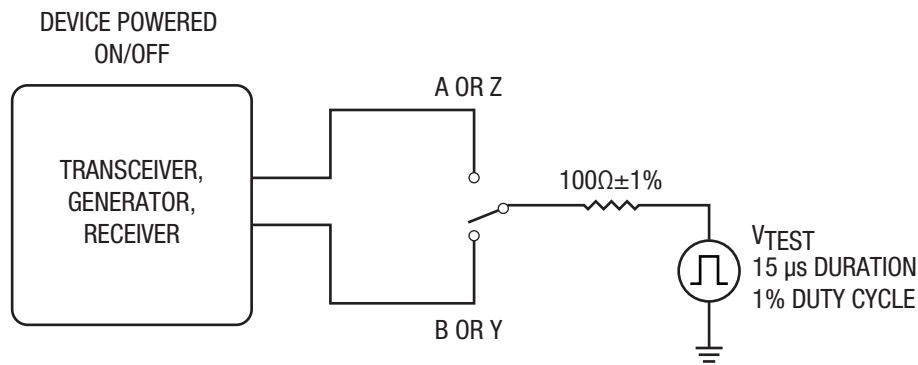

Figure 6. Transient Overvoltage Test Circuit



Figure 7. Driver Propagation Delay Test Circuit and Timing Diagram

Applications Information (Continued)



Figure 8. Driver Enable and Disable Timing Test Circuits and Timing Diagrams

Applications Information (Continued)



Figure 9. Receiver Propagation Delay Test Circuit and Timing Diagram

Applications Information (Continued)



Figure 10. Receiver Enable and Disable Test Circuits and Timing Diagrams

Applications Information (Continued)

The XR3305x RS-485/RS-422 devices are part of MaxLinear's high performance serial interface product line. The analog bus pins can survive direct shorts up to $\pm 60\text{V}$ and are protected against ESD events up to $\pm 15\text{kV}$.

Enhanced Failsafe

Ordinary RS-485 differential receivers will be in an indeterminate state whenever the data bus is not being actively driven. The enhanced failsafe feature of the XR3305x guarantees a logic-high receiver output when the receiver inputs are open, shorted or when they are connected to a terminated transmission line with all drivers disabled. In a terminated bus with all transmitters disabled, the receivers' differential input voltage is pulled to 0V by the termination. The XR3305x interprets 0V differential as a logic high with a minimum 50mV noise margin while maintaining compliance with the RS-485 standard of $\pm 200\text{mV}$. Although the XR3305x does not need failsafe biasing resistors, it can operate without issue if biasing is used.

Hot Swap Capability

When V_{CC} is first applied, the XR3305x holds the driver enable and receiver enable inactive for approximately 10 μs . During power ramp-up, other system ICs may drive unpredictable values or tristated lines may be influenced by stray capacitance. The hot swap feature prevents the XR3305x from driving any output signal until power has stabilized. After the initial 10 μs , the driver and receiver enable pins are weakly pulled to their disabled states (low for DE, high for $\overline{\text{RE}}$) until the first transition. After the first transition, the DE and $\overline{\text{RE}}$ pins operate as high impedance inputs.

If circuit boards are inserted into an energized backplane (commonly called "live insertion" or "hot swap") power may suddenly be applied to all circuits. Without the hot swap capability, this situation could improperly enable the transceiver's driver or receiver, driving invalid data onto shared buses and possibly causing driver contention or device damage.

Driver Output Protection

Two mechanisms prevent excessive output current and power dissipation caused by faults or by bus contention. First, a driver current limit on the output stage provides immediate protection against short circuits over the whole common-mode voltage range. Second, a thermal shutdown circuit forces the driver outputs into a high-impedance state if junction temperature becomes excessive.

Line Length

The RS-485/RS-422 standard covers line lengths up to 4000ft. Maximum achievable line length is a function of signal attenuation and noise. Termination prevents signal reflections by eliminating the impedance mismatches on a transmission line. Line termination is generally used if

rise and fall times are shorter than the round-trip signal propagation time. Higher output drivers may allow longer cables to be used.

$\pm 15\text{kV}$ HBM ESD Protection (Unpowered Part)

ESD protection structures are incorporated on all pins to protect against electrostatic discharges encountered during handling and assembly. The driver outputs and receiver inputs of the XR3305x family have extra protection against static electricity. MaxLinear uses state-of-the-art structures to protect these pins against ESD damage:

- $\pm 15\text{kV}$ HBM for bus pins to GND
- $\pm 4\text{kV}$ HBM for all other pins

ESD Test Conditions

ESD performance depends on a variety of conditions. Contact MaxLinear for a reliability report that documents test setup, methodology and results.

Maximum Number of Transceivers on the Bus

The standard RS-485 receiver input impedance is 12k Ω (1 unit load). A standard driver can drive up to 32 unit loads. The XR33052/53/55 transceiver has a 1/10th unit load receiver input impedance of 120k Ω , allowing up to 320 transceivers to be connected in parallel on a communication line. The XR33058 receiver input impedance is a least 30K Ω (1/2.5 unit load), allowing more than 80 devices on the bus. Any combination of the XR3305x's and other RS-485 transceivers up to a total of 32 unit loads may be connected to the line.

Low Power Shutdown Mode

Low power shutdown mode is initiated by bringing both $\overline{\text{RE}}$ high and DE low simultaneously. While in shutdown devices draw less than 1 μA of supply current. DE and $\overline{\text{RE}}$ may be tied together and driven by a single control signal. Devices are guaranteed not to enter shutdown if $\overline{\text{RE}}$ is high and DE is low for less than 50ns. If the inputs are in this state for at least 600ns, the parts will enter shutdown.

Enable times t_{ZH} and t_{ZL} apply when the part is not in low power shutdown state. Enable times $t_{ZH(\text{SHDN})}$ and $t_{ZL(\text{SHDN})}$ apply when the parts are shutdown. The driver and receiver take longer to become enabled from low power shutdown $t_{ZH(\text{SHDN})}$ and $t_{ZL(\text{SHDN})}$ than from driver or receiver disable mode (t_{ZH} and t_{ZL}).

Applications Information (Continued)**Product Selector Guide**

| Part Number | Operation | Data Rate | Shutdown | Receiver/Driver Enable | Nodes On Bus | Footprint |
|-------------|-------------|-----------|----------|------------------------|--------------|-----------|
| XR33052 | Half-duplex | 250kbps | Yes | Yes/Yes | 320 | 8-NSOIC |
| XR33053 | Full-duplex | 1Mbps | | | | 14-NSOIC |
| XR33055 | Half-duplex | | | | 8-NSOIC | |
| XR33058 | Half-duplex | 20Mbps | | | 80 | |

Mechanical Dimensions

NSOIC-8

Top View

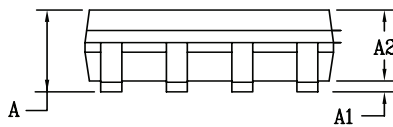
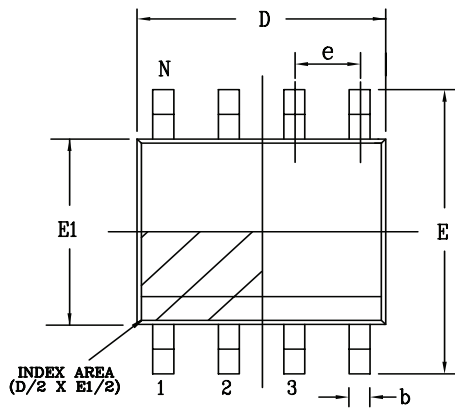

Side View

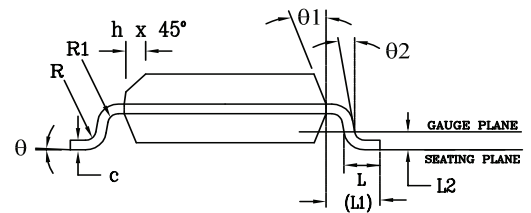

Front View

| PACKAGE OUTLINE NSOIC .150" BODY JEDEC MS-012 VARIATION AA | | | | | | |
|---|---|-----|------|---|-----|-------|
| SYMBOLS | COMMON DIMENSIONS IN MM (Control Unit) | | | COMMON DIMENSIONS IN INCH (Reference Unit) | | |
| | MIN | NOM | MAX | MIN | NOM | MAX |
| A | 1.35 | — | 1.75 | 0.053 | — | 0.069 |
| A1 | 0.10 | — | 0.25 | 0.004 | — | 0.010 |
| A2 | 1.25 | — | 1.65 | 0.049 | — | 0.065 |
| b | 0.31 | — | 0.51 | 0.012 | — | 0.020 |
| c | 0.17 | — | 0.25 | 0.007 | — | 0.010 |
| E | 6.00 BSC | | | 0.236 BSC | | |
| E1 | 3.90 BSC | | | 0.154 BSC | | |
| e | 1.27 BSC | | | 0.050 BSC | | |
| h | 0.25 | — | 0.50 | 0.010 | — | 0.020 |
| L | 0.40 | — | 1.27 | 0.016 | — | 0.050 |
| L1 | 1.04 REF | | | 0.041 REF | | |
| L2 | 0.25 BSC | | | 0.010 BSC | | |
| R | 0.07 | — | — | 0.003 | — | — |
| R1 | 0.07 | — | — | 0.003 | — | — |
| q | 0° | — | 8° | 0° | — | 8° |
| q1 | 5° | — | 15° | 5° | — | 15° |
| q2 | 0° | — | — | 0° | — | — |
| D | 4.90 BSC | | | 0.193 BSC | | |
| N | 8 | | | 8 | | |

Drawing No: POD-0000108
Revision: A

Mechanical Dimensions

NSOIC-14

Top View

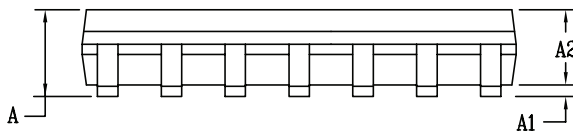

Side View

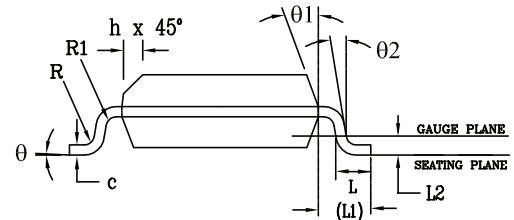

Front View

| PACKAGE OUTLINE NSOIC .150" BODY JEDEC MS-012 VARIATION AB | | | | | | |
|---|---|-----|------|---|-----|-------|
| SYMBOLS | COMMON DIMENSIONS IN MM (Control Unit) | | | COMMON DIMENSIONS IN INCH (Reference Unit) | | |
| | MIN | NOM | MAX | MIN | NOM | MAX |
| A | 1.35 | — | 1.75 | 0.053 | — | 0.069 |
| A1 | 0.10 | — | 0.25 | 0.004 | — | 0.010 |
| A2 | 1.25 | — | 1.65 | 0.049 | — | 0.065 |
| b | 0.31 | — | 0.51 | 0.012 | — | 0.020 |
| c | 0.17 | — | 0.25 | 0.007 | — | 0.010 |
| E | 6.00 BSC | | | 0.236 BSC | | |
| E1 | 3.90 BSC | | | 0.154 BSC | | |
| e | 1.27 BSC | | | 0.050 BSC | | |
| h | 0.25 | — | 0.50 | 0.010 | — | 0.020 |
| L | 0.40 | — | 1.27 | 0.016 | — | 0.050 |
| L1 | 1.04 REF | | | 0.041 REF | | |
| L2 | 0.25 BSC | | | 0.010 BSC | | |
| R | 0.07 | — | — | 0.003 | — | — |
| R1 | 0.07 | — | — | 0.003 | — | — |
| q1 | 0° | — | 8° | 0° | — | 8° |
| q1 | 5° | — | 15° | 5° | — | 15° |
| q2 | 0° | — | — | 0° | — | — |
| D | 8.65 BSC | | | 0.341 BSC | | |
| N | 14 | | | | | |

Drawing No: POD-00000109

Revision: A

Ordering Information⁽¹⁾

| Part Number | Operating Temperature Range | Lead-Free | Package | Packaging Method |
|--|-----------------------------|--------------------|-------------|------------------|
| XR33052ID-F | -40°C to 85°C | Yes ⁽²⁾ | 8-pin SOIC | Tube |
| XR33052IDTR-F | | | | Reel |
| XR33052HD-F | -40°C to 105°C | | | Tube |
| XR33052HDTR-F | | | | Reel |
| XR33053ID-F | -40°C to 85°C | | 14-pin SOIC | Tube |
| XR33053IDTR-F | | | | Reel |
| XR33053HD-F | -40°C to 105°C | | | Tube |
| XR33053HDTR-F | | | | Reel |
| XR33055ID-F | -40°C to 85°C | | 8-pin SOIC | Tube |
| XR33055IDTR-F | | | | Reel |
| XR33055HD-F | -40°C to 105°C | | | Tube |
| XR33055HDTR-F | | | | Reel |
| XR33058IDTR-F | -40°C to 85°C | | | Reel |
| XR33058HD-F | | | | Tube |
| XR33058HDTR-F | -40°C to 105°C | | | Reel |
| XR33052IDEVB XR33052HDEVB XR33053IDEVB XR33053HDEVB XR33055IDEVB XR33055HDEVB XR33058IDEVB XR33058HDEVB | Evaluation Boards | | | |

NOTE:

1. Refer to www.exar.com/XR33052, www.exar.com/XR33053, www.exar.com/XR33055, www.exar.com/XR33058 for most up-to-date Ordering Information.
2. Visit www.exar.com for additional information on Environmental Rating.