



## Metal Oxide Varistor

### G series Varistor

**Series/Type:** G14/20 series  
**Ordering code:** Z62000Z2310Z xx  
**Date:** 2022-09-30  
**Version:** Preliminary 2 (only for prototype sample test, not ready for series production)

### Applications

- Solar
- Power Supplies
- LED Applications
- Charges
- Surge Protection Devices
- White Goods
- Communications

### Construction

- Round varistor in series with arrester, leaded
- Coating: epoxy , flame-retardant to UL 94 V-0
- Terminals: tinned copper wire, metal compound wire

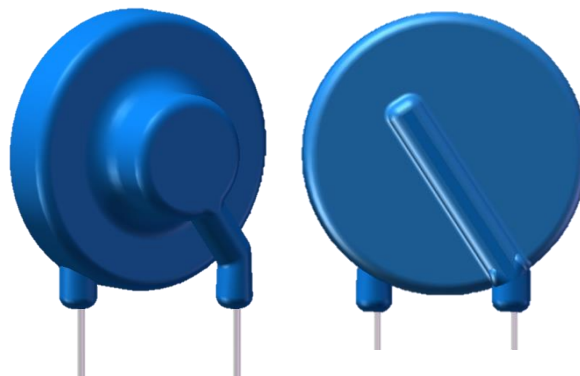

### Features

- Hybrid design (GDT+MOV)
- Low leakage
- RoHS complaint

### General technical data

Climatic category to IEC 60068-1	40 / 85 / 56
Operating temperature	-40...+85 °C
Storage temperature	-40...+85 °C
Coating material	UL94-V0
Application altitude	<2000 m

### Nomenclature

- G = Series designation  
 14/20 = Rated disk diameter (mm)  
 K = Tolerance of  $V_v$  at 1 mA:  $\pm 10\%$   
 150 ... 320 = Max. operating AC voltage

Dimensional drawing in mm

G14 series:

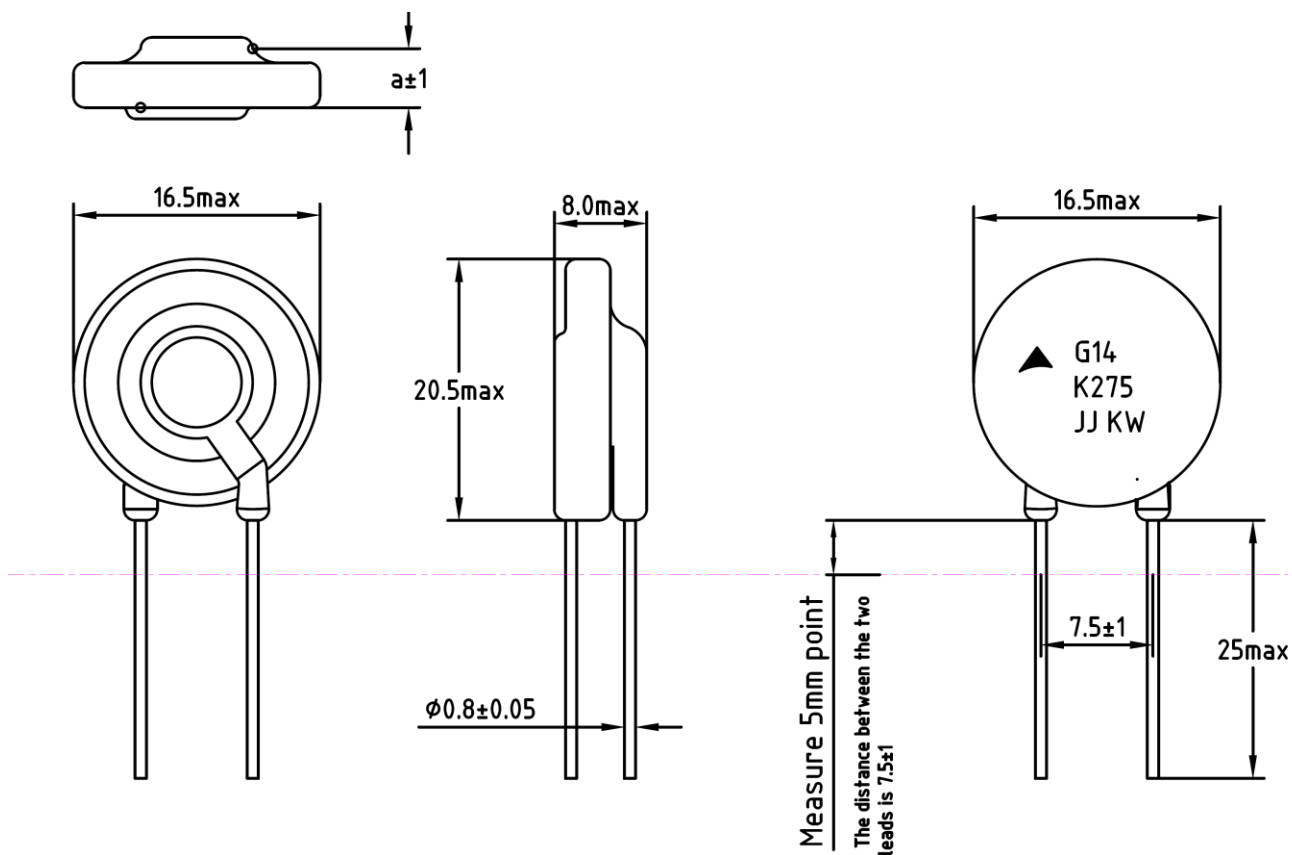

Type	Ordering code	a (mm) $\pm 1$
G14K150	Z62000Z2310Z 11	4.0
G14K275	Z62000Z2310Z 12	4.4
G14K275	Z62000Z2310Z 13	4.6
G14K320	Z62000Z2310Z 14	4.9

G20 series:

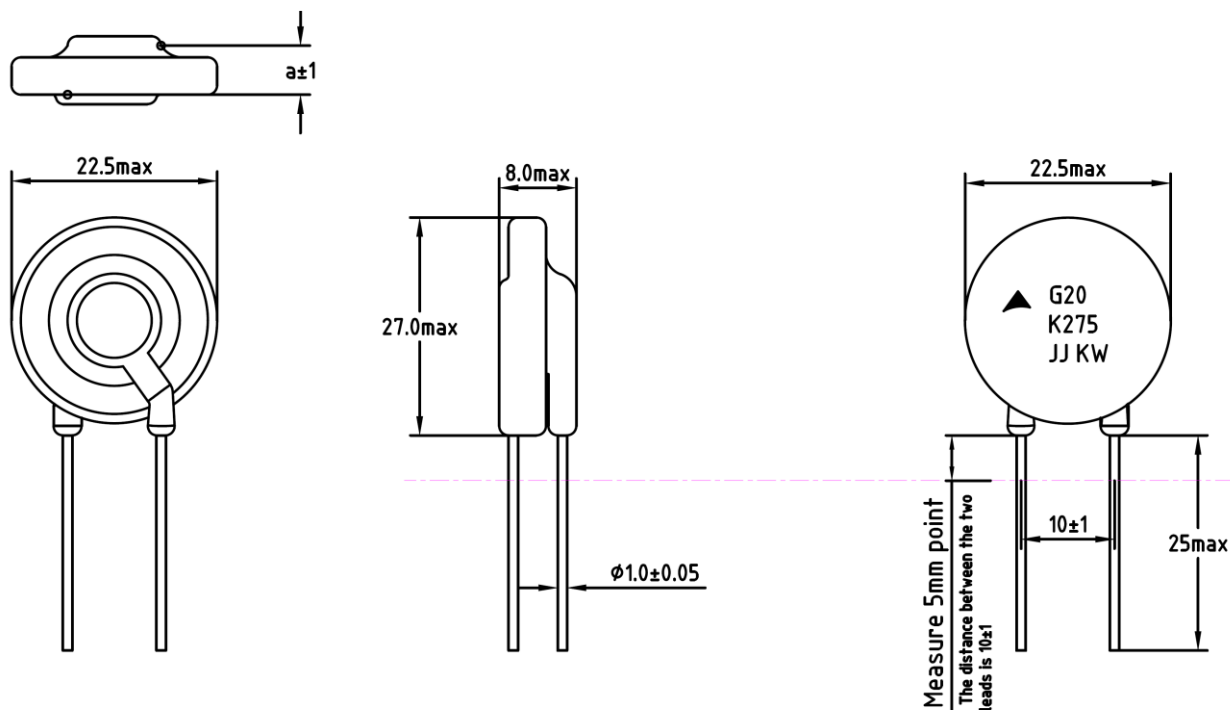

Type	Ordering code	a (mm) ±1
G20K150	Z62000Z2310Z 15	4.2
G20K230	Z62000Z2310Z 16	4.6
G20K275	Z62000Z2310Z 17	4.8
G20K320	Z62000Z2310Z 18	5.1

**Electrical specifications**
**Characteristics (25 °C)**

Type	DC spark-over voltage	Max. operating voltage		$I_n$	$I_{max}$	Max. Leakage	Max. Clamping Voltage		$W_{max}$	$P_{max}$	
		$V_{RMS}$	$V_{DC}$								
SIOV	V	V	V	8/20 $\mu s^*)$	8/20 $\mu s^*)$	At $V_{DC}$	Vc	A	2 ms	J	W
G14K150	480-720	150	200	3	6	0.1	580	1000	70	0.6	
G14K230	800-1200	230	300	3	6	0.1	900	1000	105	0.6	
G14K275	800-1200	275	350	3	6	0.1	1050	1000	130	0.6	
G14K320	800-1200	320	415	3	6	0.1	1300	1000	150	0.6	

Type	DC spark-over voltage for GDT	Max. operating voltage		$I_n$	$I_{max}$	Max. Leakage	Max. Clamping Voltage		$W_{max}$	$P_{max}$	
		$V_{RMS}$	$V_{DC}$								
SIOV	V	V	V	8/20 $\mu s^*)$	8/20 $\mu s^*)$	At $V_{DC}$	Vc	A	2 ms	J	W
G20K150	480-720	150	200	5	10	0.1	530	1000	120	1	
G20K230	800-1200	230	300	5	10	0.1	820	1000	180	1	
G20K275	800-1200	275	350	5	10	0.1	950	1000	260	1	
G20K320	800-1200	320	415	5	10	0.1	1150	1000	320	1	

<sup>\*)</sup> Surge test acc. IEC61643-11

Remark:

Above sample is not mass product. These samples can only be used for testing.

## Cautions and warnings

### General

1. TDK Electronics metal oxide varistors are designed for specific applications and should not be used for purposes not identified in our specifications, application notes and data books unless otherwise agreed with TDK Electronics during the design-in-phase.
2. Ensure suitability of SIOVs through reliability testing during the design-in phase. SIOVs should be evaluated taking into consideration worst-case conditions.
3. For applications of SIOVs in line-to ground circuits based on various international and local standards there are restrictions existing or additional safety measures required.

### Storage

After shipment from TDK Electronics the SIOV type series should be soldered within the following time period:

SIOV-S,-Q,L(S),-SNF,-ICL,-B,-E,-G	24 months
SIOV-ETFV,-T,-SMD,-MT-EM,-NT	12 months

The parts are to be left in the original packing to prevent oxidized terminals which can cause soldering problems.

Storage temperature:	-25 to 45°C
Max. relative humidity(without condensation):	<75% annual average, <95% on max. 30 days per annum.

### Handling

1. SIOVs must not be dropped.
2. Components must not be touched with bare hands. Gloves are recommended.
3. Avoid contamination of the surface of SIOV electrodes during handling, be careful of the sharp edge of SIOV electrodes.

### Soldering (where applicable)

1. Use rosin-type flux or non-activated flux.
2. Insufficient preheating may cause ceramic cracks.
3. Rapid cooling by dipping in solvent is not recommended.
4. Complete removal of flux is recommended.

5. Temperature of all preheat stages and the solder bath must be strictly controlled especially for T series(T14 and T20)

### Mounting

1. Potting, sealing or adhesive compounds can produce chemical reactions in the SIOV ceramic that will degrade the component's electrical characteristics.
2. Overloading SIOVs may result in ruptured packages and expulsion of hot materials. For this reason SIOVs should be physically shielded from adjacent components.

### Operation

1. Use SIOVs only within the specified temperature operating range
2. Use SIOVs only within the specified voltage and current ranges.
3. Environmental conditions must not harm the SIOVs. Use SIOVs only in normal atmospheric conditions. Avoid use in deoxidizing gases (chlorine gas, hydrogen sulfide gas, ammonia gas, sulfuric acid gas, etc), corrosive agents, humid or salty conditions. Contact with any liquids and solvents should be prevented.

### Display of ordering codes for TDK Electronics products

The ordering code for one and the same product can be represented differently in data sheets, data books, other publications, on the company website, or in order-related documents such as shipping notes, order confirmations and product labels. **The varying representations of the ordering codes are due to different processes employed and do not affect the specifications of the respective products.** Detailed information can be found on the Internet under [www.tdk-electronics.tdk.com/orderingcodes](http://www.tdk-electronics.tdk.com/orderingcodes).