

Electromagnetic shaker system

F4/Z820WA

SPECIFICATIONS

Usable frequency range	10 - 7,500 Hz
Blocked force output ¹	see graph on page 2
Maximum continuous current	1.5 amps rms
Maximum continuous current with air cooling	2.5 amps rms
Nominal electrical impedance	25 Ω
DC electrical resistance	13 Ω
Resonance frequency, blocked	40 Hz, nominal
Forced air cooling pressure, max	25 psi (1.7 bar)
Connector ²	Bendix PT06A-8-3S
Cable	R4M-8B-8B-J9B-10
Accelerometer nominal values:	
Voltage sensitivity	100 mV/g
Frequency response:	10 - 2,000 Hz
±0.5 dB	6 - 3,000 Hz
±1.0 dB	3 - 6,000 Hz
±3.0 dB	
Power requirements: voltage source	18 - 30 VDC
current regulating diode	2 - 10 mA
Bias output voltage, nominal	12 VDC
Output impedance	<100 Ω
Electrical noise, equiv. g:	
Spectral	
10 Hz	100 µg/√Hz
100 Hz	10 µg/√Hz
1,000 Hz	1 µg/√Hz
Connector ²	BNC
Output cable	R2-2-J5A-10
Force gage nominal values:	
Voltage sensitivity	100 mV/lb (22.5 mV/N)
Power requirements: voltage source	18 - 30 VDC
current regulating diode	2 - 10 mA
Bias output voltage, nominal	12 VDC
Output impedance	<100 Ω
Electrical noise, equiv. lb:	
Spectral	
10 Hz	60 µlb/√Hz (270 µN/√Hz)
100 Hz	10 µlb/√Hz (44 µN/√Hz)
1,000 Hz	1 µlb/√Hz (4.4 µN/√Hz)
Connector ²	BNC
Output cable	R2-2-J5A-10
Mass below force gage (including stud)	140 grams (0.31 lb)
Effective stiffness ³	>500 x 10 ⁶ lb/in (87 x 10 ⁹ N/m)
Diameter of mounting surface	1.62 in. (4.1 cm)
Mounting stud, stainless steel	3/8-16 UNC
Recommended screw down torque	70 lb/in (7.9 N/m)
Temperature range	0° to +80°C
Base material	anodized aluminum
Weight: Parts rigidly attached to structure	2.0 lb (0.9 kg)
Suspended weight	4.8 lb (2.2 kg)
Total weight	6.8 lb (3.1 kg)



Key features

- Reaction-type shaker generates very large dynamic forces for research and testing
- Air-cooling feature for operation at high output levels for long periods
- Designed for operation over a wide range of audio frequencies
- Manufactured in ISO 9001 facility

See reverse for dimensions, graphs and system diagram.

Notes: ¹ Blocked force output refers to the force output against a mass of infinite mechanical impedance.

² Refers to connector at shaker end of cable.

³ The design of the Z820WA is such that the limiting stiffness which can be measured with an accuracy of 10% is determined by the local stiffness of the specimen under test. For a thick steel specimen this stiffness is approximately one tenth of the actual local stiffness or 7,000,000 lb/in; for an aluminum specimen it is approximately 2,000,000 lb/in.

Accessories supplied: All input and output cables; mounting stud; spanner wrench; adaptor cable

Note: Due to continuous process improvement, specifications are subject to change without notice. This document is cleared for public release.

Electromagnetic shaker system

F4/Z820WA

Recommended system diagram

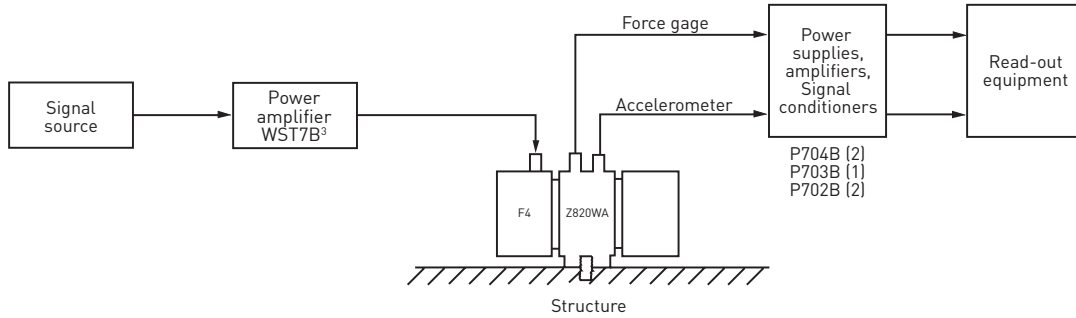

Typical blocked force output
[F4 shaker powered by WST7B³]

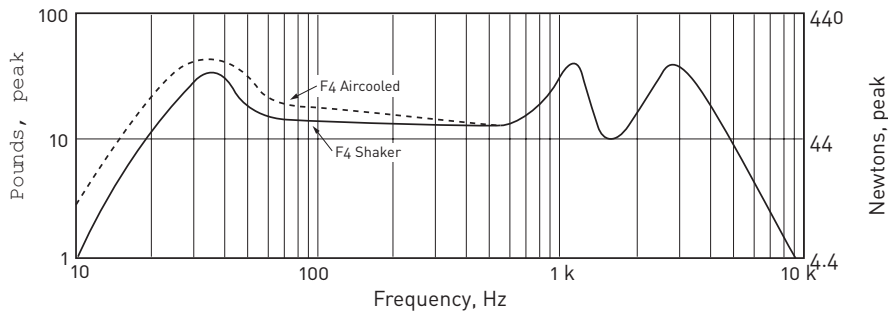

Dimensions

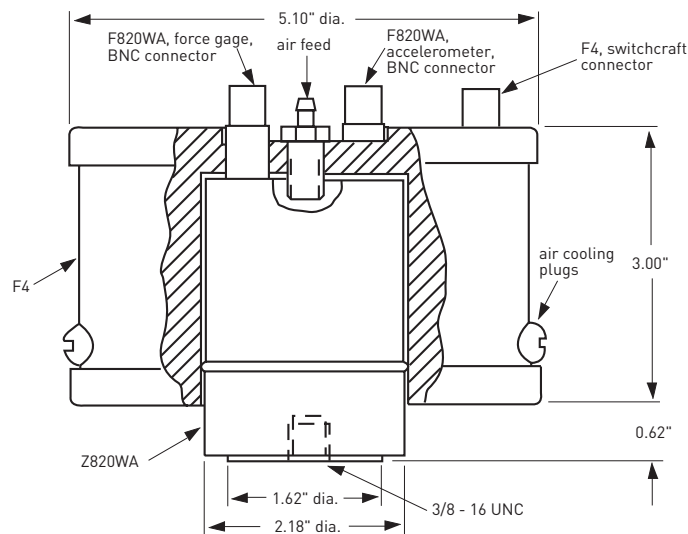

Note: Due to continuous process improvement, specifications are subject to change without notice. This document is cleared for public release.