

# Coaxial Bias-Tee

50Ω Wideband 0.1 to 4200 MHz

## ZFBT-4R2GW+



Generic photo used for illustration purposes only

CASE STYLE: K18

Connectors Model  
SMA ZFBT-4R2GW+  
BRACKET (OPTION "B")

**+RoHS Compliant**  
The +Suffix identifies RoHS Compliance. See our web site for RoHS Compliance methodologies and qualifications

### Maximum Ratings

Operating Temperature	-55°C to 100°C
Storage Temperature	-55°C to 100°C
RF Power	30 dBm max.
Voltage at DC port	30 V max.
Input Current	500 mA
DC resistance from DC to RF&DC port	4.5 ohm typ.

Permanent damage may occur if any of these limits are exceeded.

### Coaxial Connections

RF	1 (SMA female)
RF&DC	2 (SMA male)
DC	3 (SMA female)

### Features

- wideband, 0.1 to 4200 MHz
- low insertion loss, 0.6 dB typ.
- good isolation, 40 dB typ.

### Applications

- biasing amplifiers
- biasing of laser diodes
- biasing of active antennas
- DC return
- DC blocking
- test accessory

### Outline Drawing

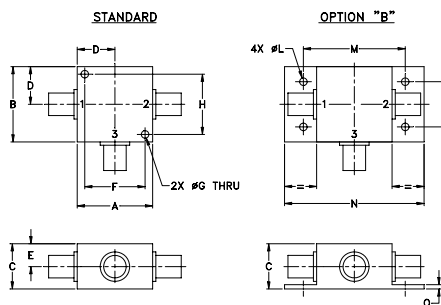

### Outline Dimensions (inch mm)

A	B	C	D	E	F	G	H
1.25	1.25	.75	.63	.38	1.00	.125	1.000
31.75	31.75	19.05	16.00	9.65	25.40	3.18	25.40

J	K	L	M	N	P	Q	wt
--	--	.125	1.688	2.18	.75	.07	grams
--	--	3.18	42.88	55.37	19.05	1.78	70.0

#### Notes

- A. Performance and quality attributes and conditions not expressly stated in this specification document are intended to be excluded and do not form a part of this specification document.  
 B. Electrical specifications and performance data contained in this specification document are based on Mini-Circuit's applicable established test performance criteria and measurement instructions.  
 C. The parts covered by this specification document are subject to Mini-Circuits standard limited warranty and terms and conditions (collectively, "Standard Terms"); Purchasers of this part are entitled to the rights and benefits contained therein. For a full statement of the Standard Terms and the exclusive rights and remedies thereunder, please visit Mini-Circuits' website at [www.minicircuits.com/MCLStore/terms.jsp](http://www.minicircuits.com/MCLStore/terms.jsp)

### Bias-Tee Electrical Specifications

FREQUENCY (MHz)		INSERTION LOSS* (dB)			ISOLATION* (dB) (RF port to DC port) (RF&DC port to DC port)			VSWR** (:1)											
$f_L$	$f_U$	L	M	U	L	M	U	L	M	U									
		Typ.	Max.	Typ.	Max.	Typ.	Max.	Typ.	Max.	Typ.	Max.								
0.1	4200	0.15	0.8	0.6	1.2	0.6	1.6	25	15	40	20	50	20	1.06	1.6	1.13	1.3	1.13	1.3

L= low range ( $f_L$  to 10  $f_L$ ) M= mid range (10  $f_L$  to  $f_U/2$ ) U= upper range ( $f_U/2$  to  $f_U$ )

\* Insertion Loss 1 dB Max. and Isolation 7 dB Min. 0.1 to 0.3 MHz.

Insertion Loss and Isolation are guaranteed up to 20 dBm-RF power and 200mA DC current.

\*\*VSWR measured with open and short at DC port.

### Typical Performance Data

Freq. (MHz)	Pin (dBm)	INSERTION LOSS (dB) with Current						ISOLATION (dB) (Pin=-10dBm) with current						VSWR (:1)
		0mA	20mA	50mA	100mA	150mA	200mA	10mA	20mA	50mA	100mA	150mA	200mA	
0.10	19.80	0.17	0.17	0.16	0.17	0.20	0.24	19.46	19.04	17.83	14.58	12.66	11.75	1.16
0.27	19.80	0.13	0.13	0.13	0.14	0.14	0.15	25.86	25.53	24.52	21.43	19.31	18.16	1.07
0.53	19.80	0.12	0.12	0.12	0.11	0.11	0.11	29.17	28.98	28.36	26.18	24.40	23.37	1.04
1.06	19.80	0.13	0.13	0.12	0.11	0.12	0.12	30.81	30.74	30.56	29.62	28.62	27.92	1.02
10.00	18.50	0.16	0.17	0.17	0.16	0.16	0.16	30.06	30.07	30.07	30.20	30.38	30.56	1.04
114.75	19.50	0.22	0.25	0.24	0.22	0.22	0.22	34.45	34.49	34.27	33.99	33.83	33.59	1.07
324.25	19.70	0.50	0.55	0.53	0.52	0.53	0.56	44.65	44.61	44.25	43.90	43.91	43.34	1.06
743.25	18.70	0.28	0.31	0.30	0.29	0.29	0.29	51.19	50.50	50.16	50.65	51.69	52.47	1.06
952.75	18.20	0.31	0.33	0.33	0.31	0.32	0.33	40.75	40.80	40.97	40.97	40.93	40.95	1.11
1581.25	18.00	0.46	0.48	0.47	0.46	0.48	0.49	42.58	42.59	43.94	43.77	44.36	44.17	1.13
2000.25	17.10	0.46	0.48	0.47	0.46	0.46	0.47	45.46	45.57	45.73	45.48	46.14	45.28	1.12
2524.00	14.40	0.40	0.42	0.41	0.42	0.43	0.44	53.15	53.72	52.19	53.17	52.67	53.67	1.12
3047.75	14.20	0.45	0.48	0.47	0.46	0.46	0.49	52.46	52.25	51.55	51.33	51.46	50.99	1.09
3676.25	15.10	0.73	0.74	0.75	0.75	0.75	0.75	46.32	47.19	46.36	45.53	46.19	45.65	1.07
4200.00	17.90	1.04	1.07	1.07	1.06	1.05	1.06	28.42	28.36	28.24	28.14	28.01	27.92	1.09
4502.50	-0.60	1.17	1.19	1.18	1.19	1.17	1.16	28.15	28.10	28.05	27.96	27.84	27.87	1.14
4802.00	-0.70	1.26	1.26	1.27	1.25	1.22	1.20	37.95	38.01	38.19	37.93	37.58	37.51	1.12
5251.75	-1.10	1.19	1.17	1.16	1.13	1.11	1.09	49.68	51.04	49.12	49.37	49.13	48.19	1.11
5550.75	-2.00	1.65	1.63	1.60	1.56	1.54	1.51	38.44	38.56	38.36	38.07	37.85	38.19	1.10
6000.00	-2.40	1.70	1.71	1.65	1.59	1.54	1.50	34.37	34.36	34.23	34.40	34.49	34.48	1.12

### Electrical Schematic

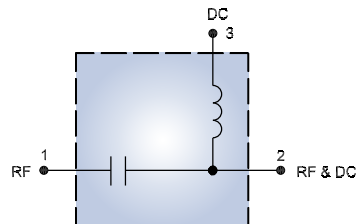

# Performance Charts

# ZFBT-4R2GW+

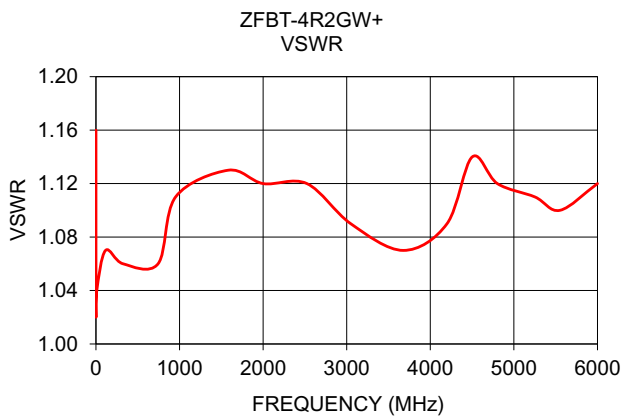
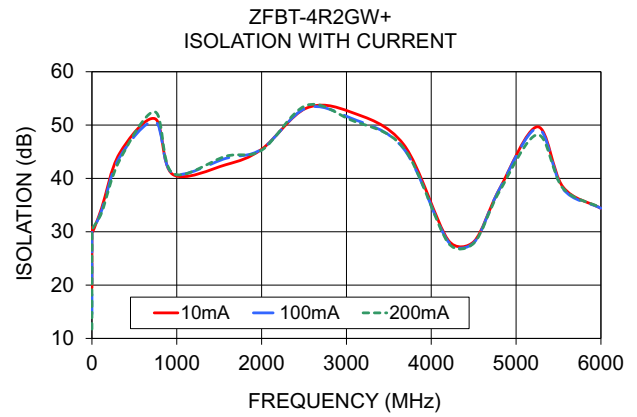
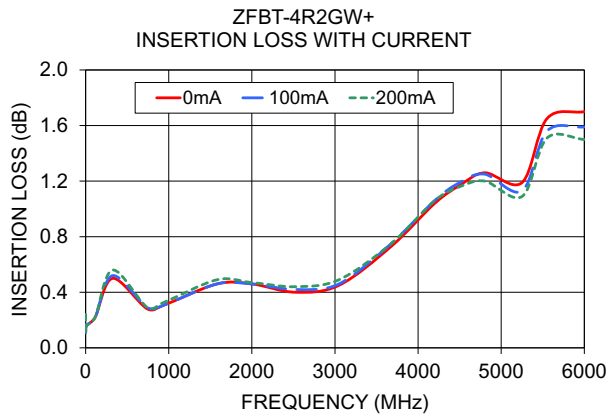

### Notes

- A. Performance and quality attributes and conditions not expressly stated in this specification document are intended to be excluded and do not form a part of this specification document.
- B. Electrical specifications and performance data contained in this specification document are based on Mini-Circuit's applicable established test performance criteria and measurement instructions.
- C. The parts covered by this specification document are subject to Mini-Circuits standard limited warranty and terms and conditions (collectively, "Standard Terms"); Purchasers of this part are entitled to the rights and benefits contained therein. For a full statement of the Standard Terms and the exclusive rights and remedies thereunder, please visit Mini-Circuits' website at [www.minicircuits.com/MCLStore/terms.jsp](http://www.minicircuits.com/MCLStore/terms.jsp)

