



COAXIAL HIGH IP3

Low Noise Amplifier

ZHL-2010+

50Ω Medium High Power 50 to 1000 MHz

FEATURES

- Wideband, 50 to 1000 MHz
- Low Noise, 3.7 dB typ.
- High IP3, +46 dBm typ.
- Very High IP2, +68 - +83 dBm typ.



Generic photo used for illustration purposes only

APPLICATIONS

- VHF/UHF
- Cellular
- Test Equipment
- Instrumentation
- Laboratory

Model No.	ZHL-2010+
Case Style	S32
Connectors	SMA

+RoHS Compliant
 The +Suffix identifies RoHS Compliance.
 See our website for methodologies and qualifications

ELECTRICAL SPECIFICATIONS

Parameter	Frequency (MHz)	Min	Typ	Max	Units
Frequency		50		1000	MHz
Gain	50-1000	20			dB
Gain Flatness	50-1000			±0.8	dB
Output Power at 1dB Compression	50-1000	+26			dBm
Noise Figure	50-1000		3.7		dB
Input IP3	50-1000		+46		dBm
Input VSWR	50-1000			2.0	:1
Output VSWR	50-1000			2.0	:1
DC Supply Voltage			+12		V
Supply Current				0.90	A

Open load is not recommended, potentially can cause damage.
 With no load derate max input power by 20 dB

ABSOLUTE MAXIMUM RATINGS

Parameter	Ratings
Operating Temperature	-20°C to +65°C
Storage Temperature	-55°C to +100°C
DC Voltage	+13V Max.
RF Input Power (no damage)	+11 dBm

Permanent damage may occur if any of these limits are exceeded.

REV. E
 ECO-017949
 ZHL-2010+
 MCL NY
 230524





COAXIAL HIGH IP3

Low Noise Amplifier

ZHL-2010+

Mini-Circuits

50Ω Medium High Power 50 to 1000 MHz

OUTLINE DRAWING

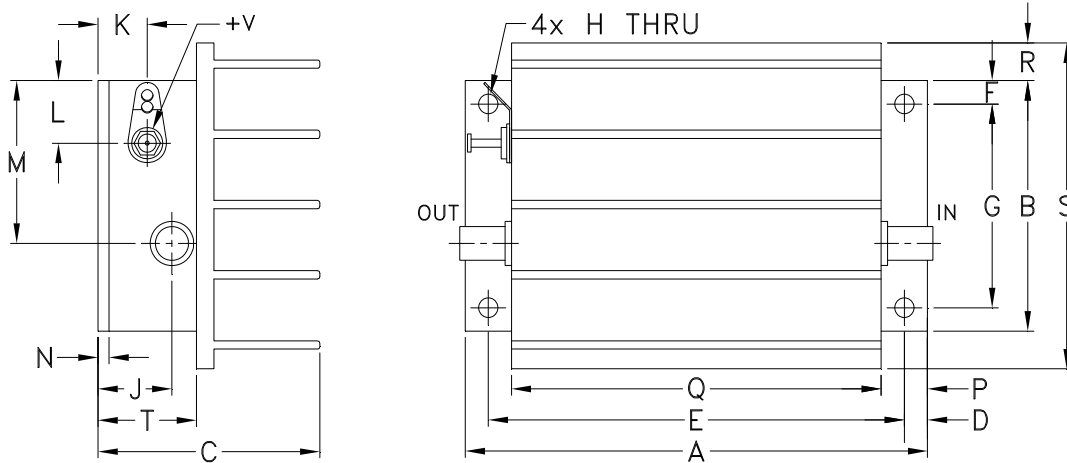

MOUNTING INFORMATION FOR MODELS WITHOUT HEATSINK

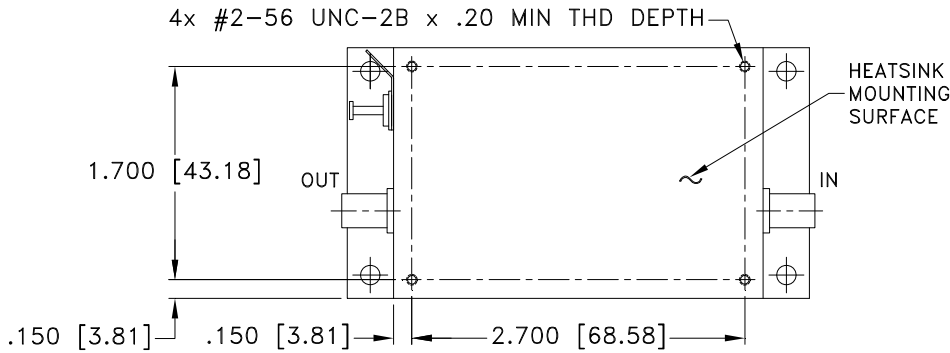

OUTLINE DIMENSIONS (Inch/mm)

A	B	C	D	E	F	G	H	J	K	L	M	N	P	Q	R	S	T	wt	
3.75	2.00	1.80	.19	3.375	.19	1.625	.144	.50	.40	.50	1.30	.10	.38	3.00	.30	2.60	.80	grams	
95.25	50.80	45.72	4.83	85.73	4.83	41.28	3.66	12.70	10.16	12.70	33.02	2.54	9.65	76.20	7.62	66.04	20.32	220.0	
																		wt. w/o heat sink	150