



COAXIAL

High Power Amplifier

ZHL-5W-202-S+ ZHL-5W-202X-S+

50Ω 5W 10 to 2000 MHz

THE BIG DEAL

- High Power, 5 Watt at saturation
- Class AB Amplifier
- Low Current consumption
- High IP3, +47 dBm typ.
- Usable from 5.0 MHz to 2200 MHz
- Good Gain Flatness, ±2.0 dB typ.
- No damage with an open or short output load while delivering up to 5W
- Shuts off when base plate temperature exceeds +85°C



Generic photo used for illustration purposes only

Model No.	ZHL-5W-202-S+	ZHL-5W-202X-S+▲
Case Style	BT1689-1	
Connectors	SMA	

+RoHS Compliant

The +Suffix identifies RoHS Compliance. See our website for methodologies and qualifications

APPLICATIONS

- Cellular
- PCN
- GSM
- ISM
- Lab Test

PRODUCT OVERVIEW

The ZHL-5W-202-S+ is a Class AB, high-power amplifier providing 5W saturated power over the 10 to 2000 MHz band, ideal for a variety of high-power test setups as well as applications including communications, radar and more. The ruggedly-designed amplifier provides unconditional stability and built-in self-protection against reverse polarity, excessive drive and overheating. The amplifier's output stage is further protected in the event of a fault condition, allowing high power operation into an OPEN or SHORT load (refer to the maximum input power specifications). Housed in a rugged aluminum alloy case measuring 4.3 x 6.7 x 1.2", the unit features SMA connectors and an optional heat sink and fan attachment for cooling.

KEY FEATURES

Feature	Advantages
Ultra Wideband, usable from 5.0 to 2200 MHz	Suitable for a broad range of high-power, wideband applications, including test setups, communications and defense applications.
High Gain, 50 dB	Enables signal amplification to 5W output without the need for multiple gain stages.
Built-in self-protection	In instances of potentially-damaging excessive drive current, heat buildup within the housing, unshorting of DC supply, and short or open loads at the output, an automatic sensing feature signals the unit to power down.
Unconditional stability	Provides reliable performance independent of input and load conditions.

REV. A
ECO-017723
ZHL-5W-202-S+
MCL NY
230502





COAXIAL

High Power Amplifier

ZHL-5W-202-S+ ZHL-5W-202X-S+

50Ω 5W 10 to 2000 MHz

ELECTRICAL SPECIFICATIONS AT 25°C

Parameter	Min.	Typ.	Max.	Units
Frequency Range	10		2000	MHz
Gain ¹	44	50	56	dB
Gain Flatness	—	±2.0	±2.7	dB
Output Power at 3dB compression	—	+38	—	dBm
Output Power at Saturation	+36	+40	—	dBm
Noise Figure	—	10	—	dB
Output third order intercept point	+39	+47	—	dBm
Input VSWR	—	1.2	—	:1
Output VSWR	—	2.0	—	:1
DC Supply Voltage	—	28	30	V
Supply Current ²	—	1.5	3.0	A

1. Small signal input power -50 dBm typ.

2. Power Supply should be capable of delivering 4A at start up.

▲ Heat sink and fan not included. Alternative heat sinking and heat removal must be provided by the user to limit maximum base-plate temperature to 85°C, in order to ensure proper performance. For reference, this requires thermal resistance of user's external heat sink to be 1.0°C/W max.

ABSOLUTE MAXIMUM RATINGS³

Parameter	Ratings
Operating Temperature	-20 °C to +60 °C
Storage Temperature	-55 °C to +100 °C
Base Plate Temperature	+85 °C
Input RF Power (no damage)	+5 dBm ⁴
	-19 dBm ⁵

3. Specifications apply to CW signals only permanent damage may occur if any of these limits are exceeded.

4. Into 50 ohm load.

5. Into open or short load





COAXIAL

High Power Amplifier

ZHL-5W-202-S+
ZHL-5W-202X-S+

Mini-Circuits

50Ω 5W 10 to 2000 MHz

OUTLINE DRAWING FOR MODELS WITH HEATSINK

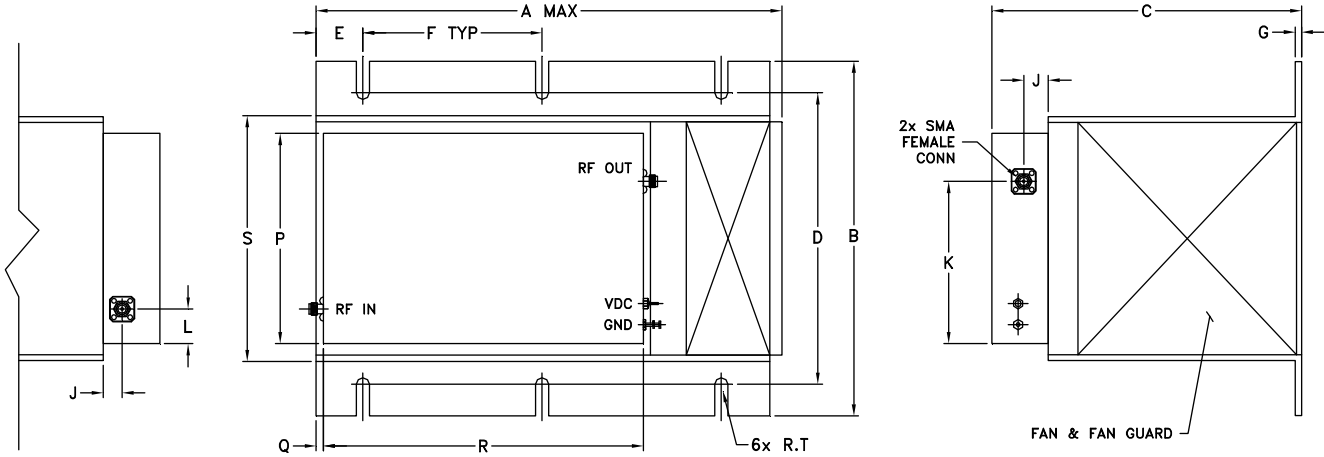

OUTLINE DRAWING FOR MODELS WITHOUT HEATSINK

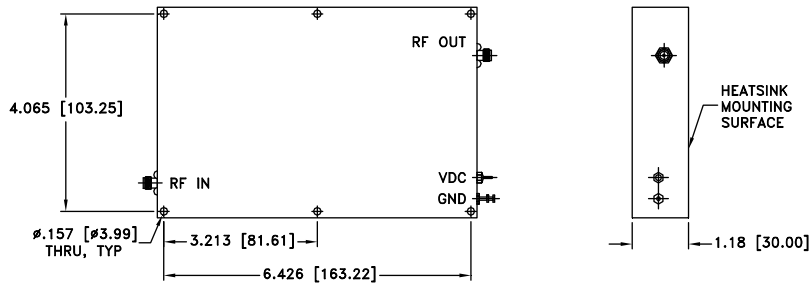

OUTLINE DIMENSIONS (Inch mm)

A	B	C	D	E	F	G	J	K	L	M	P	Q	R	S	T	wt
9.85	7.30	6.50	6.00	0.98	3.75	0.13	0.47	3.34	0.71	--	4.33	0.20	6.69	5.10	0.14	grams*
250.19	185.42	167.64	152.4	24.89	95.25	3.30	12.00	84.80	18.00	--	110.00	5.08	170.00	129.54	3.45	4565

*880 grams without heatsink

