



Features

Inputs/Outputs

- Accepts differential or single-ended input
 - LVPECL, LVDS, CML, HCSL, LVCMOS
- Two precision LVPECL outputs
- Operating frequency up to 750 MHz

Power

- Options for 2.5 V or 3.3 V power supply
- Core current consumption of 49 mA
- On-chip Low Drop Out (LDO) Regulator for superior power supply rejection

Performance

- Ultra low additive jitter of 39 fs RMS

Ordering Information

ZL40200LDG1	16 Pin QFN	Trays
ZL40200LDF1	16 Pin QFN	Tape and Reel

Matte Tin

Package size: 3 x 3 mm
-40°C to +85°C

Applications

- General purpose clock distribution
- Low jitter clock trees
- Logic translation
- Clock and data signal restoration
- Wired communications: OTN, SONET/SDH, GE, 10 GE, FC and 10G FC
- PCI Express generation 1/2/3 clock distribution
- Wireless communications
- High performance microprocessor clock distribution

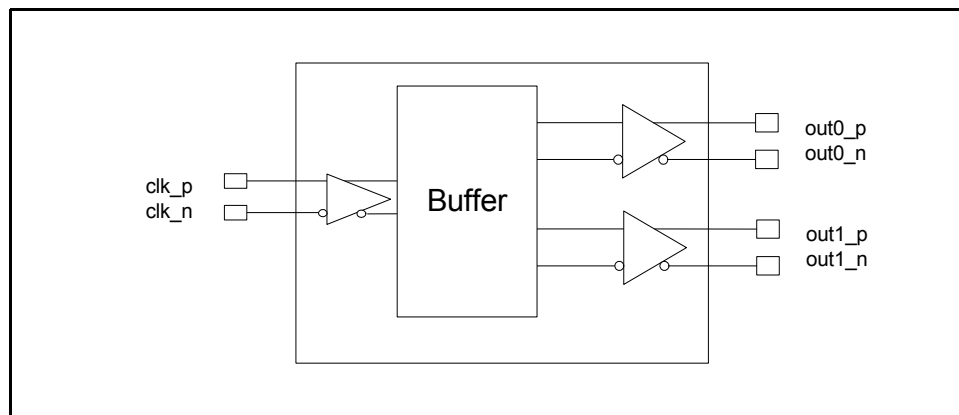

Figure 1 - Functional Block Diagram

Table of Contents

Features	1
Inputs/Outputs	1
Power	1
Performance	1
Applications	1
Change Summary	4
1.0 Package Description	5
2.0 Pin Description	5
3.0 Functional Description	6
3.1 Clock Inputs	6
3.2 Clock Outputs	11
3.3 Device Additive Jitter	15
3.4 Power Supply	16
3.4.1 Sensitivity to power supply noise	16
3.4.2 Power supply filtering	16
3.4.3 PCB layout considerations	16
4.0 AC and DC Electrical Characteristics	17
5.0 Performance Characterization	20
6.0 Typical Behavior	21
7.0 Package Thermal Characteristics	23
8.0 Mechanical Drawing	24

List of Figures

Figure 1 - Functional Block Diagram	1
Figure 2 - Pin Connections	5
Figure 3 - LVPECL Input DC Coupled Thevenin Equivalent	6
Figure 4 - LVPECL Input DC Coupled Parallel Termination	7
Figure 5 - LVPECL Input AC Coupled Termination	7
Figure 6 - LVDS Input DC Coupled	8
Figure 7 - LVDS Input AC Coupled	8
Figure 8 - CML Input AC Coupled	9
Figure 9 - HCSL Input AC Coupled	9
Figure 10 - CMOS Input DC Coupled Referenced to VDD/2	10
Figure 11 - CMOS Input DC Coupled Referenced to Ground	10
Figure 12 - Simplified Output Driver.	11
Figure 13 - LVPECL Basic Output Termination	11
Figure 14 - LVPECL Parallel Output Termination.	12
Figure 15 - LVPECL Parallel Thevenin-Equivalent Output Termination.	12
Figure 16 - LVPECL AC Output Termination for Externally Terminated LVPECL Inputs	13
Figure 17 - LVPECL AC Output Termination for Internally Terminated LVPECL Inputs.	13
Figure 18 - LVPECL AC-Coupled Output Termination for CML Inputs.	14
Figure 19 - Additive Jitter.	15
Figure 20 - Decoupling Connections for Power Pins	16
Figure 21 - Differential Voltage Parameter	18
Figure 22 - Input To Output Timing	19

Change Summary

Below are the changes from the February 2013 to the April 2014 issue:

Page	Item	Change
1	Applications	Added PCI Express clock distribution.
5	Pin Description	Added exposed pad to Pin Description.
6, 7	Figure 3 and Figure 4	Removed 22 Ohm series resistors from Figure 3 and 4. These resistors are not required; however there is no impact to performance if the resistors are included.
13	Figure 16	Corrected LVPECL interface circuit.
18	Figure 21	Clarification of V_{ID} and V_{OD} .

Below are the changes from the November 2012 issue to the February 2013 issue:

Page	Item	Change
7	Figure 4	Changed text to indicate the circuit is not recommended for $VDD_{driver}=2.5V$.
7	Figure 5	Changed pull-up and pull-down resistors from 2kOhm to 100 Ohm.

1.0 Package Description

The device is packaged in a 16 pin QFN

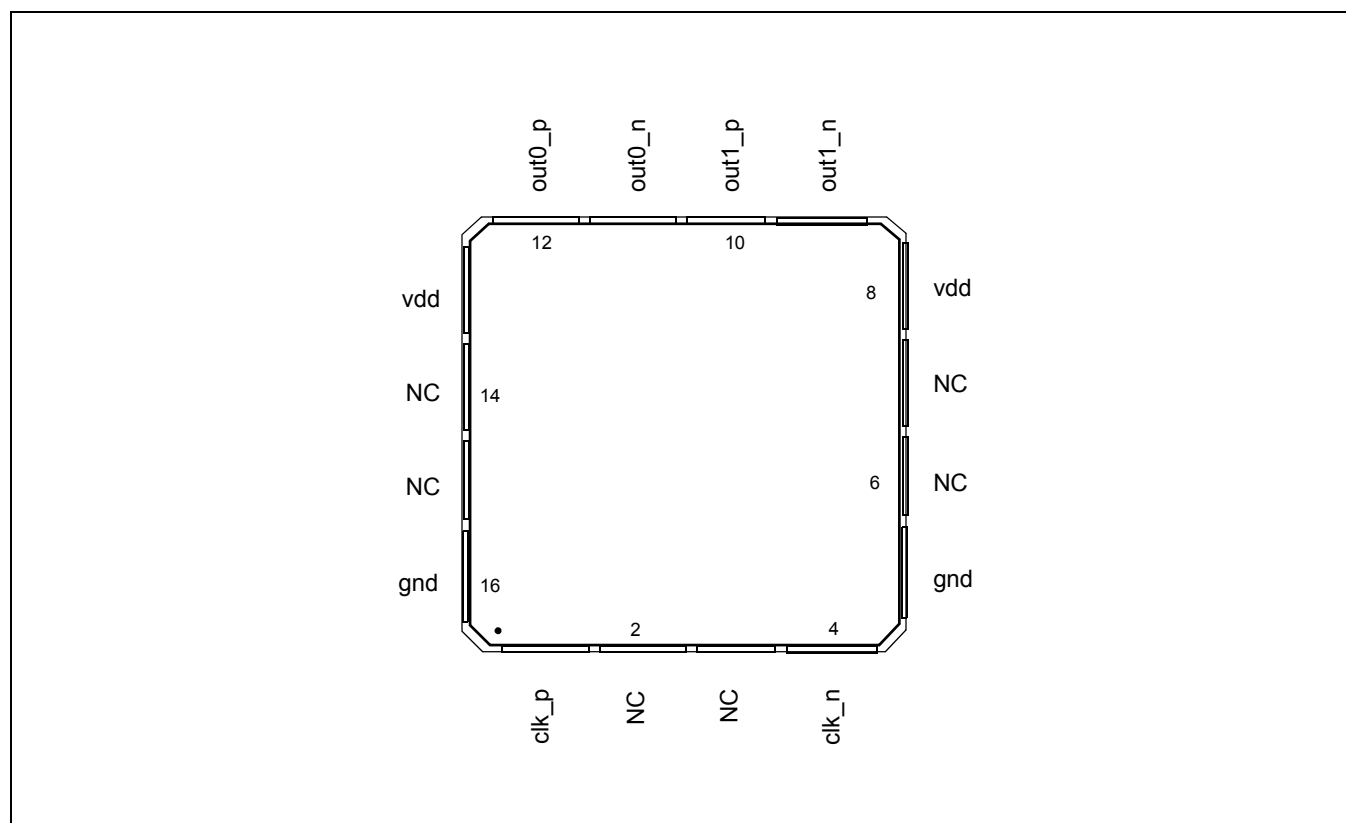

Figure 2 - Pin Connections

2.0 Pin Description

Pin Description

Pin #	Name	Description
1, 4	clk_p, clk_n,	Differential Input (Analog Input). Differential input signals.
12, 11, 10, 9	out0_p, out0_n out1_p, out1_n	Differential Output (Analog Output). Differential outputs.
8, 13	vdd	Positive Supply Voltage. 2.5V _{DC} or 3.3 V _{DC} nominal.
5, 16	gnd	Ground. 0 V.
2, 3, 6, 7, 14, 15	NC	No Connection. Leave unconnected.
Exposed Pad		Device GND.

3.0 Functional Description

The ZL40200 is an LVPECL clock fanout buffer with two identical output clock drivers capable of operating at frequencies up to 750MHz.

Inputs to the ZL40200 are externally terminated to allow use of precision termination components and to allow full flexibility of input termination. The ZL40200 can accept DC coupled LVPECL or LVDS and AC coupled LVPECL, LVDS, CML or HCSL input signals; single ended input signals can also be accepted. A pin compatible device with internal termination is also available.

The ZL40200 is designed to fan out low-jitter reference clocks for wired or optical communications applications while adding minimal jitter to the clock signal. An internal linear power supply regulator and bulk capacitors minimize additive jitter due to power supply noise. The device operates from 2.5V \pm 5% or 3.3V \pm 5% supply. Its operation is guaranteed over the industrial temperature range -40°C to +85°C.

The device block diagram is shown in Figure 1; its operation is described in the following sections.

3.1 Clock Inputs

The device can accept LVPECL, LVDS, CML, HCSL and single-ended inputs.

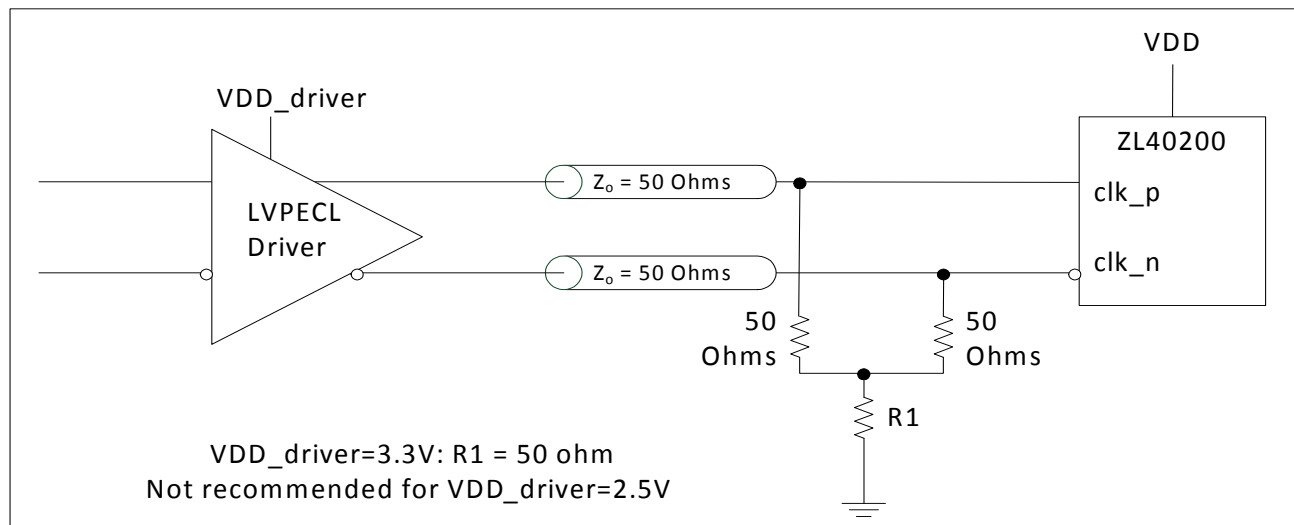

Figure 3 - LVPECL Input DC Coupled Thevenin Equivalent

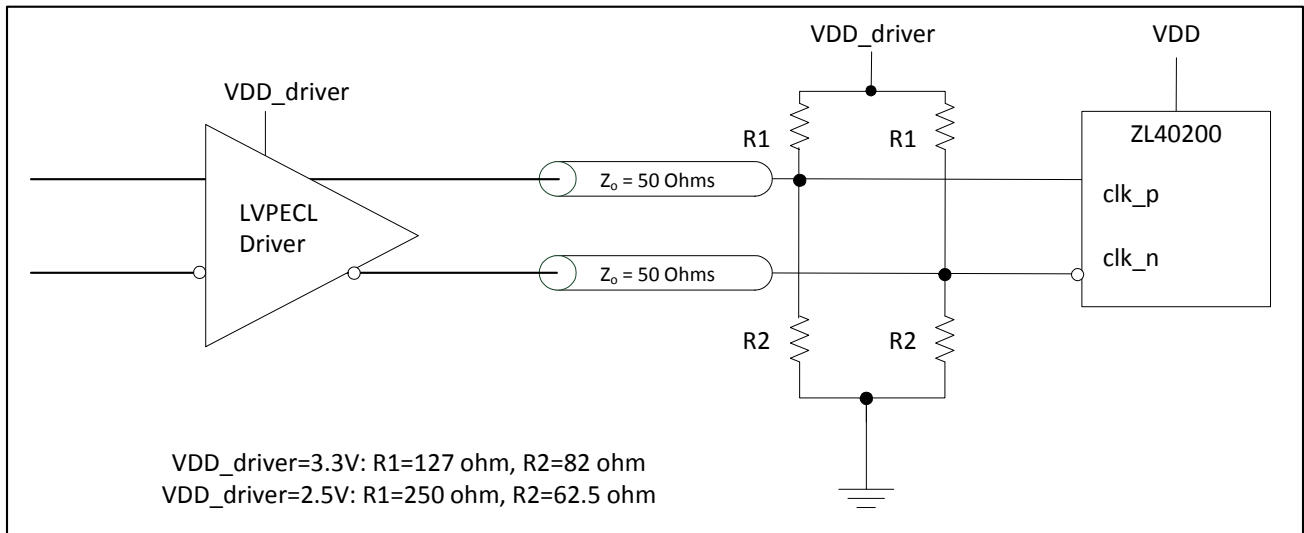

Figure 4 - LVPECL Input DC Coupled Parallel Termination

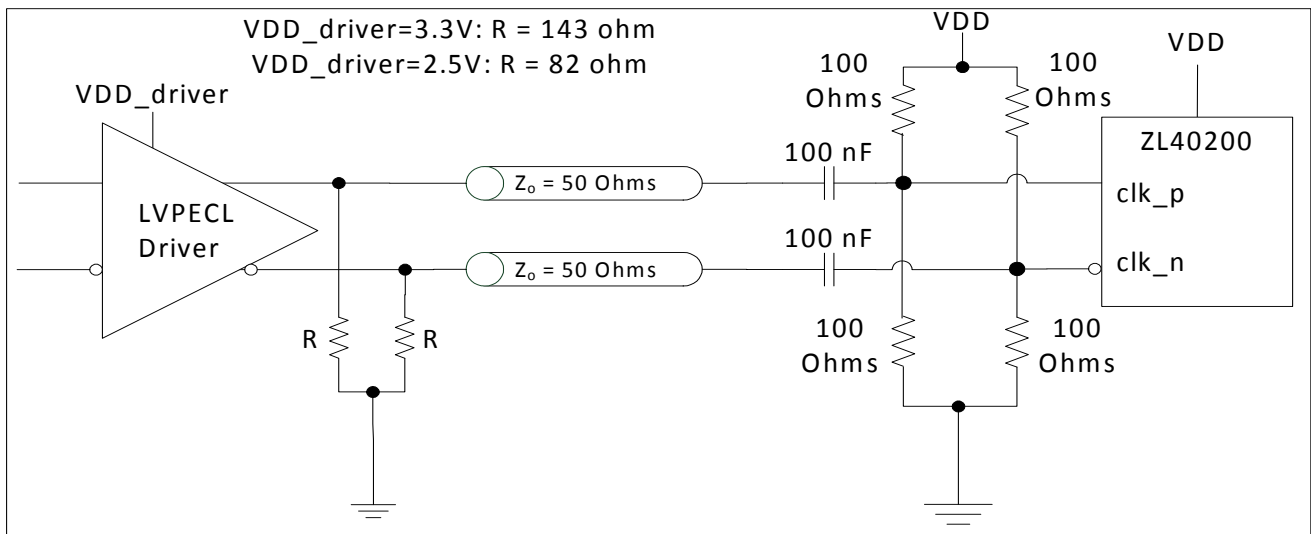

Figure 5 - LVPECL Input AC Coupled Termination

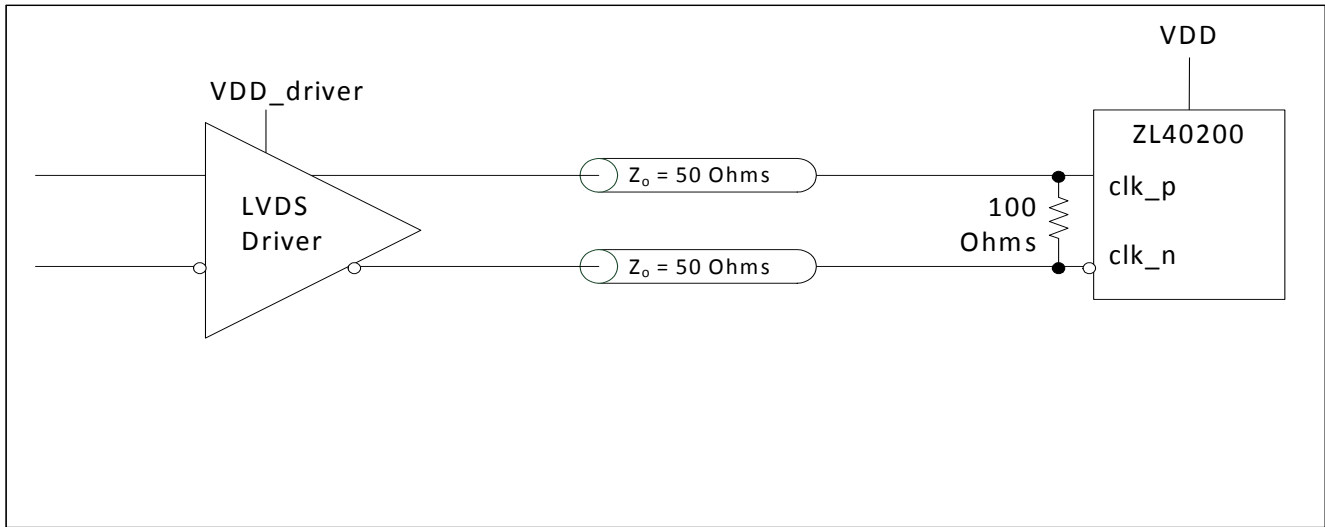

Figure 6 - LVDS Input DC Coupled

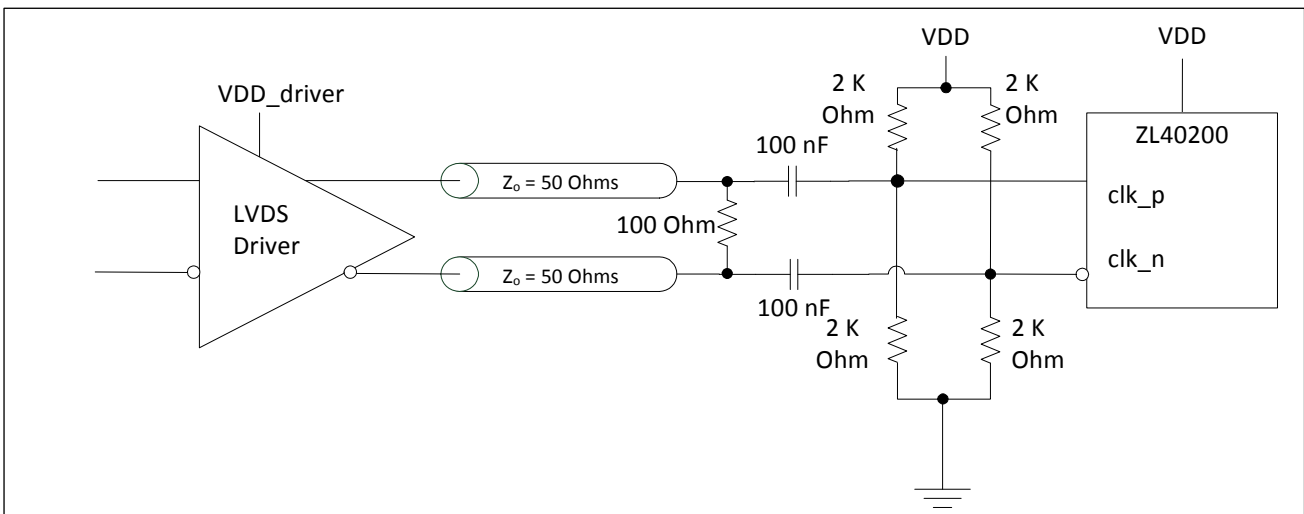

Figure 7 - LVDS Input AC Coupled

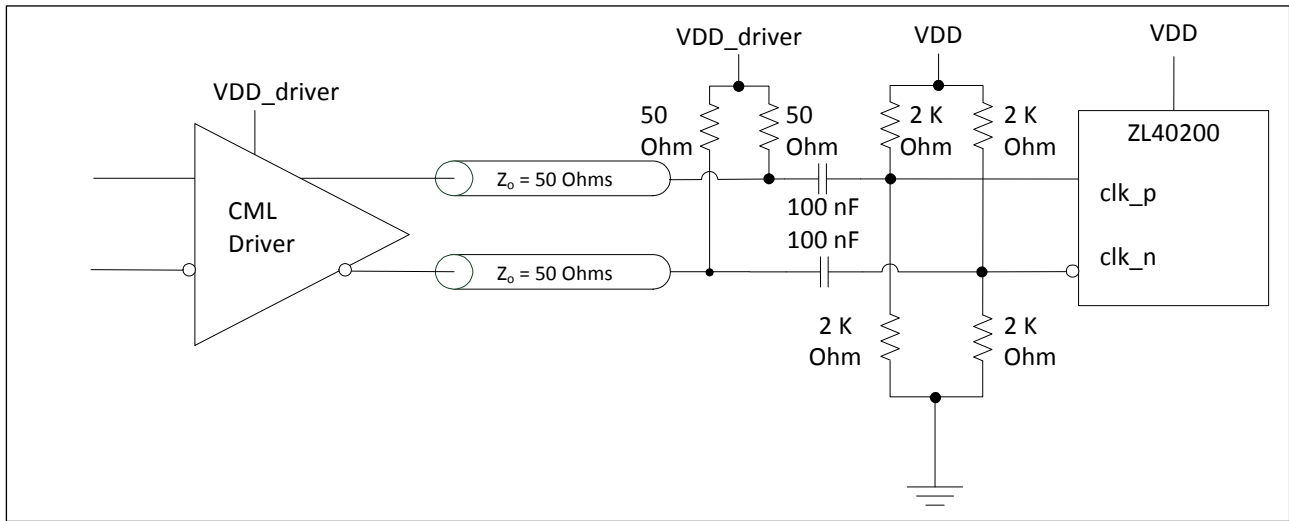

Figure 8 - CML Input AC Coupled

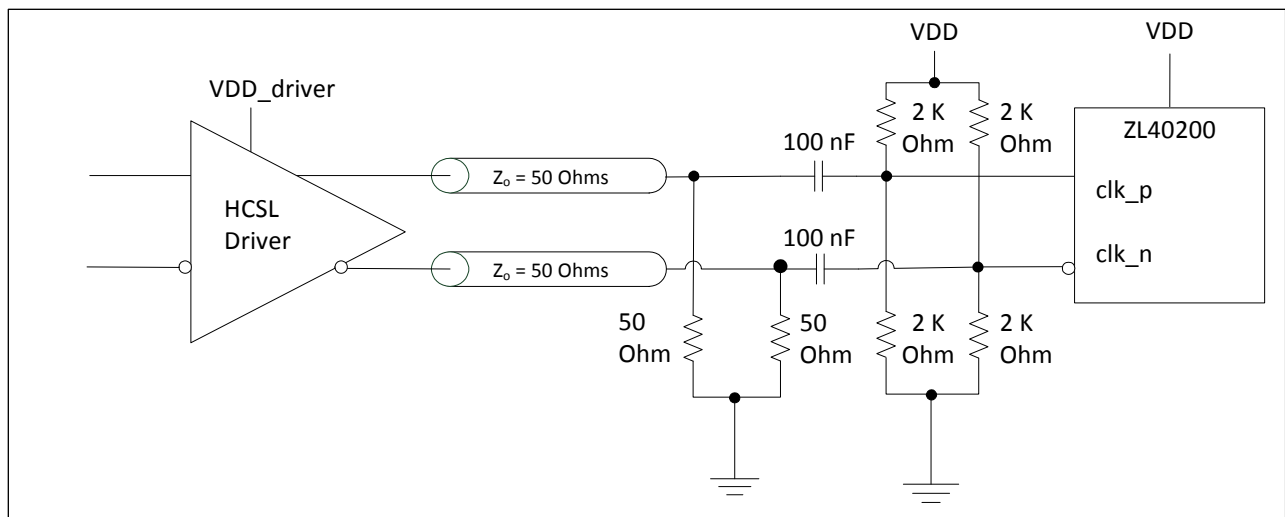

Figure 9 - HCSL Input AC Coupled

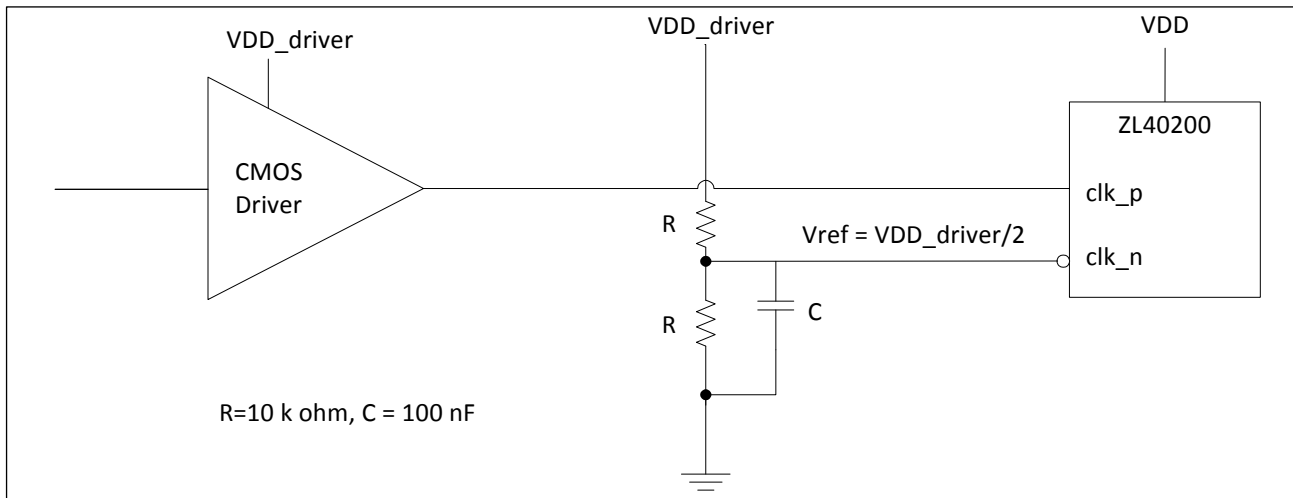

Figure 10 - CMOS Input DC Coupled Referenced to VDD/2

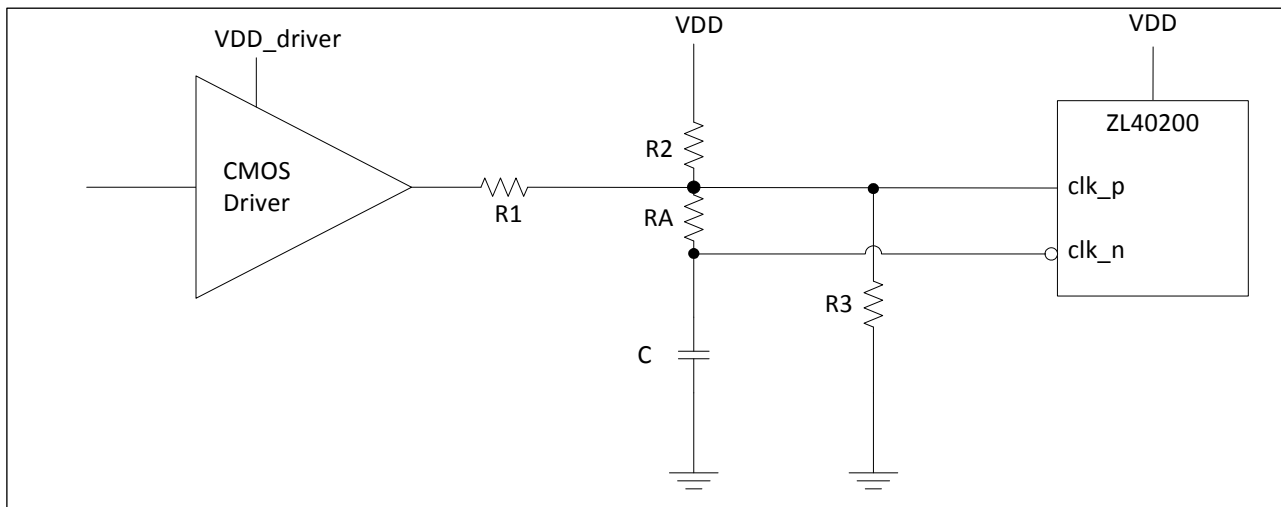

Figure 11 - CMOS Input DC Coupled Referenced to Ground

VDD_driver	R1 (kΩ)	R2 (kΩ)	R3 (kΩ)	RA (kΩ)	C (pF)
1.5	1.25	3.075	open	10	10
1.8	1	3.8	open	10	10
2.5	0.33	4.2	open	10	10
3.3	0.75	open	4.2	10	10

Table 1 - Component Values for Single Ended Input Reference to Ground

* For frequencies below 100 MHz, increase C to avoid signal integrity issues.

3.2 Clock Outputs

LVPECL has a very low output impedance and a differential signal swing between 1V and 1.6 V. A simplified diagram for the output stage is shown in Figure 12. The LVPECL to LVDS output termination is not shown since there is a separate device that has the same input and LVDS outputs.

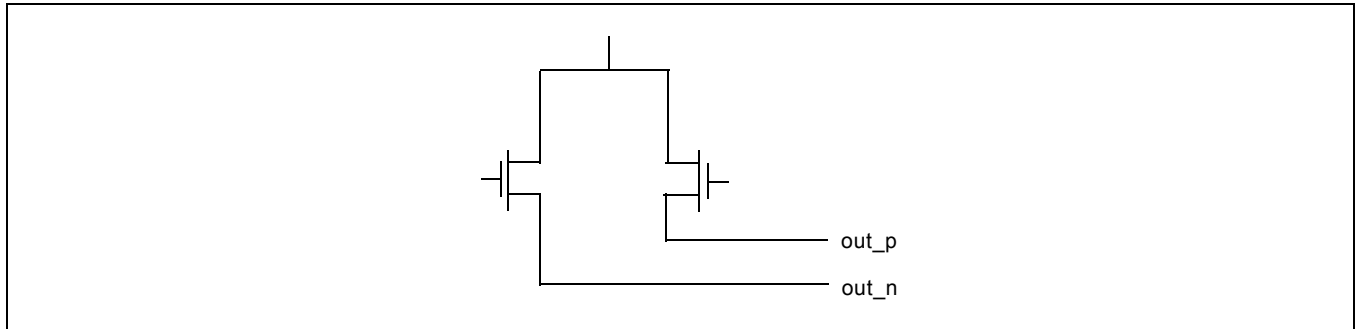

Figure 12 - Simplified Output Driver

The methods to terminate the ZL40200 LVPECL drivers are shown in the following figures.

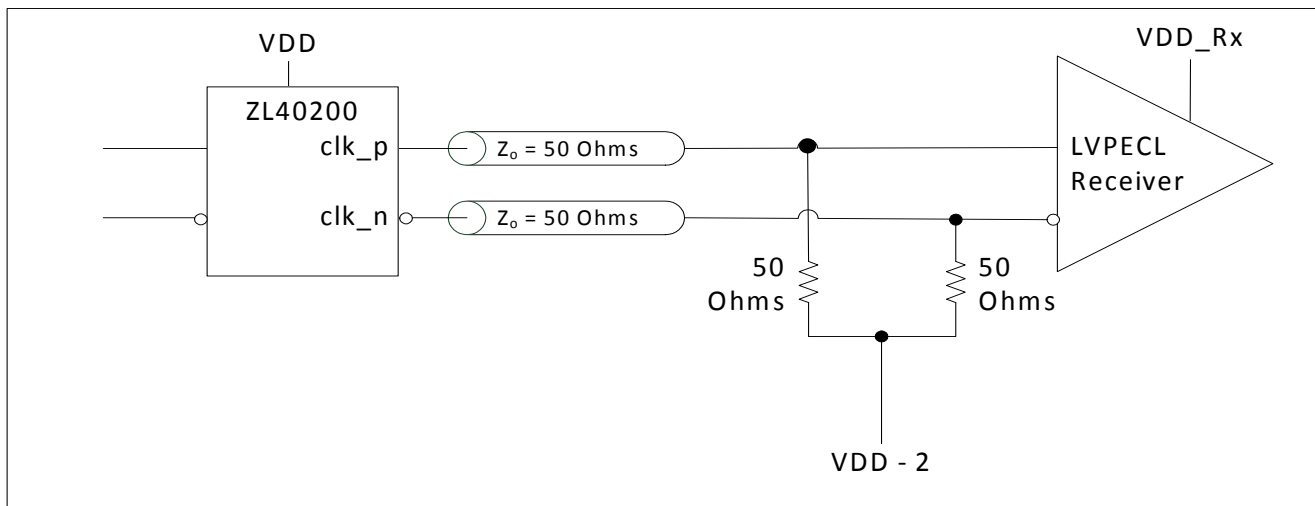

Figure 13 - LVPECL Basic Output Termination

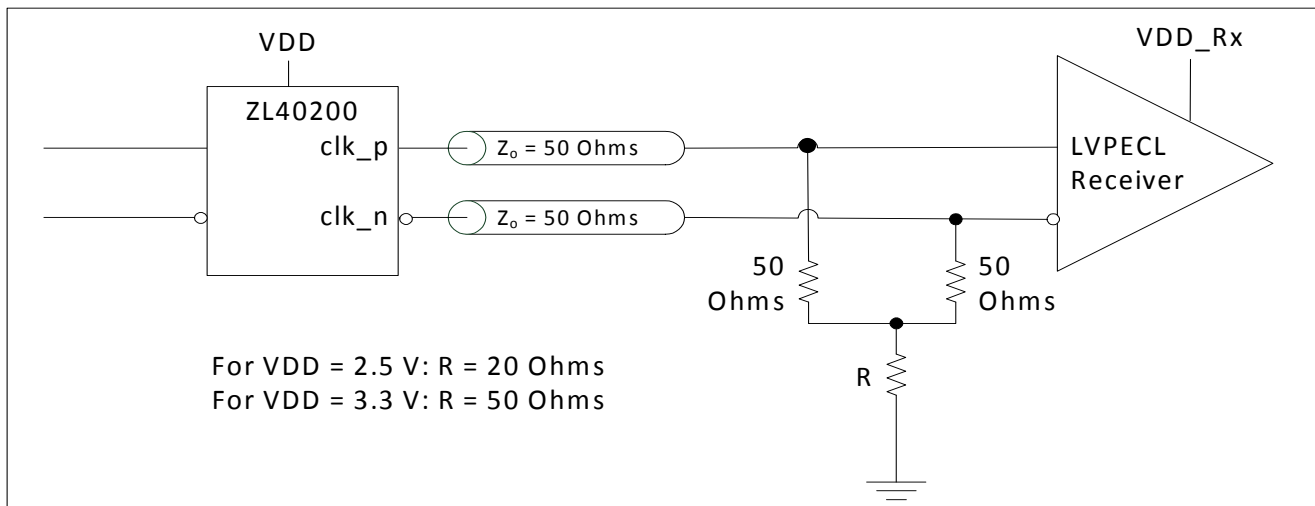

Figure 14 - LVPECL Parallel Output Termination

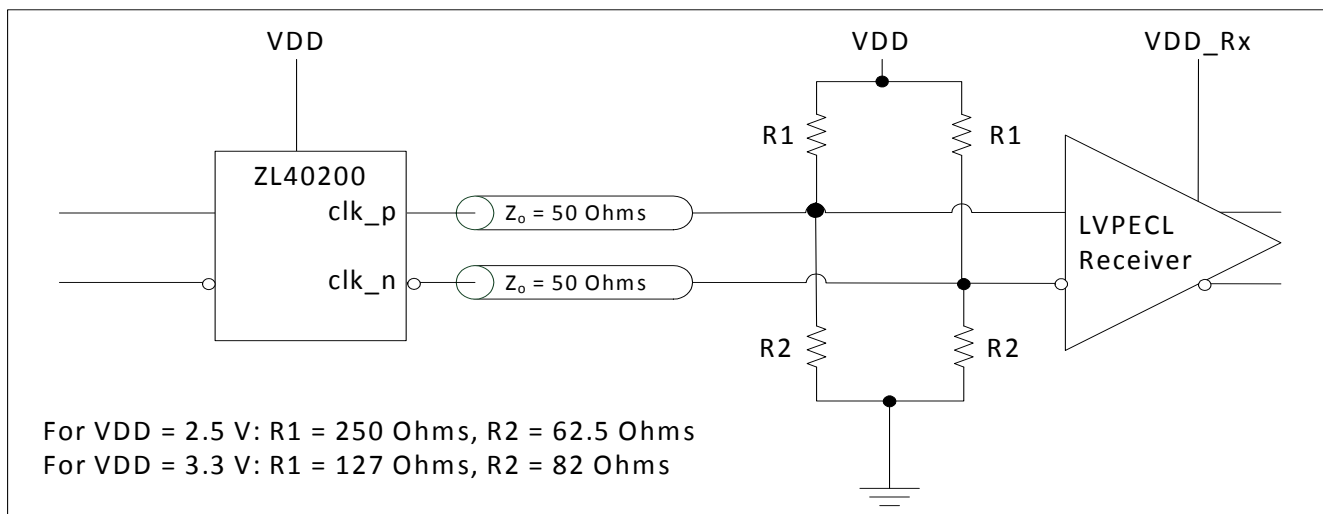

Figure 15 - LVPECL Parallel Thevenin-Equivalent Output Termination

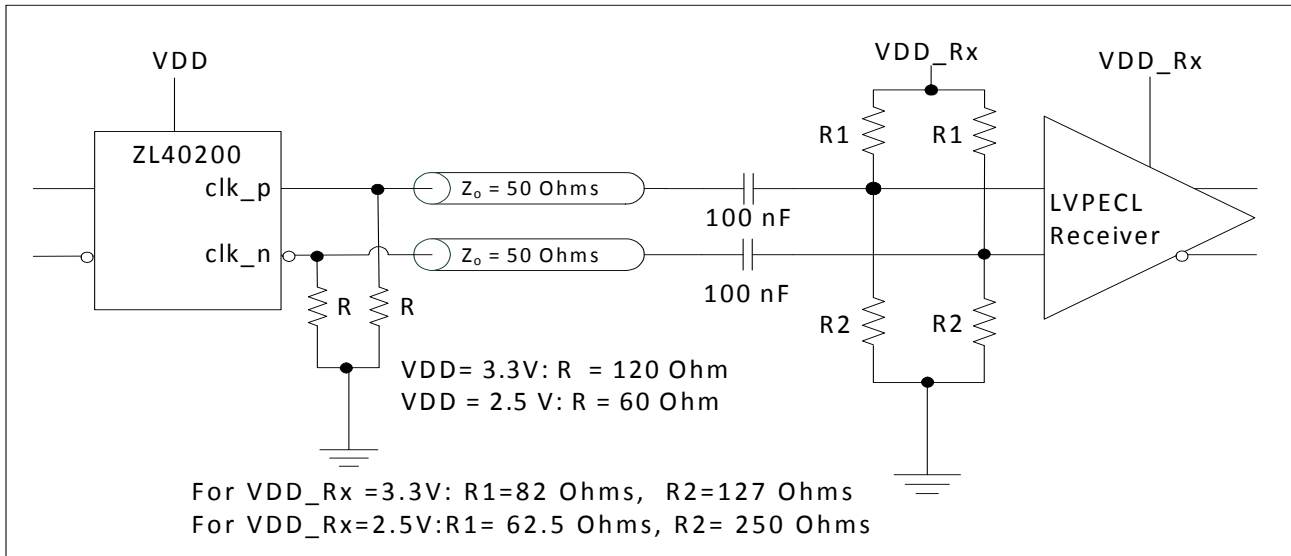

Figure 16 - LVPECL AC Output Termination for Externally Terminated LVPECL Inputs

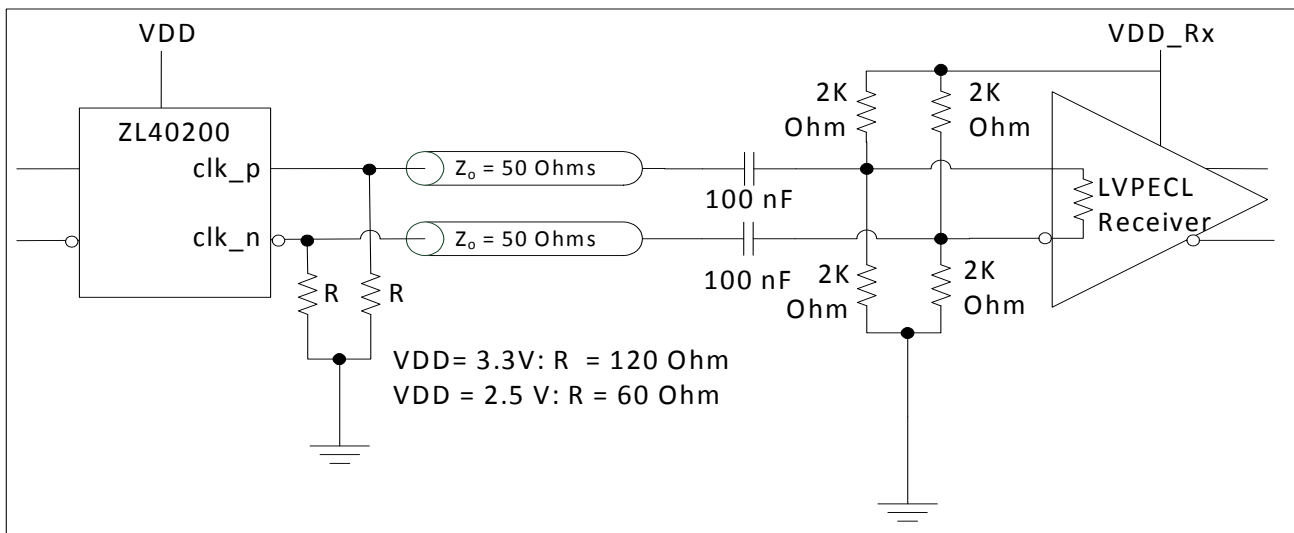

Figure 17 - LVPECL AC Output Termination for Internally Terminated LVPECL Inputs

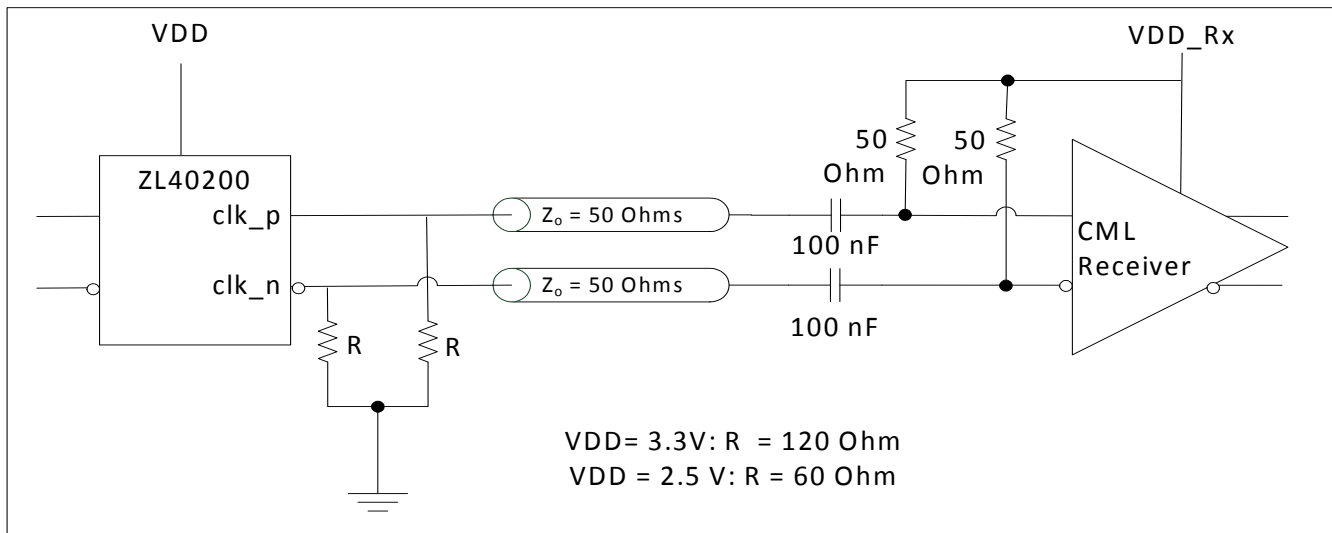

Figure 18 - LVPECL AC-Coupled Output Termination for CML Inputs

3.3 Device Additive Jitter

The ZL40200 clock fan out buffer is not intended to filter clock jitter. The jitter performance of this type of device is characterized by its additive jitter. Additive jitter is the jitter the device would add to a hypothetical jitter-free clock as it passes through the device. The additive jitter of the ZL40200 is random and as such it is not correlated to the jitter of the input clock signal.

The square of the resultant random RMS jitter at the output of the ZL40200 is equal to the sum of the squares of the various random RMS jitter sources including: input clock jitter; additive jitter of the buffer; and additive jitter due to power supply noise. There may be additional deterministic jitter sources that are not shown in Figure 19.

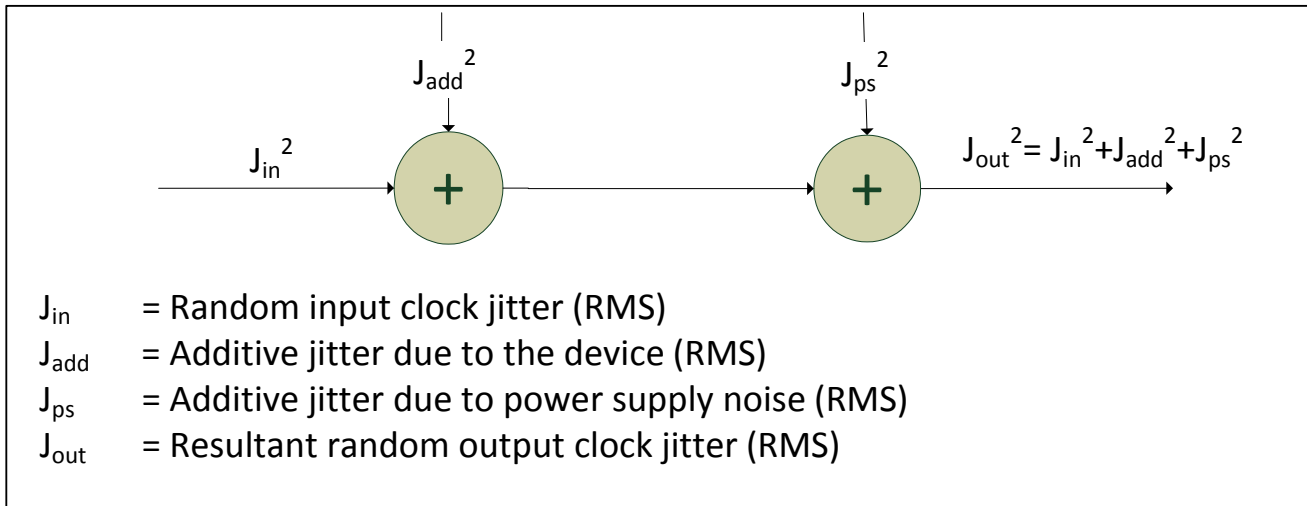

Figure 19 - Additive Jitter

3.4 Power Supply

This device operates with either a 2.5V supply or 3.3V supply.

3.4.1 Sensitivity to power supply noise

Power supply noise from sources such as switching power supplies and high-power digital components such as FPGAs can induce additive jitter on clock buffer outputs. The ZL40200 is equipped with a low drop out (LDO) power regulator and on-chip bulk capacitors to minimize additive jitter due to power supply noise. The LDO regulator on the ZL40200 allows this device to have superior performance even in the presence of external noise sources. The on-chip regulation, recommended power supply filtering, and good PCB layout all work together to minimize the additive jitter from power supply noise.

The performance of these clock buffers in the presence of power supply noise is detailed in ZLAN-403, "Power Supply Rejection in Clock Buffers" which is available from Applications Engineering.

3.4.2 Power supply filtering

For optimal jitter performance, the device should be isolated from the power planes connected to its power supply pins as shown in Figure 20.

- 10 μF capacitors should be size 0603 or size 0805 X5R or X7R ceramic, 6.3 V minimum rating
- 0.1 μF capacitors should be size 0402 X5R ceramic, 6.3 V minimum rating
- Capacitors should be placed next to the connected device power pins
- a 0.3 Ohm resistor is recommended for the filter shown in Figure 20

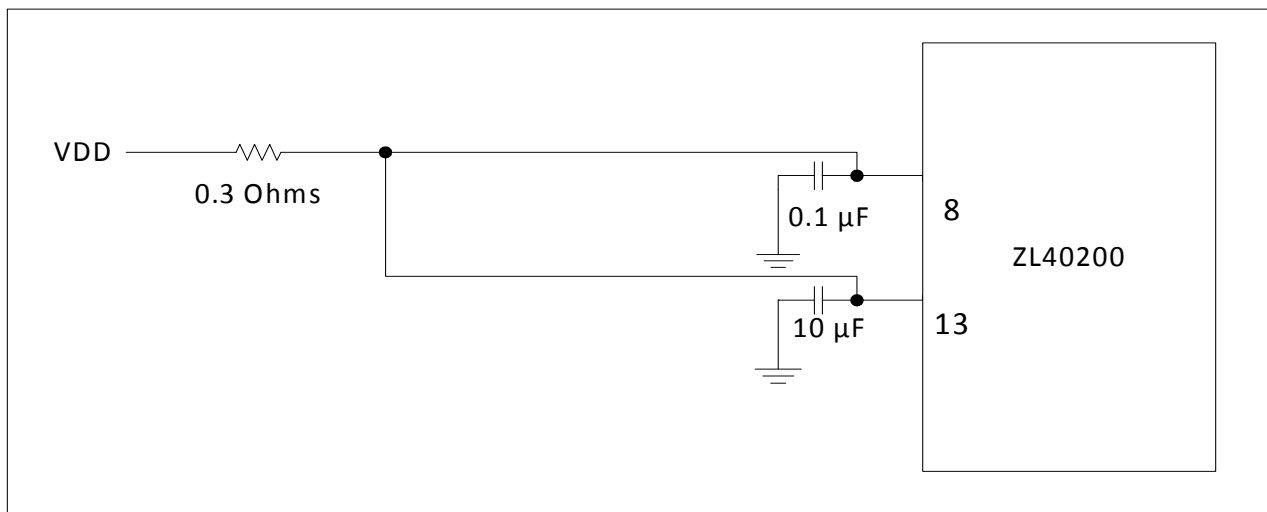

Figure 20 - Decoupling Connections for Power Pins

3.4.3 PCB layout considerations

The power nets in Figure 20 can be implemented either as a plane island or routed power topology without changing the overall jitter performance of the device.

4.0 AC and DC Electrical Characteristics

Absolute Maximum Ratings*

	Parameter	Sym.	Min.	Max.	Units
1	Supply voltage	V_{DD_R}	-0.5	4.6	V
2	Voltage on any digital pin	V_{PIN}	-0.5	V_{DD}	V
3	LVPECL output current	I_{out}		30	mA
4	Soldering temperature	T		260	°C
5	Storage temperature	T_{ST}	-55	125	°C
6	Junction temperature	T_j		125	°C
7	Voltage on input pin	V_{input}		V_{DD}	V
8	Input capacitance each pin	C_p		500	fF

* Exceeding these values may cause permanent damage. Functional operation under these conditions is not implied.

* Voltages are with respect to ground (GND) unless otherwise stated

Recommended Operating Conditions*

	Characteristics	Sym.	Min.	Typ.	Max.	Units
1	Supply voltage 2.5 V mode	V_{DD25}	2.375	2.5	2.625	V
2	Supply voltage 3.3 V mode	V_{DD33}	3.135	3.3	3.465	V
3	Operating temperature	T_A	-40	25	85	°C

* Voltages are with respect to ground (GND) unless otherwise stated

DC Electrical Characteristics - Current Consumption

	Characteristics	Sym.	Min.	Typ.	Max.	Units	Notes
1	Supply current LVPECL drivers - unloaded	I_{dd_unload}		49		mA	Unloaded
2	Supply current LVPECL drivers - loaded (all outputs are active)	I_{dd_load}		88		mA	Including power to $R_L = 50\Omega$

DC Electrical Characteristics - Inputs and Outputs - for 3.3 V Supply

	Characteristics	Sym.	Min.	Typ.	Max.	Units	Notes
1	Differential input common mode voltage	V_{CM}	1.1		2.0	V	
2	Differential input voltage difference	V_{ID}	0.25		1	V	
3	LVPECL output high voltage	V_{OH}	V_{DD}^- 1.40			V	Measured at 10 MHz
4	LVPECL output low voltage	V_{OL}			V_{DD}^- 1.62	V	Measured at 10 MHz

DC Electrical Characteristics - Inputs and Outputs - for 3.3 V Supply

	Characteristics	Sym.	Min.	Typ.	Max.	Units	Notes
5	LVPECL output differential voltage	V_{OD}	0.5		0.9	V	

* The VOD parameter was measured from 125 MHz to 750 MHz.

DC Electrical Characteristics - Inputs and Outputs - for 2.5 V Supply

	Characteristics	Sym.	Min.	Typ.	Max.	Units	Notes
1	Differential input common mode voltage	V_{CM}	1.1		1.6	V	
2	Differential input voltage difference	V_{ID}	0.25		1	V	
3	LVPECL output high voltage	V_{OH}	$V_{DD} - 1.40$			V	
4	LVPECL output low voltage	V_{OL}			$V_{DD} - 1.62$	V	
5	LVPECL output differential voltage*	V_{OD}	0.4		0.9	V	

* The VOD parameter was measured from 125 MHz to 750 MHz.

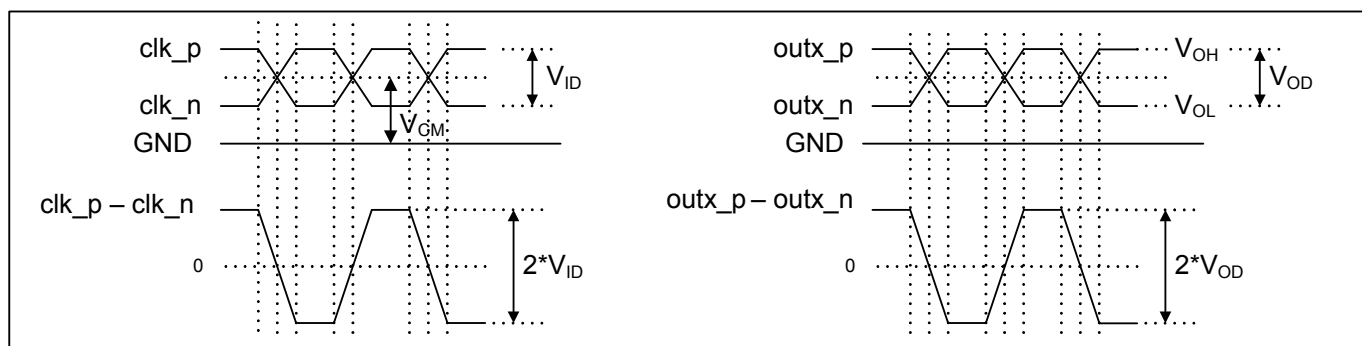

Figure 21 - Differential Voltage Parameter

AC Electrical Characteristics* - Inputs and Outputs (see Figure 22) - for 3.3 V supply.

	Characteristics	Sym.	Min.	Typ.	Max.	Units	Notes
1	Maximum Operating Frequency	$1/t_p$			750	MHz	
2	input to output clock propagation delay	t_{pd}	0	1	2	ns	
3	output to output skew	$t_{out2out}$		50	100	ps	
4	part to part output skew	$t_{part2part}$		80	300	ps	
5	Output clock Duty Cycle degradation	t_{PWH}/t_{PWL}	-2%	0%	2%	Duty Cycle	
6	LVPECL Output Slew Rate	r_{sk}	0.75	1.2		V/ns	

* Supply voltage and operating temperature are as per Recommended Operating Conditions

AC Electrical Characteristics* - Inputs and Outputs (see Figure 22) - for 2.5 V supply.

	Characteristics	Sym.	Min.	Typ.	Max.	Units	Notes
1	Maximum Operating Frequency	$1/t_p$			750	MHz	
2	input to output clock propagation delay	t_{pd}	0	1	2	ns	
3	output to output skew	$t_{out2out}$		50	100	ps	
4	part to part output skew	$t_{part2part}$		80	300	ps	
5	Output clock Duty Cycle degradation	t_{PWH}/t_{PWL}	-2	0	2	Percent	
6	LVPECL Output Slew Rate	r_{sk}	0.75	1.2		ps	

* Supply voltage and operating temperature are as per Recommended Operating Conditions

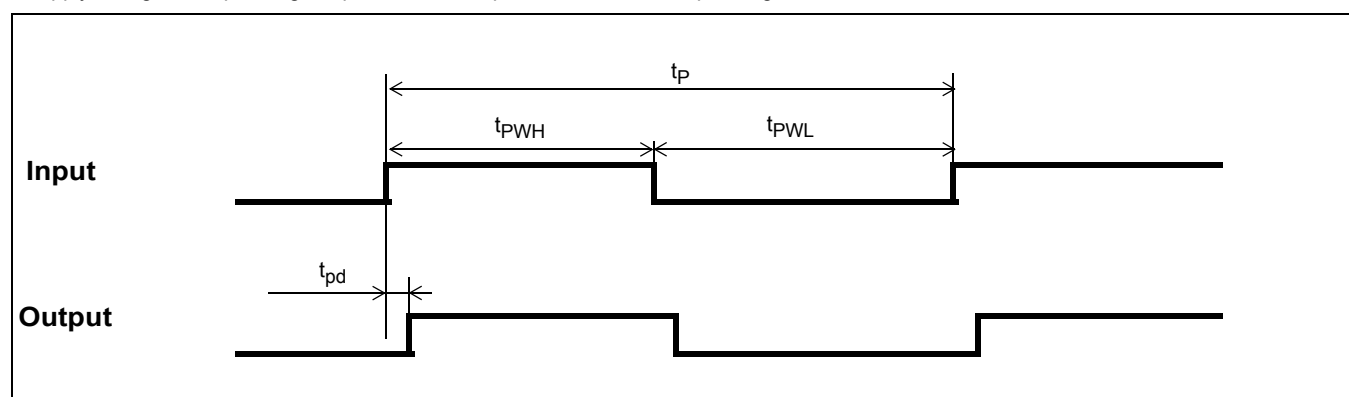

Figure 22 - Input To Output Timing

5.0 Performance Characterization

Additive Jitter at 2.5 V*

	Output Frequency (MHz)	Jitter Measurement Filter	Typical RMS (fs)	Notes
1	125	12 kHz - 20 MHz	112	
2	212.5	12 kHz - 20 MHz	80	
3	311.04	12 kHz - 20 MHz	70	
4	425	12 kHz - 20 MHz	65	
5	500	12 kHz - 20 MHz	56	
6	622.08	12 kHz - 20 MHz	43	
7	750	12 kHz - 20 MHz	39	

*The values in this table were taken with an approximate slew rate of 0.8 V/ns.

Additive Jitter at 3.3 V*

	Output Frequency (MHz)	Jitter Measurement Filter	Typical RMS (fs)	Notes
1	125	12 kHz - 20 MHz	112	
2	212.5	12 kHz - 20 MHz	82	
3	311.04	12 kHz - 20 MHz	72	
4	425	12 kHz - 20 MHz	63	
5	500	12 kHz - 20 MHz	52	
6	622.08	12 kHz - 20 MHz	43	
7	750	12 kHz - 20 MHz	39	

*The values in this table were taken with an approximate slew rate of 0.8 V/ns.

Additive Jitter from a Power Supply Tone*

Carrier Frequency (MHz)	Parameter	Typical	Units	Notes
125MHz	25 mV at 100 kHz	159	fs RMS	
750MHz	25 mV at 100 kHz	82	fs RMS	

* The values in this table are the additive periodic jitter caused by an interfering tone typically caused by a switching power supply. For this test, measurements were taken over the full temperature and voltage range for $V_{DD} = 3.3$ V. The magnitude of the interfering tone is measured at the DUT.

6.0 Typical Behavior

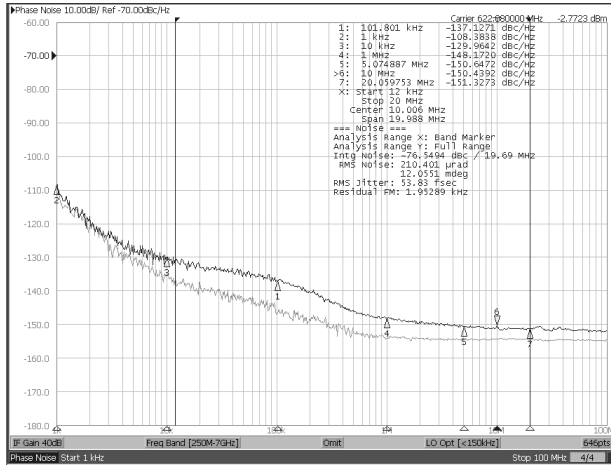

Typical Phase Noise at 622.08 MHz

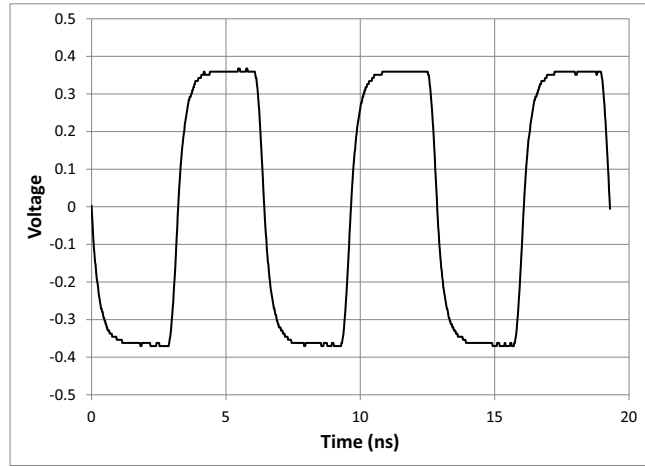

Typical Waveform at 155.52 MHz

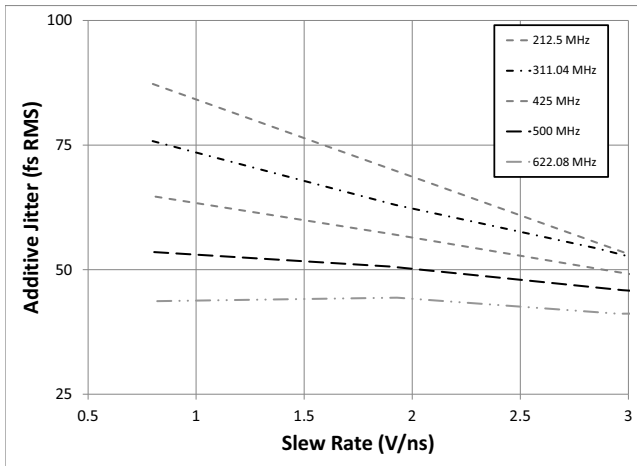

Input Slew Rate versus Additive Jitter

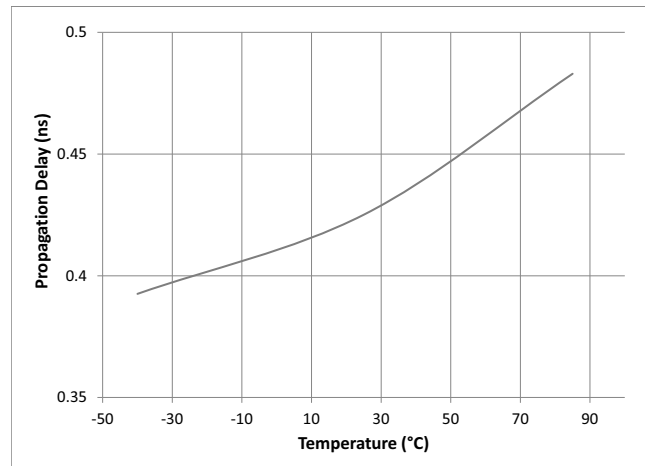

Propagation Delay versus Temperature

Note: This is for a single device. For more details see the characterization section.

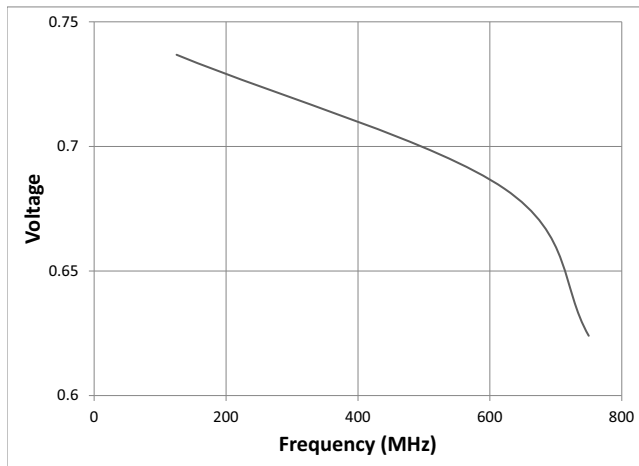

V_{OD} versus Frequency

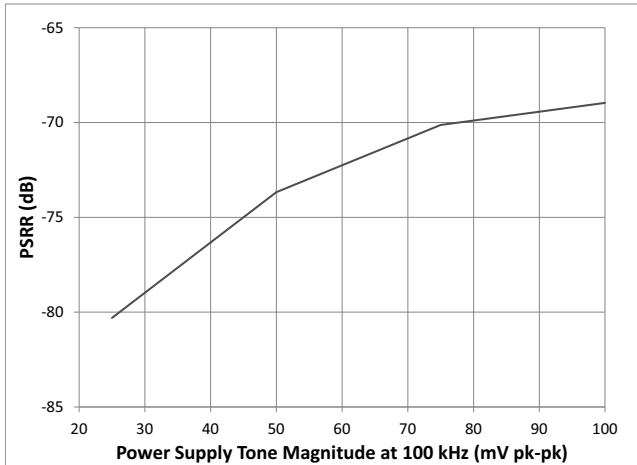

Power Supply Tone Magnitude versus PSRR (at 100 kHz) at 125 MHz

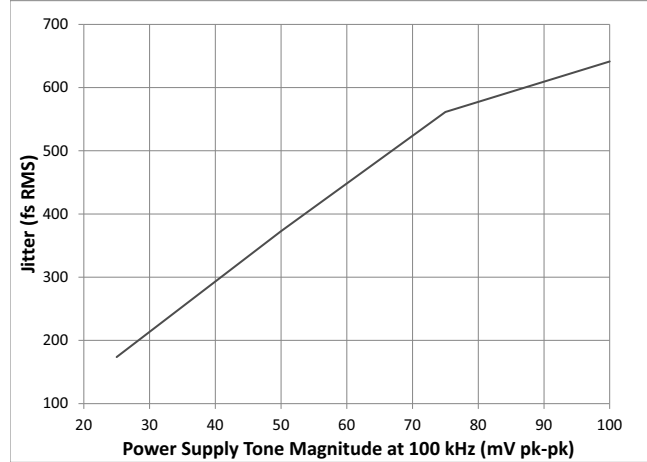

Power Supply Tone Magnitude versus Additive Jitter (at 100 kHz) at 125 MHz

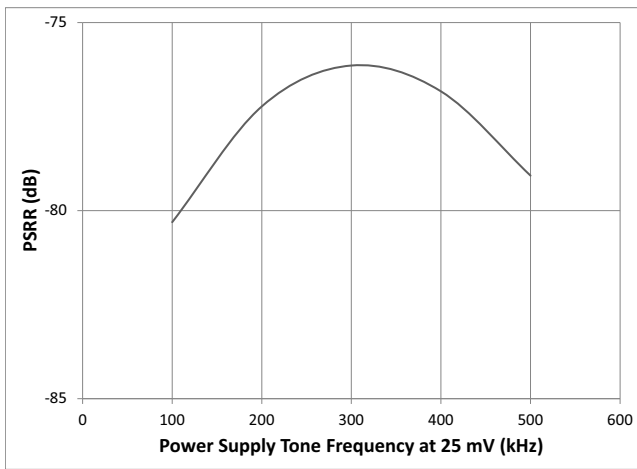

Power Supply Tone Frequency (at 25 mV) versus PSRR at 125 MHz

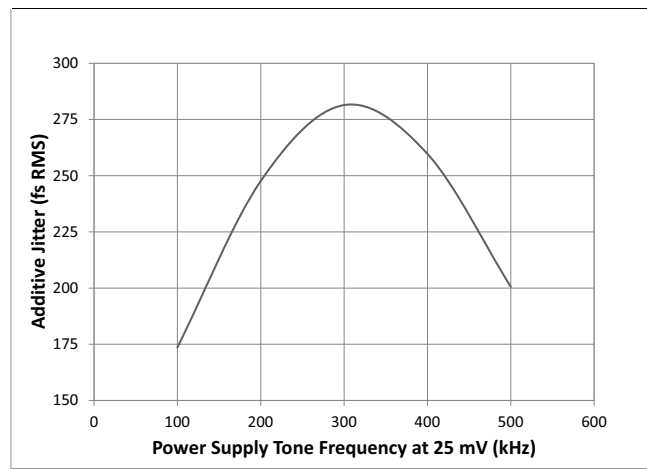

Power Supply Tone Frequency (at 25 mV) versus Additive Jitter at 125 MHz

7.0 Package Thermal Characteristics

Thermal Data

Parameter	Symbol	Test Condition	Value	Unit
Junction to Ambient Thermal Resistance	Θ_{JA}	Still Air	67.9	$^{\circ}\text{C}/\text{W}$
		1 m/s	61.6	
		2 m/s	58.1	
Junction to Case Thermal Resistance	Θ_{JC}	Still Air	44.1	$^{\circ}\text{C}/\text{W}$
Junction to Board Thermal Resistance	Θ_{JB}	Still Air	23.2	$^{\circ}\text{C}/\text{W}$
Maximum Junction Temperature*	T_{jmax}		125	$^{\circ}\text{C}$
Maximum Ambient Temperature	T_A		85	$^{\circ}\text{C}$

* Proper thermal management must be practiced to ensure that T_{jmax} is not exceeded.

8.0 Mechanical Drawing

