

Features

Inputs/Outputs

- Accepts two differential or single-ended inputs
 - LVPECL, LVDS, CML, HCSL, LVCMOS
 - Glitch-free switching of references
- Six precision LVPECL outputs
- Operating frequency up to 750 MHz

Power

- Options for 2.5 V or 3.3 V power supply
- Core current consumption of 110 mA
- On-chip Low Drop Out (LDO) Regulator for superior power supply rejection

Performance

- Ultra low additive jitter of 121 fs RMS

Ordering Information

ZL40208LDG1	32 Pin QFN	Trays
ZL40208LDF1	32 Pin QFN	Tape and Reel
Matte Tin		
Package size: 5 x 5 mm		
-40°C to +85°C		

Applications

- General purpose clock distribution
- Low jitter clock trees
- Logic translation
- Clock and data signal restoration
- Redundant clock distribution
- Wired communications: OTN, SONET/SDH, GE, 10 GE, FC and 10G FC
- PCI Express generation 1/2/3 clock distribution
- Wireless communications
- High performance microprocessor clock distribution

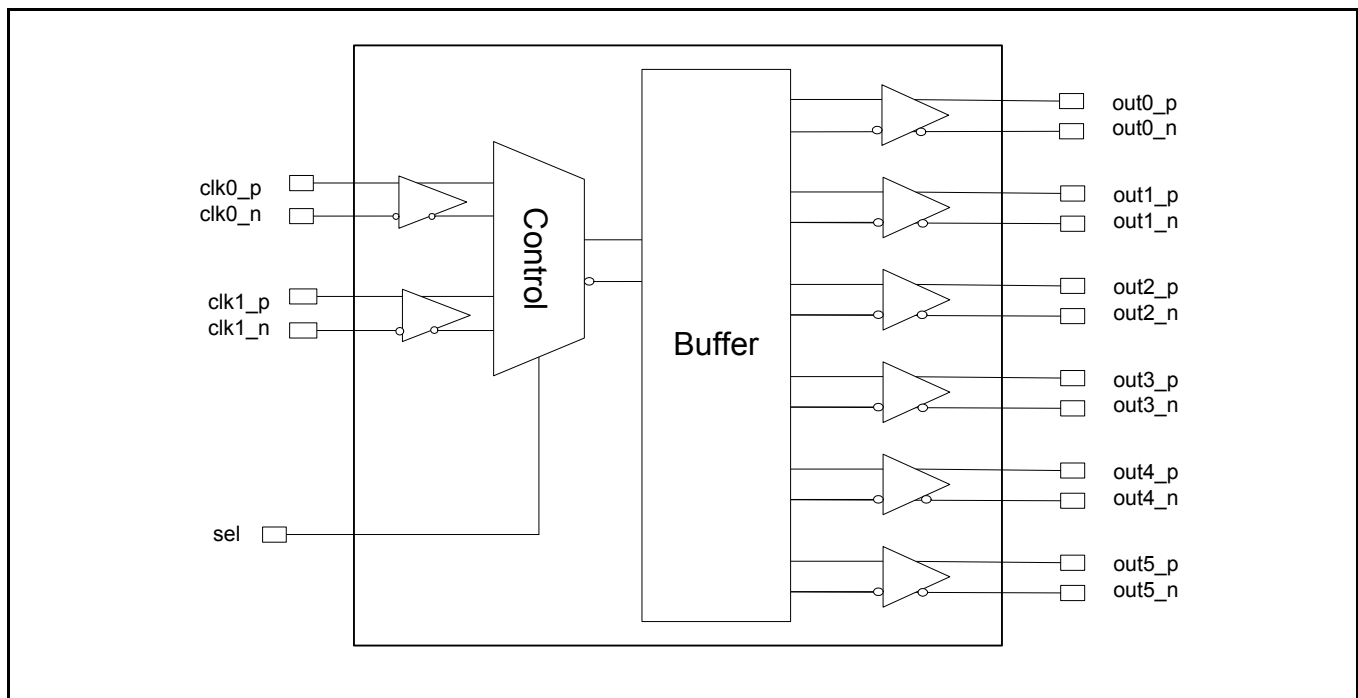

Figure 1 - Functional Block Diagram

Table of Contents

Features	1
Inputs/Outputs	1
Power	1
Performance	1
Applications	1
Change Summary	4
1.0 Package Description	5
2.0 Pin Description	6
3.0 Functional Description	7
3.1 Clock Inputs	7
3.1.1 Clock Input Selection	7
3.1.2 Clock Input Termination	8
3.2 Clock Outputs	13
3.3 Device Additive Jitter	17
3.4 Power Supply	18
3.4.1 Sensitivity to power supply noise	18
3.4.2 Power supply filtering	18
3.4.3 PCB layout considerations	18
4.0 AC and DC Electrical Characteristics	19
5.0 Performance Characterization	22
6.0 Typical Behavior	23
7.0 Package Characteristics	25
8.0 Mechanical Drawing	26

List of Figures

Figure 1 - Functional Block Diagram	1
Figure 2 - Pin Connections	5
Figure 3 - Output During Clock Switch - Both Clocks Running	7
Figure 4 - LVPECL Input DC Coupled Thevenin Equivalent	8
Figure 5 - LVPECL Input DC Coupled Parallel Termination	8
Figure 6 - LVPECL Input AC Coupled Termination	9
Figure 7 - LVDS Input DC Coupled	9
Figure 8 - LVDS Input AC Coupled	10
Figure 9 - CML Input AC Coupled	10
Figure 10 - HCSL Input AC Coupled	11
Figure 11 - CMOS Input DC Coupled Referenced to VDD/2	11
Figure 12 - CMOS Input DC Coupled Referenced to Ground	12
Figure 13 - Simplified Output Driver	13
Figure 14 - LVPECL Basic Output Termination	13
Figure 15 - LVPECL Parallel Output Termination	14
Figure 16 - LVPECL Parallel Thevenin-Equivalent Output Termination	14
Figure 17 - LVPECL AC Output Termination for Externally Terminated LVPECL Inputs	15
Figure 18 - LVPECL AC Output Termination for Internally Terminated LVPECL Inputs	15
Figure 19 - LVPECL AC Output Termination for CML Inputs	16
Figure 20 - Additive Jitter	17
Figure 21 - Decoupling Connections for Power Pins	18
Figure 22 - Differential Voltages Parameter	20
Figure 23 - Input To Output Timing	21

Change Summary

Below are the changes from the February 2013 issue to the April 2014 issue:

Page	Item	Change
1	Applications	Added PCI Express clock distribution.
6	Pin Description	Added exposed pad to Pin Description.
8	Figure 4 and Figure 5	Removed 22 Ohm series resistors from Figure 3 and 4. These resistors are not required; however, there is no impact to performance if the resistors are included.
15	Figure 17	Corrected LVPECL interface circuit.
20	Figure 22	Clarification of V_{ID} and V_{OD} .

Below are the changes from the November 2012 issue to the February 2013 issue:

Page	Item	Change
8	Figure 5	Changed text to indicate the circuit is not recommended for $VDD_driver=2.5V$.
9	Figure 6	Changed pull-up and pull-down resistors from 2kOhm to 100Ohm.

1.0 Package Description

The device is packaged in a 32 pin QFN

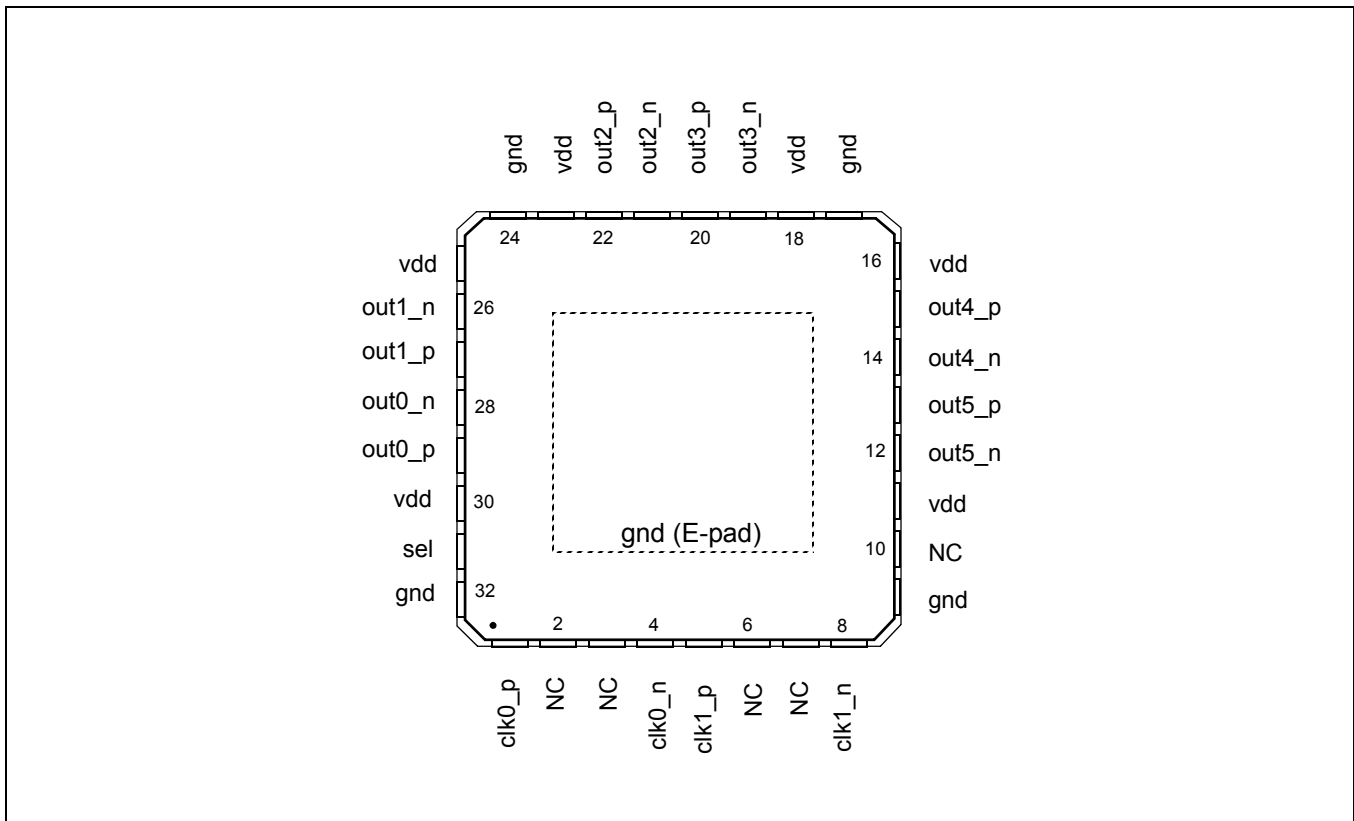

Figure 2 - Pin Connections

2.0 Pin Description

Pin #	Name	Description
1, 4, 5, 8	clk0_p, clk0_n, clk1_p, clk1_n	Differential Input (Analog Input). Differential (or singled ended) input signals. For all input signal configuration see Section 3.1, "Clock Inputs".
29, 28, 27, 26, 22, 21, 20, 19, 15, 14, 13, 12	out0_p, out0_n out1_p, out1_n out2_p, out2_n out3_p, out3_n out4_p, out4_n out5_p, out5_n	Differential Output (Analog Output). Differential outputs.
11, 16, 18, 23, 25, 30	vdd	Positive Supply Voltage. 2.5V _{DC} or 3.3 V _{DC} nominal.
9, 17, 24, 32	gnd	Ground. 0 V.
31	sel	Input Select (Input). Selects the reference input that is buffered; 0: clk0 1: clk1 This pin is internally pulled down to GND.
2, 3, 6, 7, 10	NC	No Connection. Leave unconnected.
Exposed Pad		Device GND.

3.0 Functional Description

The ZL40208 is an LVPECL clock fanout buffer with six output clock drivers capable of operating at frequencies up to 750MHz.

The ZL40208 is designed to fan out low-jitter reference clocks for wired or optical communications applications while adding minimal jitter to the clock signal. An internal linear power supply regulator and bulk capacitors minimize additive jitter due to power supply noise. The device operates from 2.5V \pm 5% or 3.3V \pm 5% supply. Its operation is guaranteed over the industrial temperature range -40°C to +85°C.

The device block diagram is shown in Figure 1; its operation is described in the following sections.

3.1 Clock Inputs

Inputs to the ZL40208 are externally terminated to allow use of precision termination components and to allow full flexibility of input termination. The ZL40208 can accept DC coupled LVPECL or LVDS and AC coupled LVPECL, LVDS, CML or HCSL input signals; single ended input signals can also be accepted. A pin compatible device with internal termination is also available.

3.1.1 Clock Input Selection

The select line chooses which input clock is routed to the outputs.

Sel	Active Input
0	clk0
1	clk1

Table 1 - Input Selection

The following figure shows the expected clock switching performance. The output stops at the first falling edge of the initial clock after the select pin changes state. During switching there will be a short time when the output clock is not toggling. After this delay, the output will start toggling again with a rising edge of the newly selected clock. This behavior is independent of the frequencies of the input clocks. For instance, the two clocks could be at different frequencies and the behavior would still be consistent with this figure.

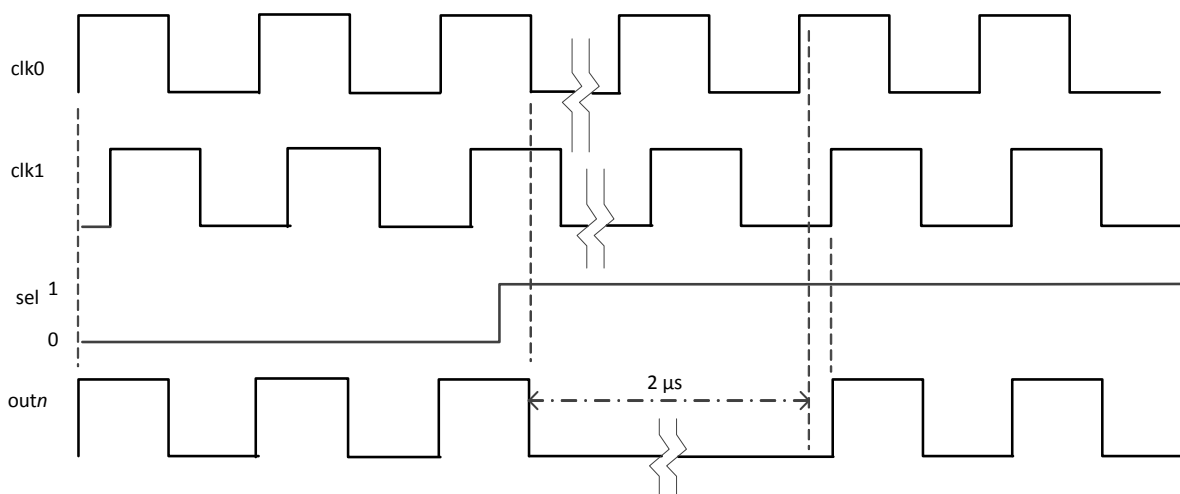

Figure 3 - Output During Clock Switch - Both Clocks Running

3.1.2 Clock Input Termination

The ZL40208 is adaptable to support different types of differential and single-ended input signals depending on the passive components used in the input termination. The application diagrams in the following figures allow the ZL40208 to accept LVPECL, LVDS, CML, HCSL and single-ended inputs.

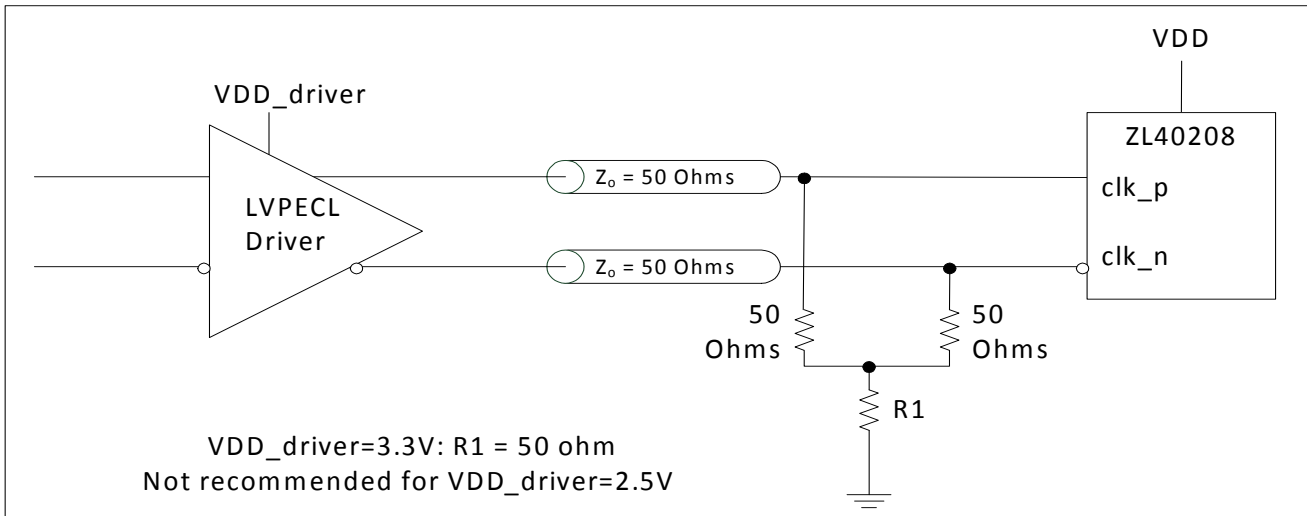

Figure 4 - LVPECL Input DC Coupled Thevenin Equivalent

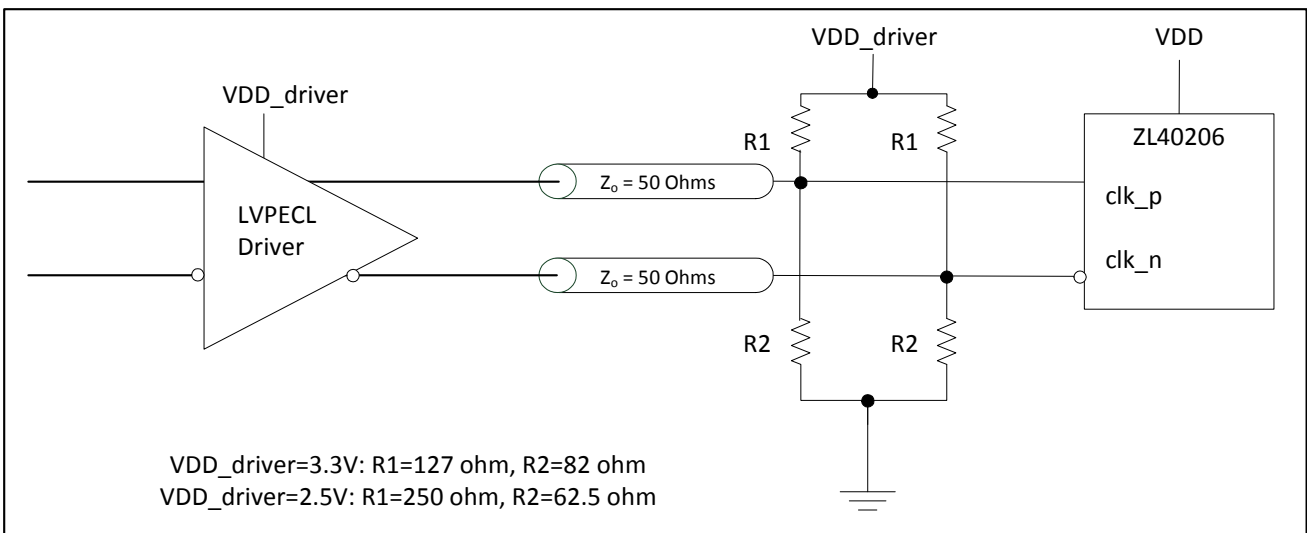

Figure 5 - LVPECL Input DC Coupled Parallel Termination

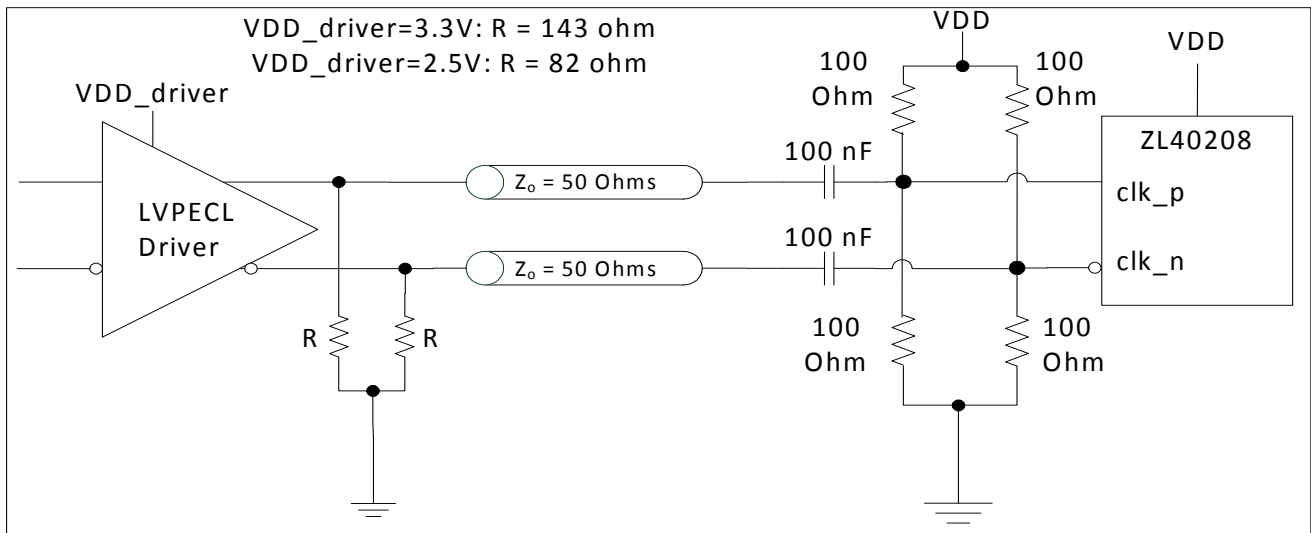

Figure 6 - LVPECL Input AC Coupled Termination

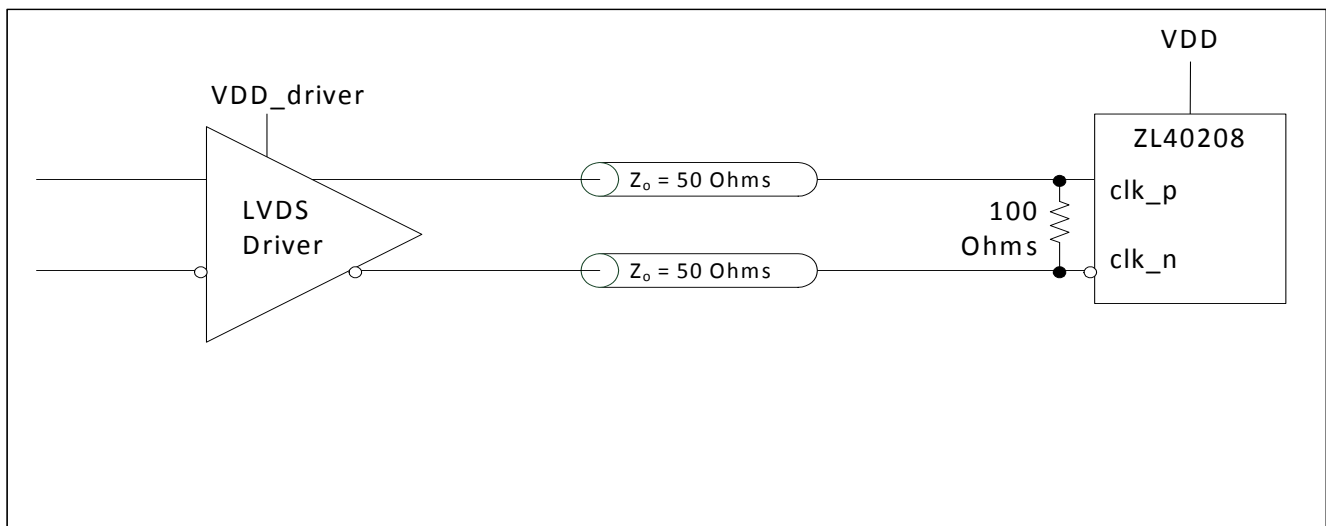

Figure 7 - LVDS Input DC Coupled

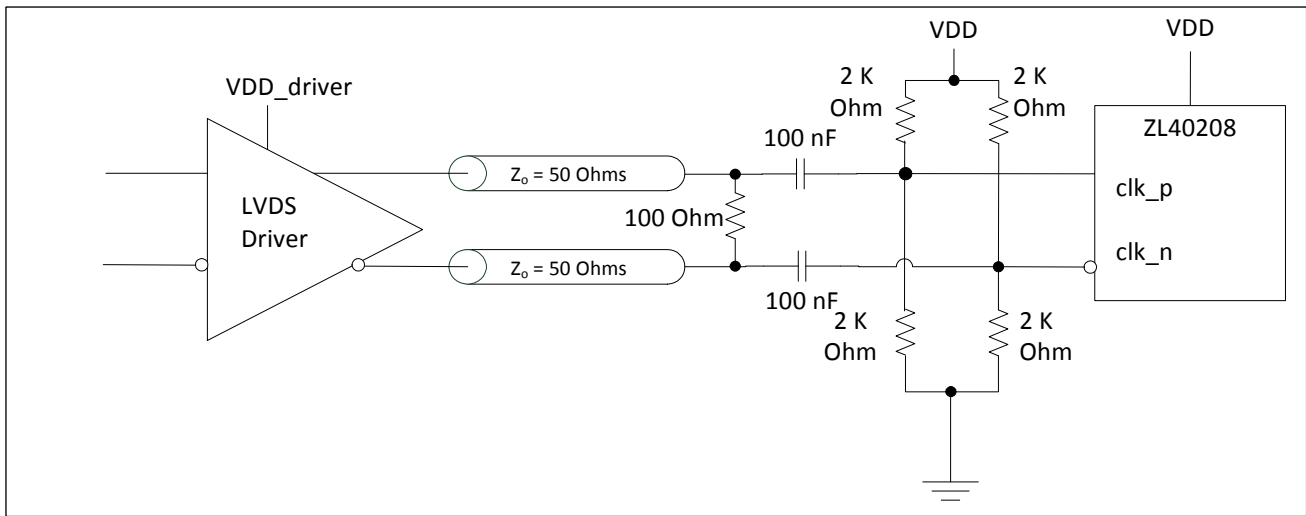

Figure 8 - LVDS Input AC Coupled

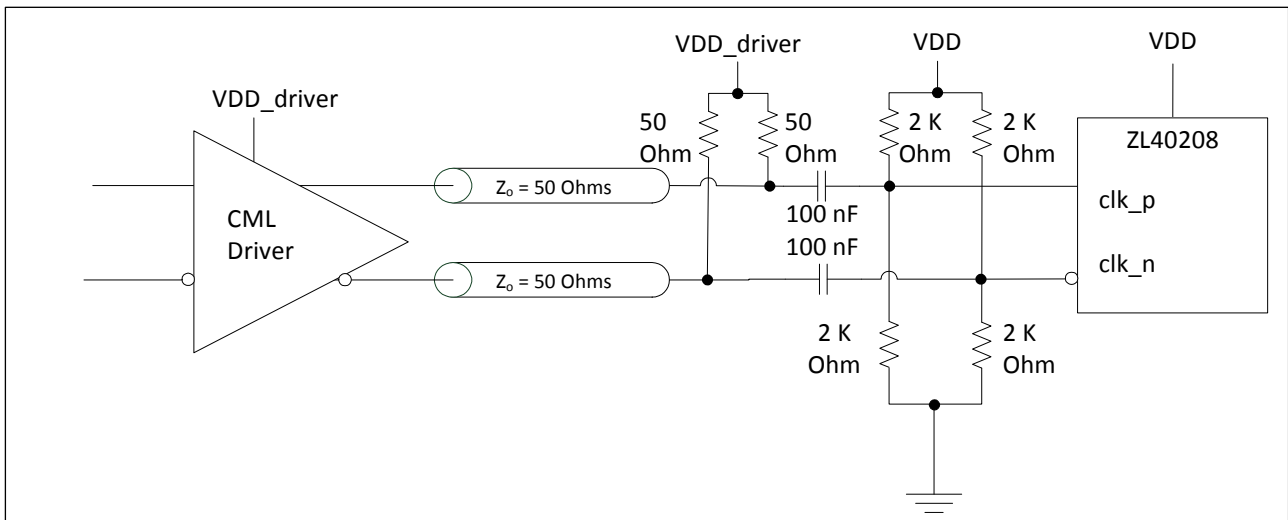

Figure 9 - CML Input AC Coupled

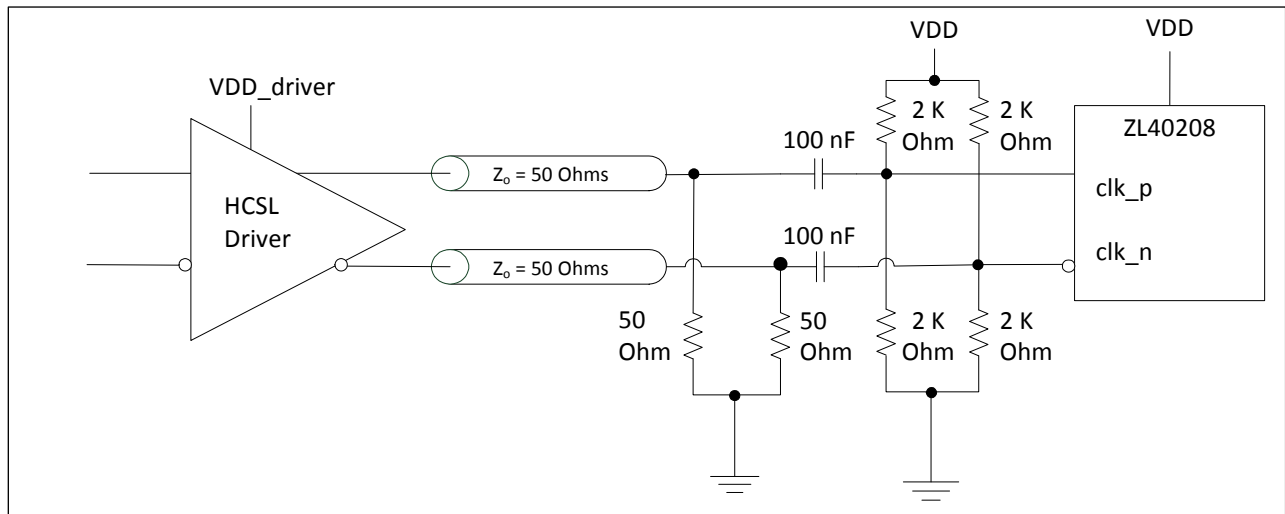

Figure 10 - HCSL Input AC Coupled

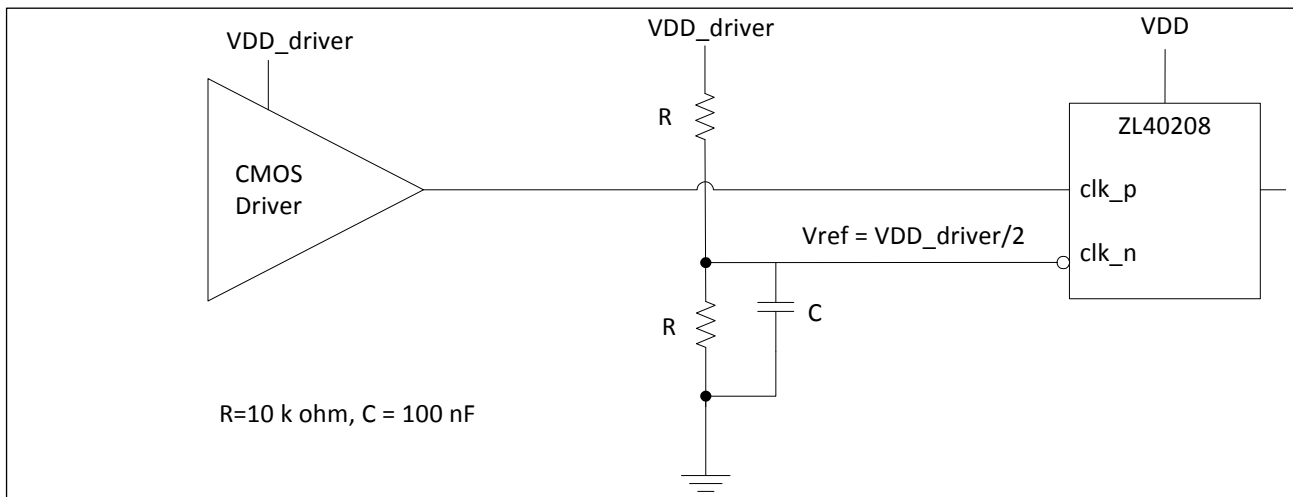

Figure 11 - CMOS Input DC Coupled Referenced to VDD/2

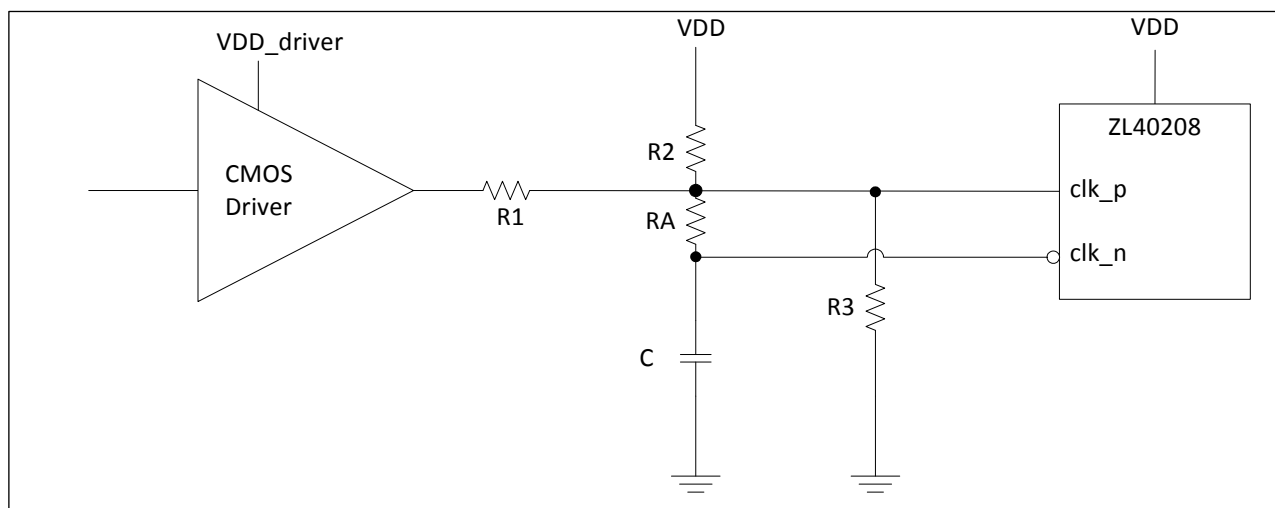

Figure 12 - CMOS Input DC Coupled Referenced to Ground

VDD_driver	R1 (kΩ)	R2 (kΩ)	R3 (kΩ)	RA (kΩ)	C (pF)
1.5	1.25	3.075	open	10	10
1.8	1	3.8	open	10	10
2.5	0.33	4.2	open	10	10
3.3	0.75	open	4.2	10	10

Table 2 - Component Values for Single Ended Input Reference to Ground

* For frequencies below 100 MHz, increase C to avoid signal integrity issues.

3.2 Clock Outputs

LVPECL has a very low output impedance and a differential signal swing between 1V and 1.6 V. A simplified diagram for the output stage is shown in Figure 13. The LVPECL to LVDS output termination is not shown since there is a separate device that has the same input and LVDS outputs.

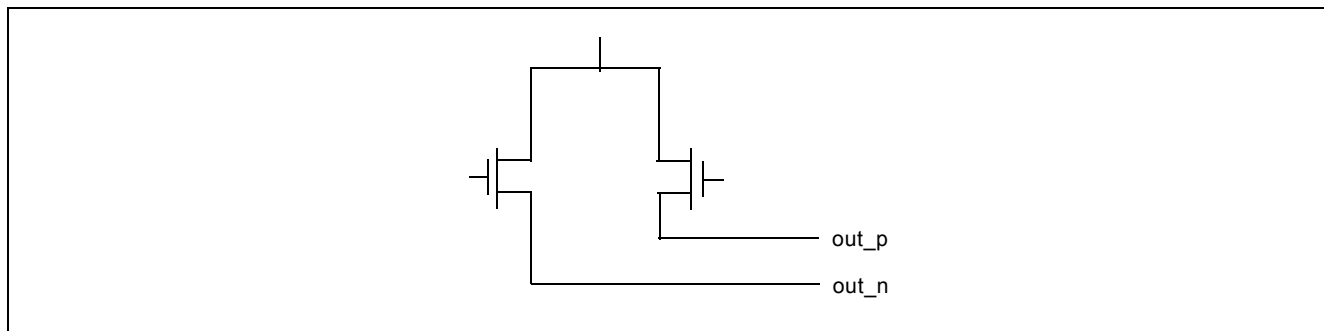

Figure 13 - Simplified Output Driver

The methods to terminate the ZL40208 LVPECL drivers are shown in the following figures.

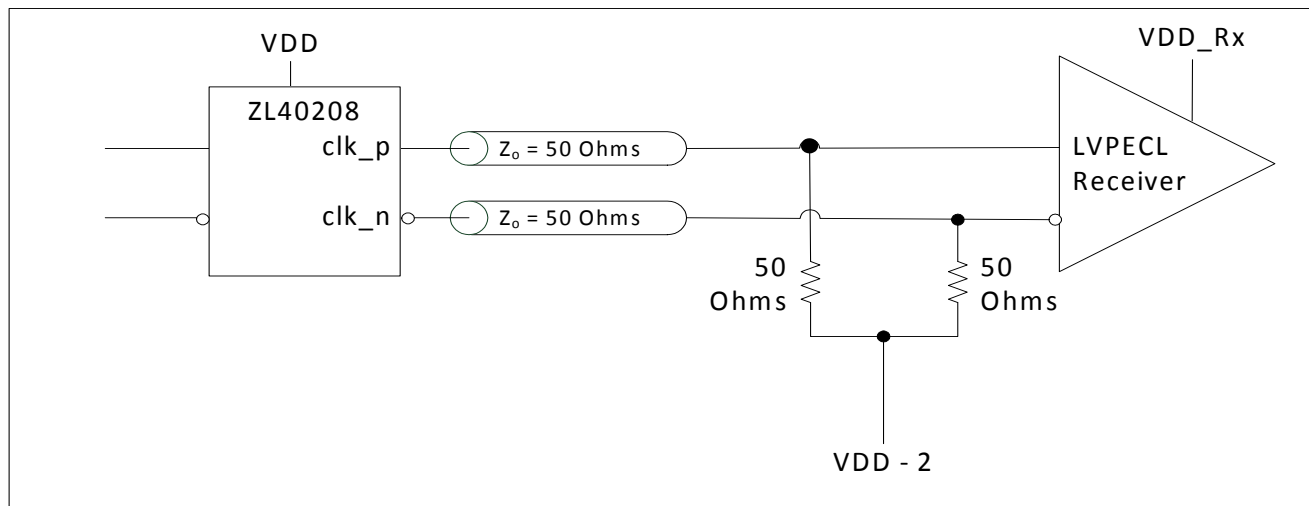

Figure 14 - LVPECL Basic Output Termination

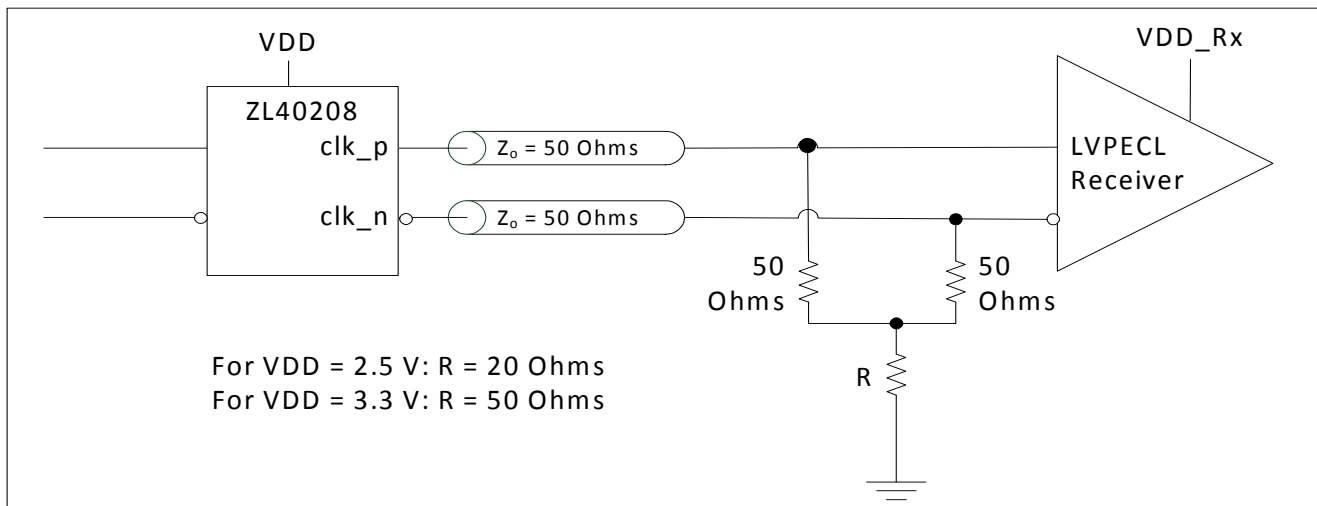

Figure 15 - LVPECL Parallel Output Termination

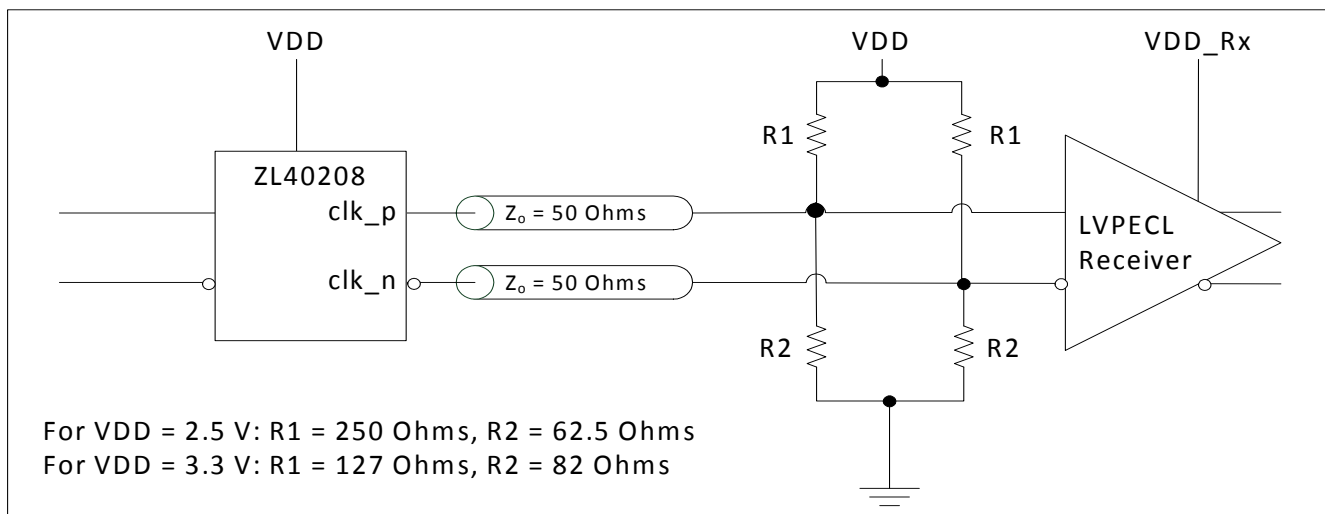

Figure 16 - LVPECL Parallel Thevenin-Equivalent Output Termination

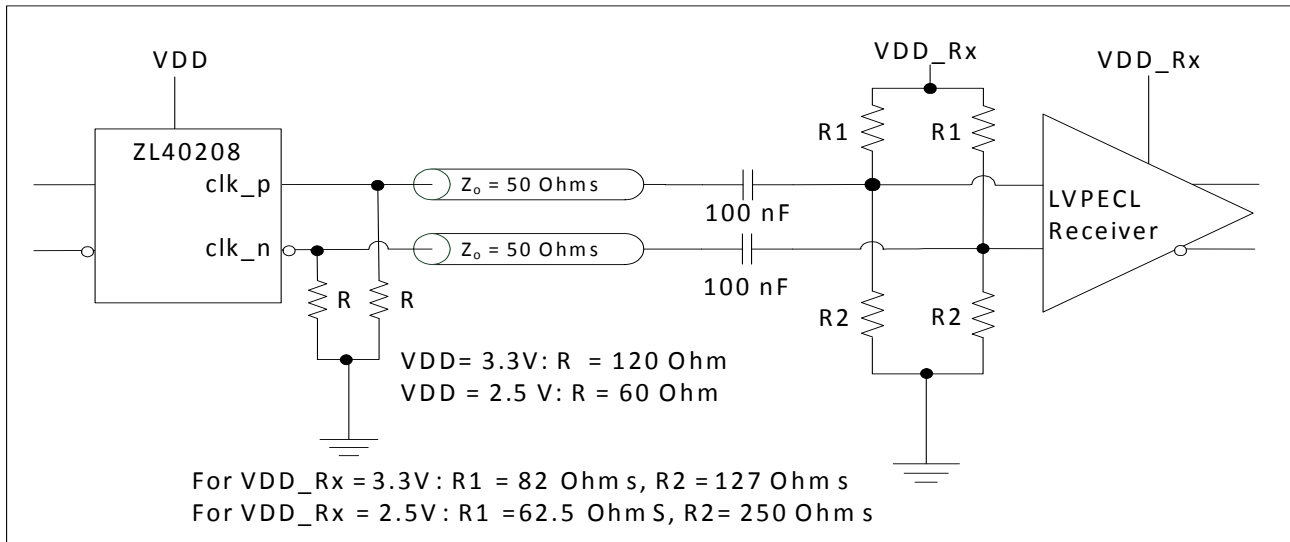

Figure 17 - LVPECL AC Output Termination for Externally Terminated LVPECL Inputs

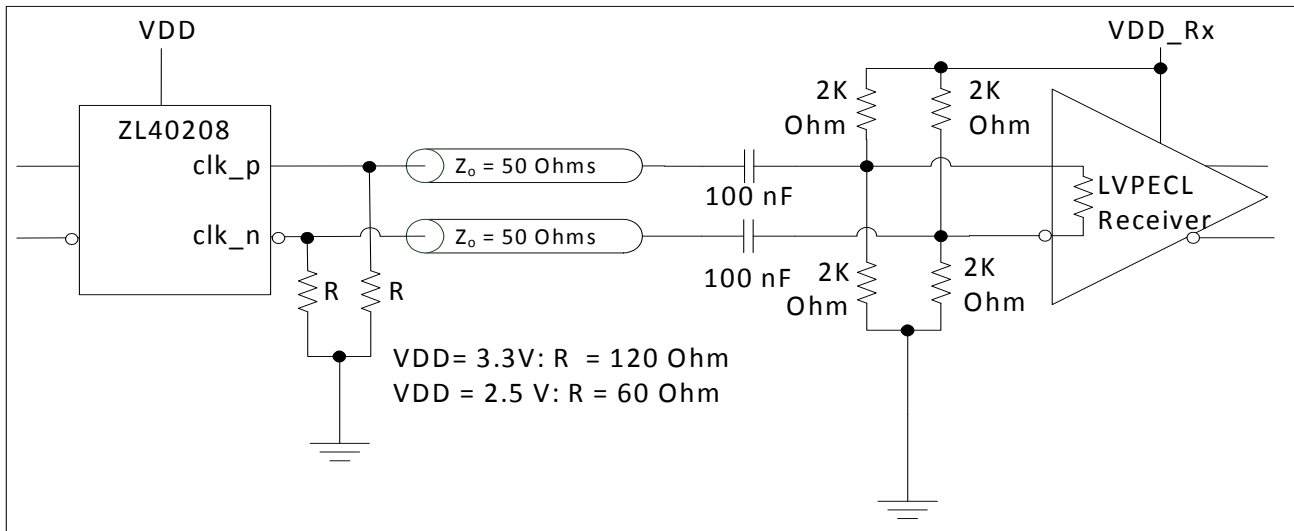

Figure 18 - LVPECL AC Output Termination for Internally Terminated LVPECL Inputs

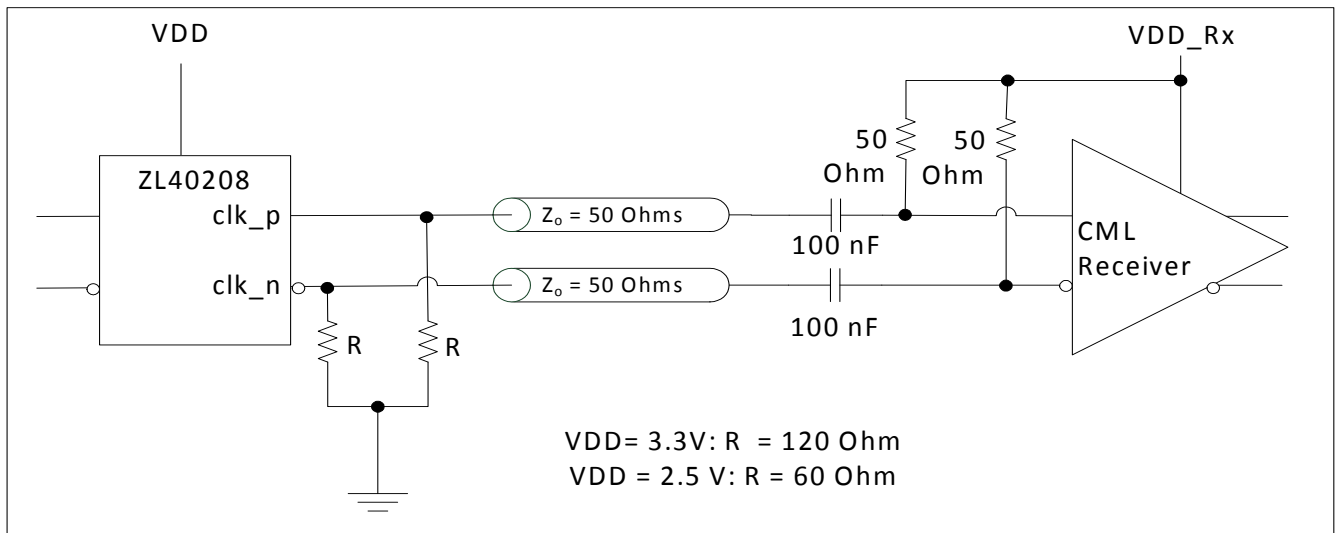

Figure 19 - LVPECL AC Output Termination for CML Inputs

3.3 Device Additive Jitter

The ZL40208 clock fan out buffer is not intended to filter clock jitter. The jitter performance of this type of device is characterized by its additive jitter. Additive jitter is the jitter the device would add to a hypothetical jitter-free clock as it passes through the device. The additive jitter of the ZL40208 is random and as such it is not correlated to the jitter of the input clock signal.

The square of the resultant random RMS jitter at the output of the ZL40208 is equal to the sum of the squares of the various random RMS jitter sources including: input clock jitter; additive jitter of the buffer; and additive jitter due to power supply noise. There may be additional deterministic jitter sources that are not shown in Figure 20.

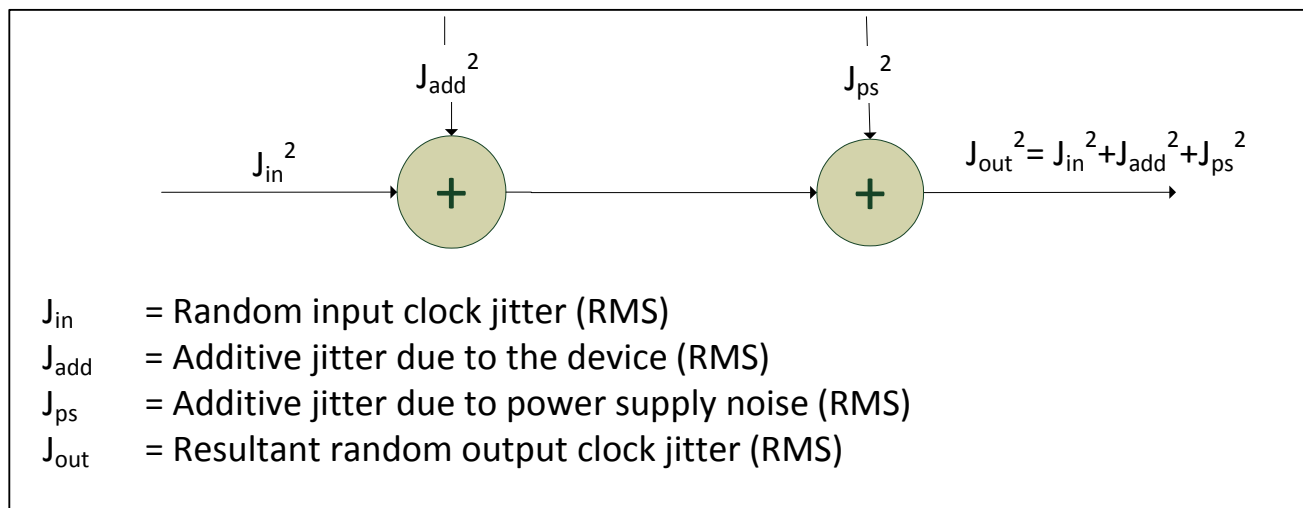

Figure 20 - Additive Jitter

3.4 Power Supply

This device operates with either a 2.5V supply or 3.3V supply.

3.4.1 Sensitivity to power supply noise

Power supply noise from sources such as switching power supplies and high-power digital components such as FPGAs can induce additive jitter on clock buffer outputs. The ZL40208 is equipped with an on-chip linear power regulator and on-chip bulk capacitors to minimize additive jitter due to power supply noise. The on-chip regulation, recommended power supply filtering, and good PCB layout all work together to minimize the additive jitter from power supply noise.

3.4.2 Power supply filtering

For optimal jitter performance, the ZL40208 should be isolated from the power planes connected to its power supply pins as shown in Figure 21.

- 10 μF capacitors should be size 0603 or size 0805 X5R or X7R ceramic, 6.3 V minimum rating
- 0.1 μF capacitors should be size 0402 X5R ceramic, 6.3 V minimum rating
- Capacitors should be placed next to the connected device power pins

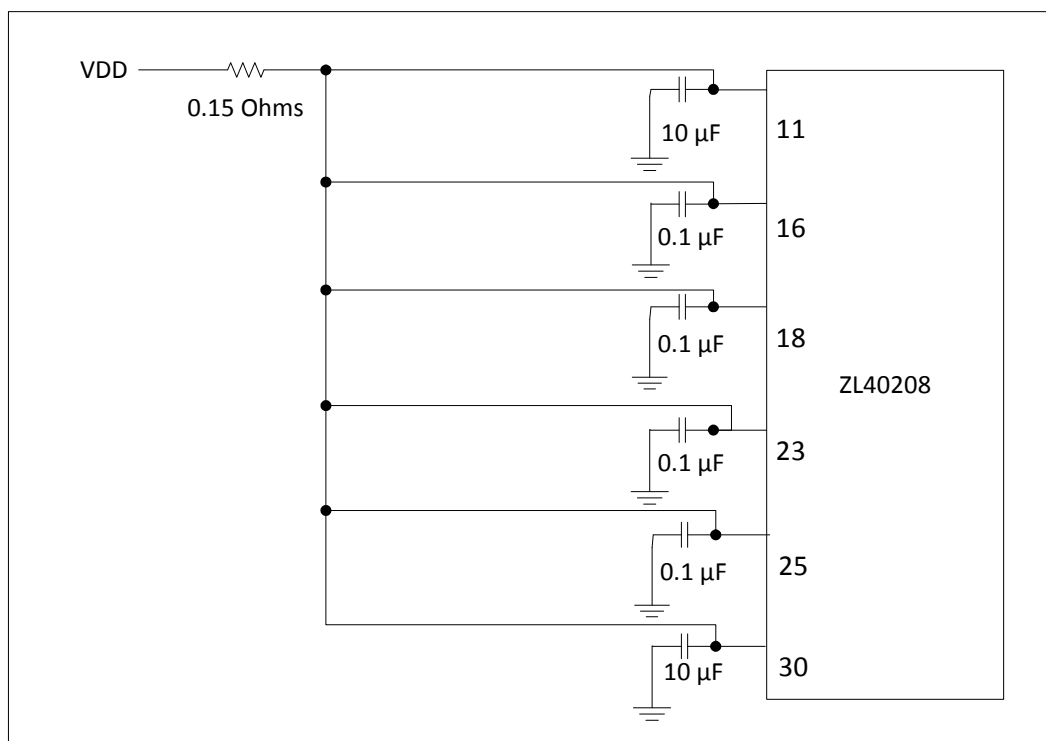

Figure 21 - Decoupling Connections for Power Pins

3.4.3 PCB layout considerations

The power supply filtering shown in Figure 21 can be implemented either as a plane island, or as a routed power topology with equal results.

4.0 AC and DC Electrical Characteristics

Absolute Maximum Ratings*

	Parameter	Sym.	Min.	Max.	Units
1	Supply voltage	V_{DD_R}	-0.5	4.6	V
2	Voltage on any digital pin	V_{PIN}	-0.5	V_{DD}	V
3	LVPECL output current	I_{out}		30	mA
4	Soldering temperature	T		260	°C
5	Storage temperature	T_{ST}	-55	125	°C
6	Junction temperature	T_j		125	°C
7	Voltage on input pin	V_{input}		V_{DD}	V
8	Input capacitance each pin	C_p		500	fF

* Exceeding these values may cause permanent damage. Functional operation under these conditions is not implied.

* Voltages are with respect to ground (GND) unless otherwise stated

Recommended Operating Conditions*

	Characteristics	Sym.	Min.	Typ.	Max.	Units
1	Supply voltage 2.5 V mode	V_{DD25}	2.375	2.5	2.625	V
2	Supply voltage 3.3 V mode	V_{DD33}	3.135	3.3	3.465	V
3	Operating temperature	T_A	-40	25	85	°C

* Voltages are with respect to ground (GND) unless otherwise stated

DC Electrical Characteristics - Current Consumption

	Characteristics	Sym.	Min.	Typ.	Max.	Units	Notes
1	Supply current LVPECL drivers - unloaded	I_{dd_unload}		110		mA	Unloaded
2	Supply current LVPECL drivers - loaded (all outputs are active)	I_{dd_load}		214		mA	Including power to $R_L = 50\Omega$

DC Electrical Characteristics - Inputs and Outputs - for 3.3 V Supply

	Characteristics	Sym.	Min.	Typ.	Max.	Units	Notes
1	Differential input common mode voltage	V_{CM}	1.1		2.0	V	
1	CMOS control logic high-level input voltage	V_{CIH}	$0.7 \cdot V_{DD}$			V	
2	CMOS control logic low-level input voltage	V_{CIL}			$0.3 \cdot V_{DD}$	V	
3	CMOS control logic Input leakage current	I_{IL}		1		μA	$V_I = V_{DD}$ or 0 V
4	Differential input voltage difference	V_{ID}	0.25		1	V	

DC Electrical Characteristics - Inputs and Outputs - for 3.3 V Supply

	Characteristics	Sym.	Min.	Typ.	Max.	Units	Notes
5	LVPECL output high voltage	V_{OH}	$V_{DD}-1.4$			V	
6	LVPECL output low voltage	V_{OL}			$V_{DD}-1.62$	V	
7	LVPECL output differential voltage*	V_{OD}	0.5		0.9	V	

* This parameter measured from 125 MHz to 750 MHz

DC Electrical Characteristics - Inputs and Outputs - for 2.5 V Supply

	Characteristics	Sym.	Min.	Typ.	Max.	Units	Notes
1	Differential input common mode voltage	V_{CM}	1.1		1.6	V	
1	CMOS control logic high-level input voltage	V_{CIH}	$0.7 \cdot V_{DD}$			V	
2	CMOS control logic low-level input voltage	V_{CIL}			$0.3 \cdot V_{DD}$	V	
3	CMOS control logic Input leakage current	I_{IL}		1		μA	$V_I = V_{DD}$ or 0 V
4	Differential input voltage difference	V_{ID}	0.25		1	V	
5	LVPECL output high voltage	V_{OH}	$V_{DD}-1.4$			V	
6	LVPECL output low voltage	V_{OL}			$V_{DD}-1.62$	V	
7	LVPECL output differential voltage*	V_{OD}	0.4		0.9	V	

* This parameter measured from 125 MHz to 750 MHz

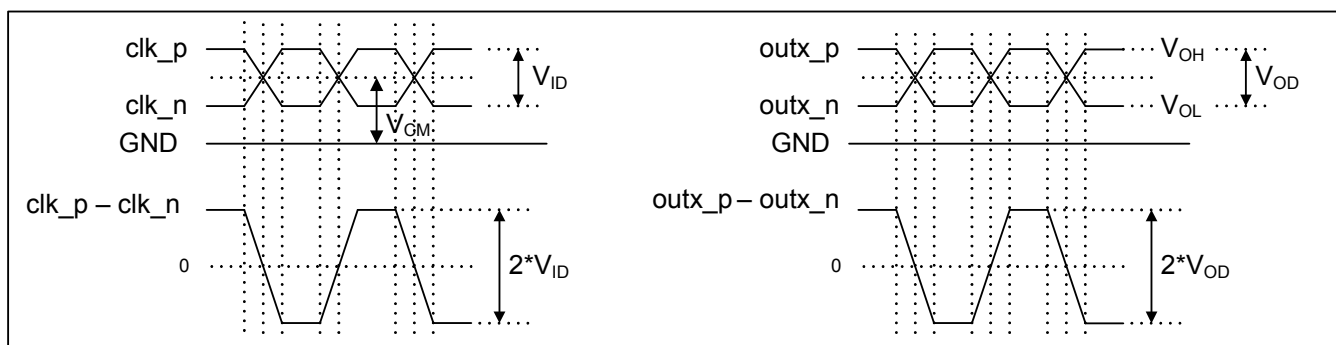

Figure 22 - Differential Voltages Parameter

AC Electrical Characteristics* - Inputs and Outputs (see Figure 23) - for 2.5/3.3 V supply.

	Characteristics	Sym.	Min.	Typ.	Max.	Units	Notes
1	Maximum Operating Frequency	$1/t_p$			750	MHz	
2	Input to output clock propagation delay	t_{pd}	0	1	2	ns	
3	Output to output skew	$t_{out2out}$		50	100	ps	
4	Part to part output skew	$t_{part2part}$		80	300	ps	
5	Output clock Duty Cycle degradation	t_{PWH}/t_{PWL}	-2	0	2	Percent	
6	LVPECL Output slew rate	r_{sl}	0.75	1.2		V/ns	
7	Reference transition time	t_{switch}		2	3	us	

* Supply voltage and operating temperature are as per Recommended Operating Conditions

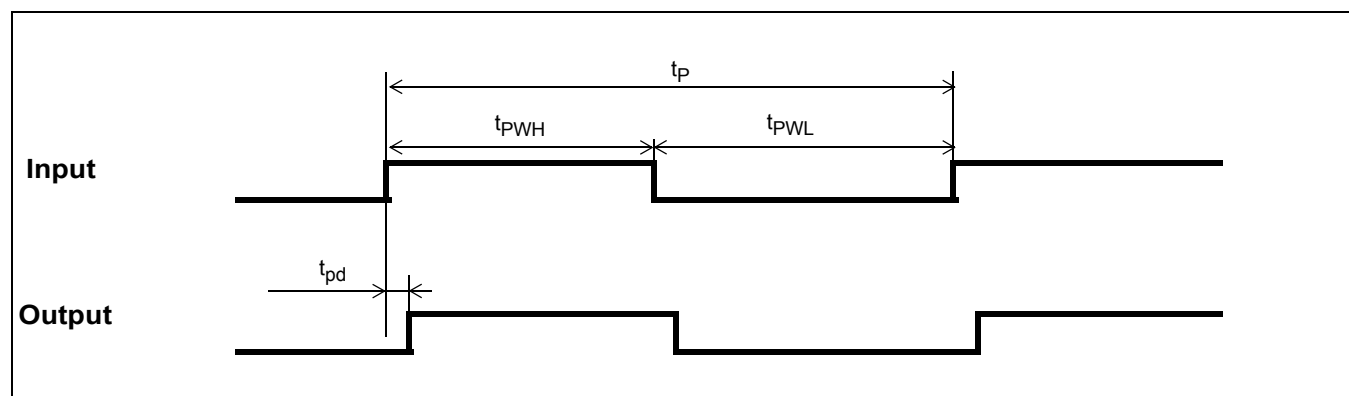

Figure 23 - Input To Output Timing

5.0 Performance Characterization

Additive Jitter at 2.5 V*

	Output Frequency (MHz)	Jitter Measurement Filter	Typical RMS (fs)	Notes
1	125	12 kHz - 20 MHz	214	
2	212.5	12 kHz - 20 MHz	188	
3	311.04	12 kHz - 20 MHz	168	
4	425	12 kHz - 20 MHz	151	
5	500	12 kHz - 20 MHz	144	
6	622.08	12 kHz - 20 MHz	135	
7	750	12 kHz - 20 MHz	121	

*The values in this table were taken with an approximate slew rate of 0.8 V/ns.

Additive Jitter at 3.3 V*

	Output Frequency (MHz)	Jitter Measurement Filter	Typical RMS (fs)	Notes
1	125	12 kHz - 20 MHz	209	
2	212.5	12 kHz - 20 MHz	184	
3	311.04	12 kHz - 20 MHz	176	
4	425	12 kHz - 20 MHz	163	
5	500	12 kHz - 20 MHz	157	
6	622.08	12 kHz - 20 MHz	146	
7	750	12 kHz - 20 MHz	131	

*The values in this table were taken with an approximate slew rate of 0.8 V/ns.

Additive Jitter from a Power Supply Tone*

Carrier frequency	Parameter	Typical	Units	Notes
125MHz	25 mV at 100 kHz	114	fs RMS	
750MHz	25 mV at 100 kHz	52	fs RMS	

* The values in this table are the additive periodic jitter caused by an interfering tone typically caused by a switching power supply. For this test, measurements were taken over the full temperature and voltage range for $V_{DD} = 2.5$ V. The magnitude of the interfering tone is measured at the DUT.

6.0 Typical Behavior

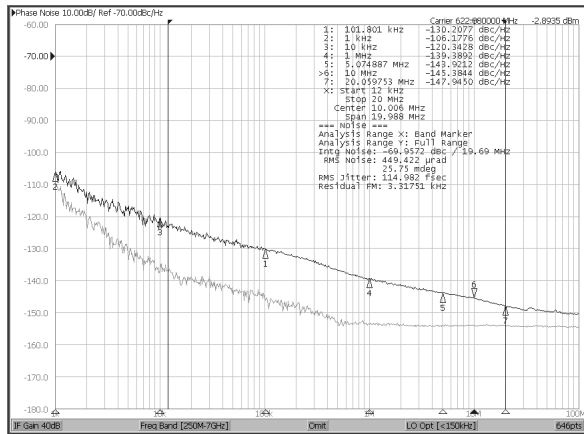

Typical Phase Noise at 622.08 MHz

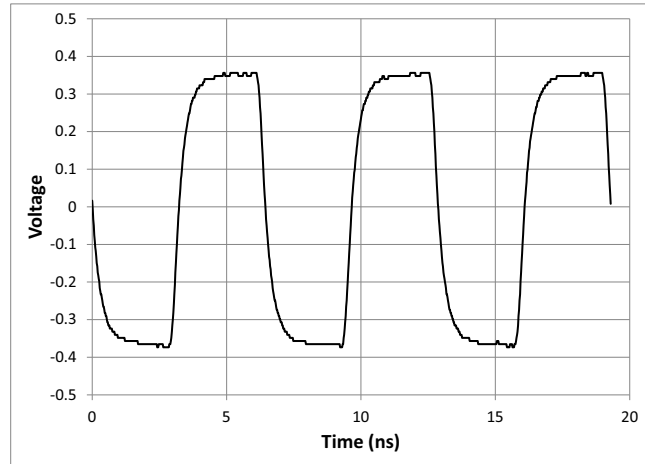

Typical Waveform at 155.52 MHz

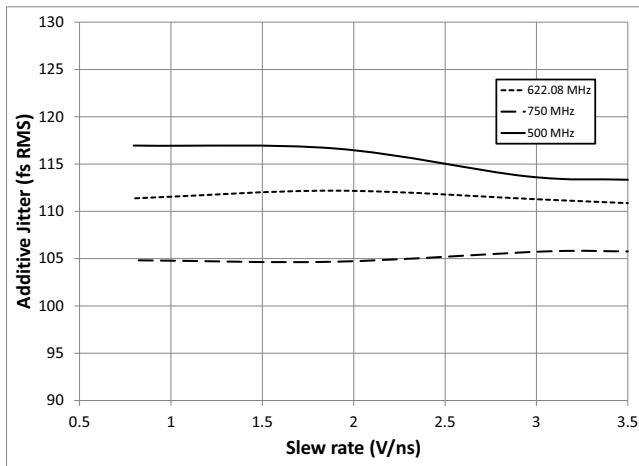

Input Slew Rate versus Additive Jitter

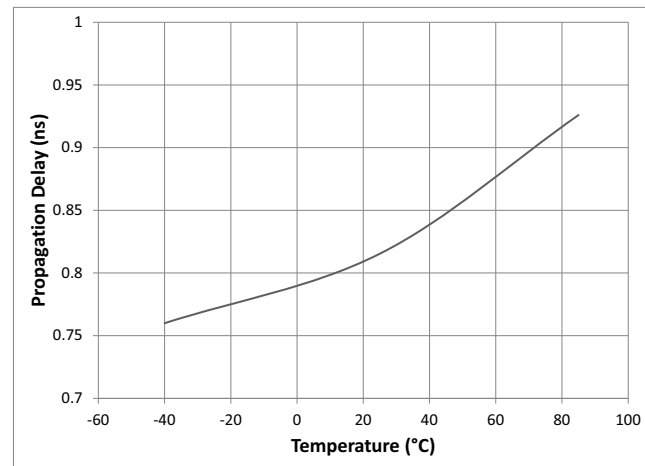

Propagation Delay versus Temperature

Note: This is for a single device. For more details see the

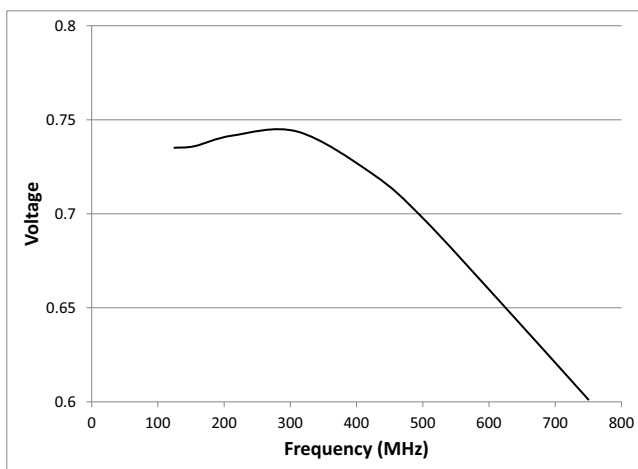

V_{OD} versus Frequency

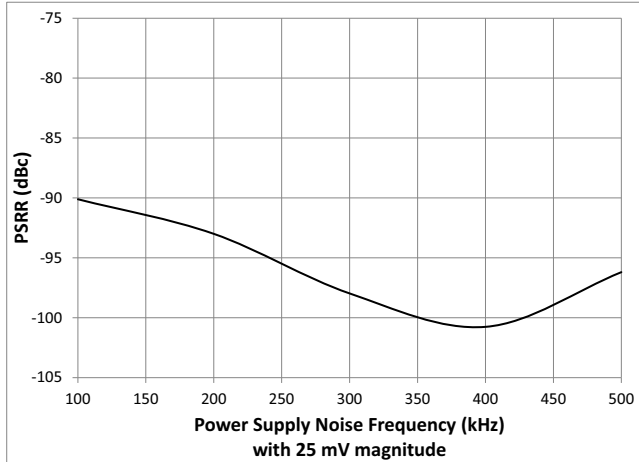

Power Supply Tone Frequency (at 25 mV) versus PSRR at 125 MHz

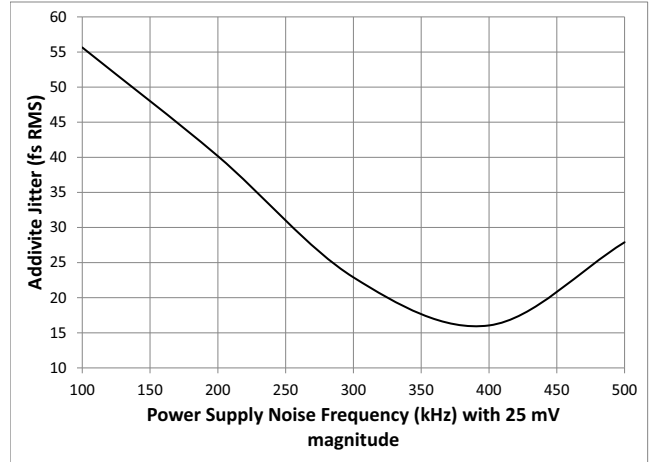

Power Supply Tone Frequency (at 25 mV) versus Additive Jitter at 125 MHz

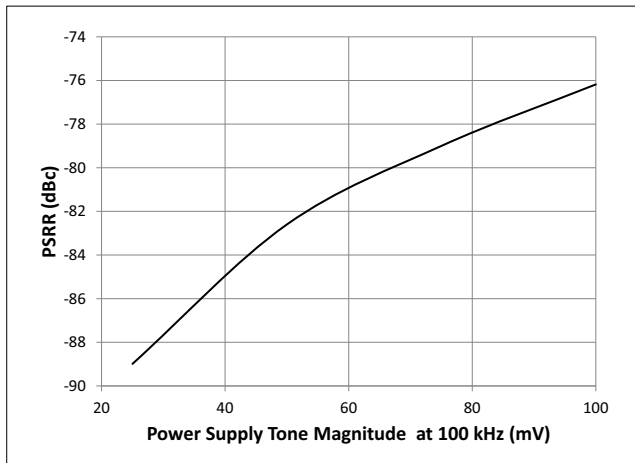

Power Supply Tone Magnitude (at 100 kHz) versus PSRR at 125 MHz

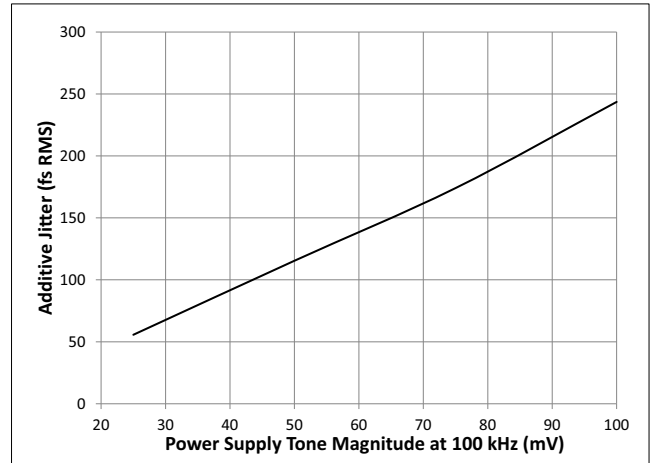

Power Supply Tone Magnitude (at 100 kHz) versus Additive Jitter at 125 MHz

7.0 Package Characteristics

Thermal Data

Parameter	Symbol	Test Condition	Value	Unit
Junction to Ambient Thermal Resistance	Θ_{JA}	Still Air	37.4	$^{\circ}\text{C}/\text{W}$
		1 m/s	33.1	
		2 m/s	31.5	
Junction to Case Thermal Resistance	Θ_{JC}		24.4	$^{\circ}\text{C}/\text{W}$
Junction to Board Thermal Resistance	Θ_{JB}		19.5	$^{\circ}\text{C}/\text{W}$
Maximum Junction Temperature*	T_{jmax}		125	$^{\circ}\text{C}$
Maximum Ambient Temperature	T_A		85	$^{\circ}\text{C}$

8.0 Mechanical Drawing

