

Features

Inputs/Outputs

- Accepts differential or single-ended input
 - LVPECL, LVDS, CML, HCSL, LVCMOS
- Four precision LVDS outputs
- Operating frequency up to 750 MHz

Power

- Options for 2.5 V or 3.3 V power supply
- On-chip Low Drop Out (LDO) Regulator for superior power supply noise rejection
- Current consumption of 61 mA

Performance

- Ultra low additive jitter of 92 fs RMS

Ordering Information

ZL40214LDG1	16 Pin QFN	Trays
ZL40214LDF1	16 Pin QFN	Tape and Reel
Matte Tin		
Package size: 3 x 3 mm		
-40°C to +85°C		

Applications

- General purpose clock distribution
- Low jitter clock trees
- Logic translation
- Clock and data signal restoration
- Wired communications: OTN, SONET/SDH, GE, 10 GE, FC and 10G FC
- Wireless communications
- High performance micro-processor clock distribution

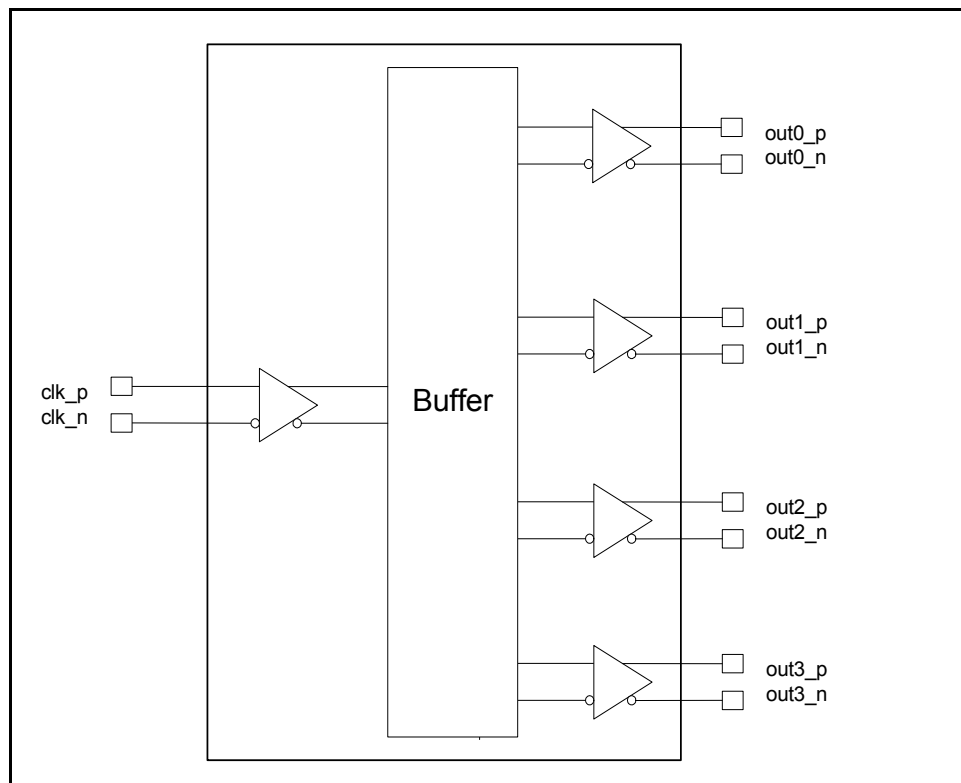

Figure 1 - Functional Block Diagram

Table of Contents

Features	1
Inputs/Outputs	1
Power	1
Performance	1
Applications	1
1.0 Package Description	4
2.0 Pin Description	4
3.0 Functional Description	5
3.1 Clock Inputs	5
3.2 Clock Outputs	10
3.3 Device Additive Jitter	13
3.4 Power Supply	14
3.4.1 Sensitivity to power supply noise	14
3.4.2 Power supply filtering	14
3.4.3 PCB layout considerations	14
4.0 AC and DC Electrical Characteristics	15
5.0 Performance Characterization	17
6.0 Typical Behavior	18
7.0 Package Thermal Characteristics	19
8.0 Mechanical Drawing	20

List of Figures

Figure 1 - Functional Block Diagram	1
Figure 2 - Pin Connections	4
Figure 3 - LVPECL Input DC Coupled Thevenin Equivalent	5
Figure 4 - LVPECL Input DC Coupled Parallel Termination	6
Figure 5 - LVPECL Input AC Coupled Termination	6
Figure 6 - LVDS Input DC Coupled	7
Figure 7 - LVDS Input AC Coupled	7
Figure 8 - CML Input AC Coupled	8
Figure 9 - HCSL Input AC Coupled	8
Figure 10 - CMOS Input DC Coupled Referenced to VDD/2	9
Figure 11 - CMOS Input DC Coupled Referenced to Ground	9
Figure 12 - Simplified LVDS Output Driver	10
Figure 13 - LVDS DC Coupled Termination (Internal Receiver Termination)	10
Figure 14 - LVDS DC Coupled Termination (External Receiver Termination)	11
Figure 15 - LVDS AC Coupled Termination	11
Figure 16 - LVDS AC Output Termination for CML Inputs	12
Figure 17 - Additive Jitter	13
Figure 18 - Decoupling Connections for Power Pins	14
Figure 19 - Differential Voltage Parameter	16
Figure 20 - Input To Output Timing	16

1.0 Package Description

The device is packaged in a 16 pin QFN

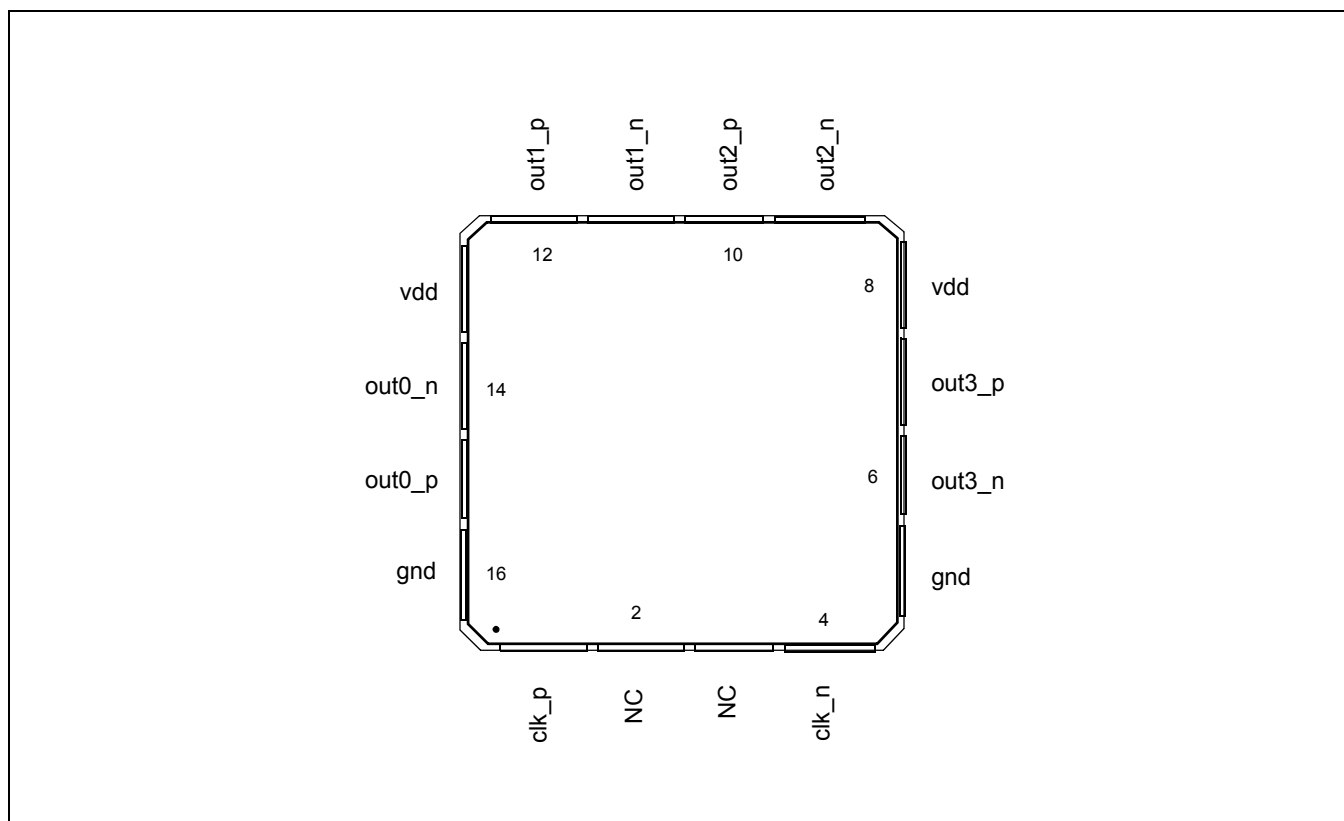

Figure 2 - Pin Connections

2.0 Pin Description

Pin #	Name	Description
1, 4	clk_p, clk_n,	Differential Input (Analog Input). Differential (or singled ended) input signals. For all input signal configuration see "Clock Inputs" on page 5
15,14, 12, 11, 10, 9, 7, 6	out0_p, out0_n out1_p, out1_n out2_p, out2_n out3_p, out3_n	Differential Output (Analog Output). Differential outputs.
8, 13	vdd	Positive Supply Voltage. 2.5 V _{DC} or 3.3 V _{DC} nominal.
5, 16	gnd	Ground. 0 V.
2, 3	NC	No Connection. Leave unconnected.

3.0 Functional Description

The ZL40214 is an LVDS clock fanout buffer with four identical output clock drivers capable of operating at frequencies up to 750MHz.

Inputs to the ZL40214 are externally terminated to allow use of precision termination components and to allow full flexibility of input termination. The ZL40214 can accept DC or AC coupled LVPECL, LVDS, CML or HCSL input signals; single ended input signals can also be accepted. A pin compatible device with internal termination is also available.

The ZL40214 is designed to fan out low-jitter reference clocks for wired or optical communications applications while adding minimal jitter to the clock signal. An internal linear power supply regulator and bulk capacitors minimize additive jitter due to power supply noise. The device operates from 2.5V \pm 5% or 3.3V \pm 5% supply. Its operation is guaranteed over the industrial temperature range -40°C to +85°C.

The device block diagram is shown in Figure 1; its operation is described in the following sections.

3.1 Clock Inputs

The ZL40214 is adaptable to support different types of differential and single-ended input signals depending on the passive components used in the input termination. The application diagrams in the following figures allow the ZL40214 to accept LVPECL, LVDS, CML, HCSL and single-ended inputs.

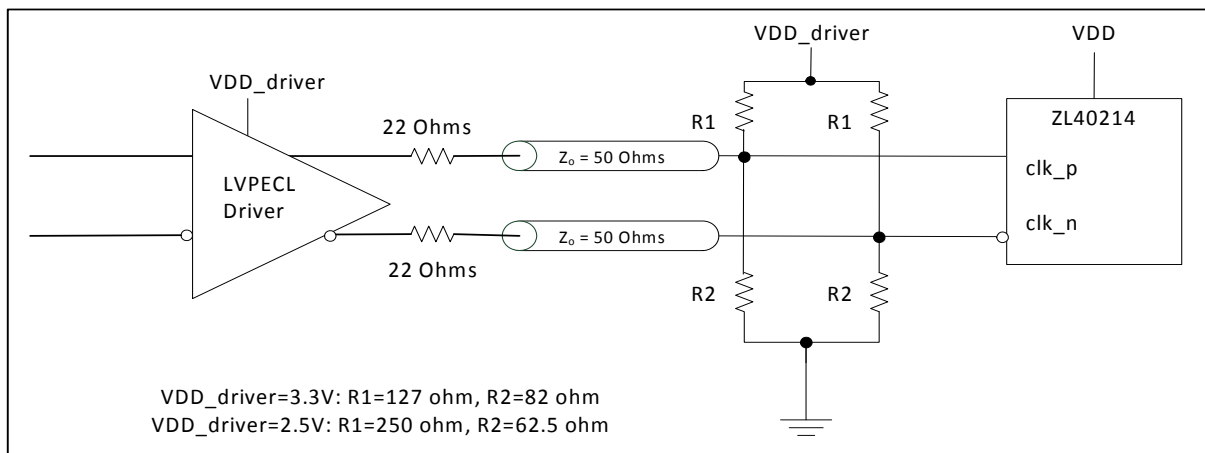

Figure 3 - LVPECL Input DC Coupled Thevenin Equivalent

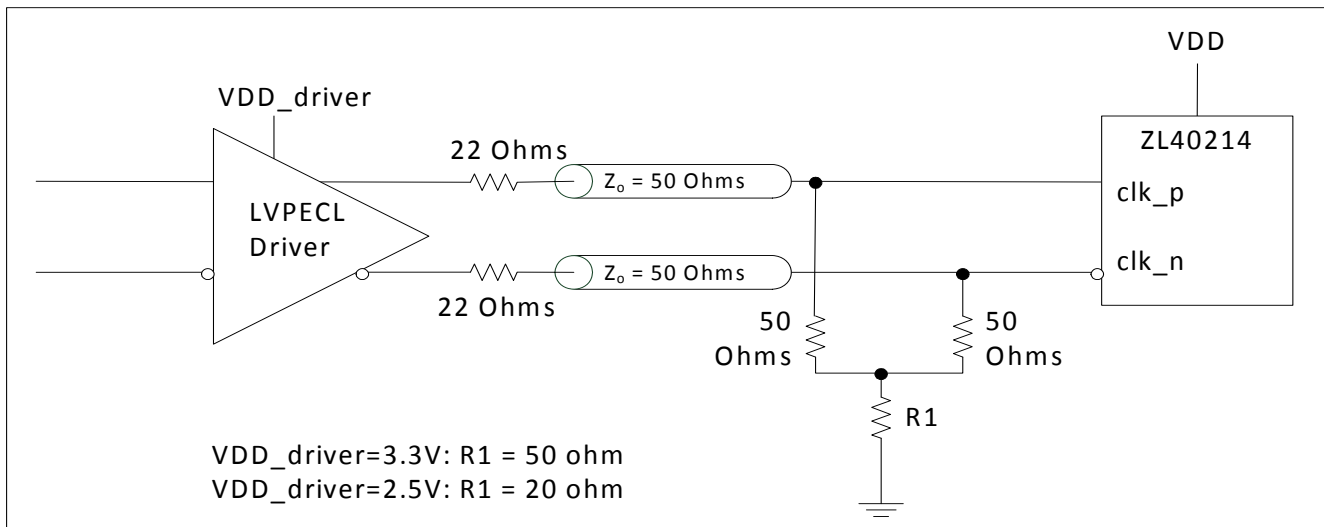

Figure 4 - LVPECL Input DC Coupled Parallel Termination

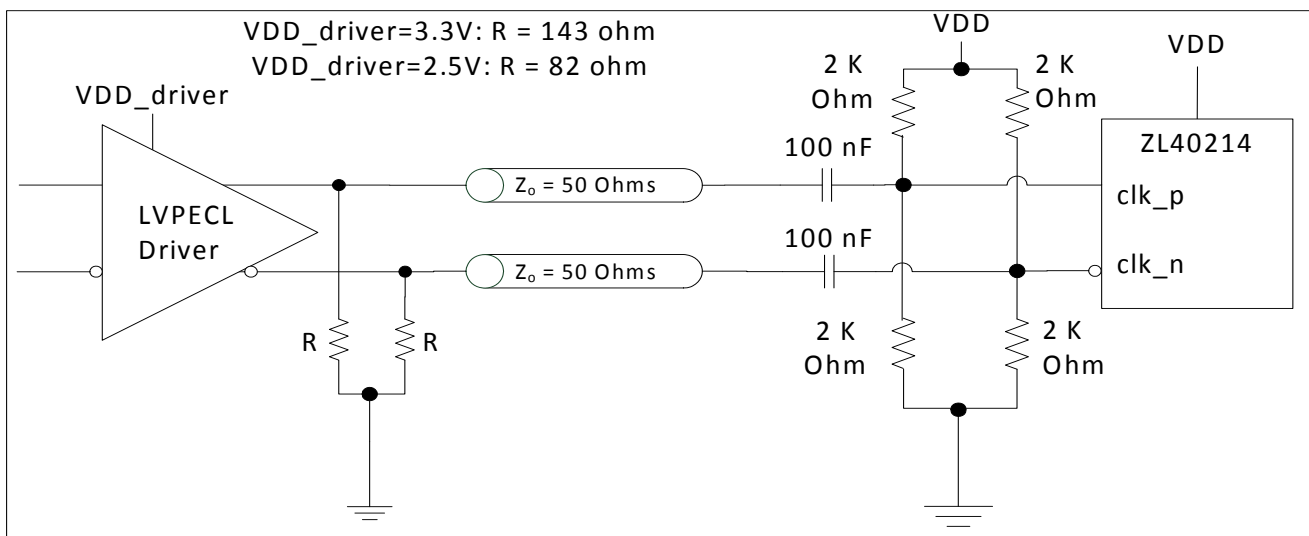

Figure 5 - LVPECL Input AC Coupled Termination

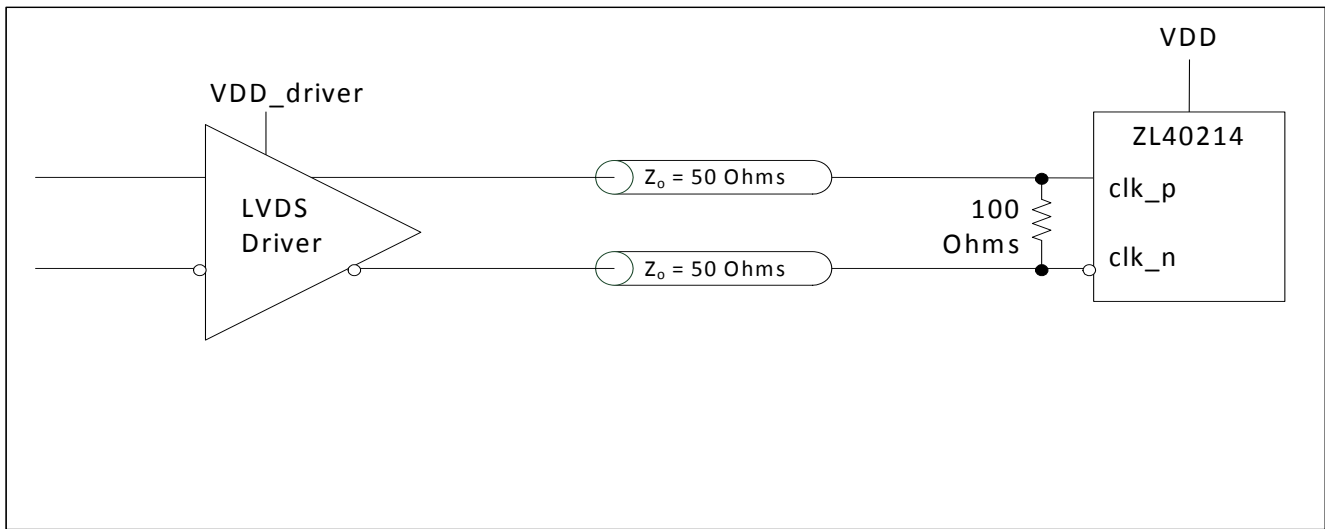

Figure 6 - LVDS Input DC Coupled

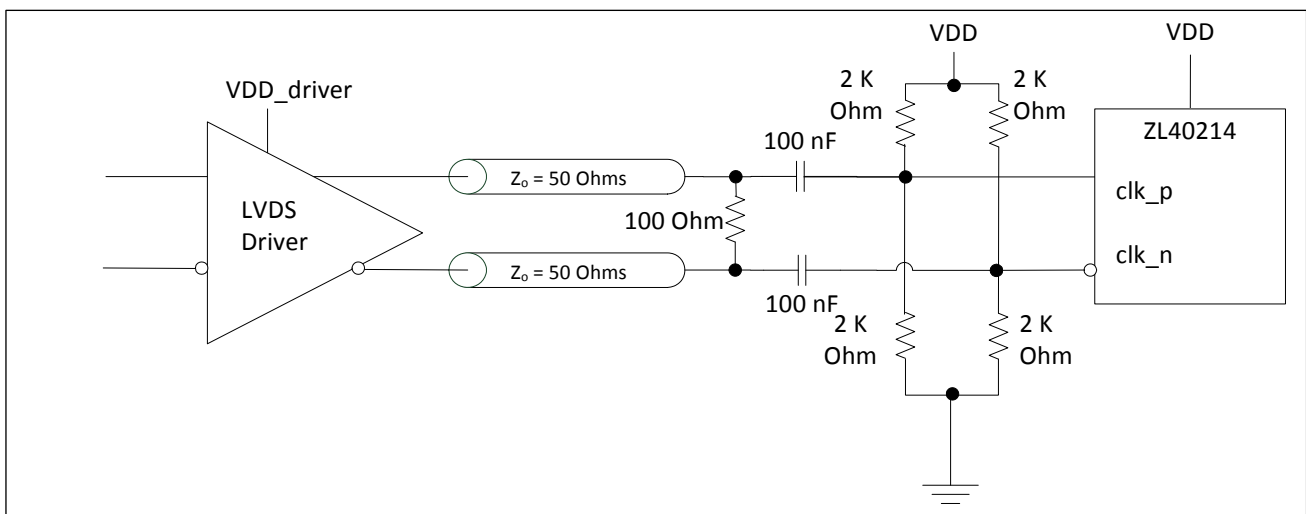

Figure 7 - LVDS Input AC Coupled

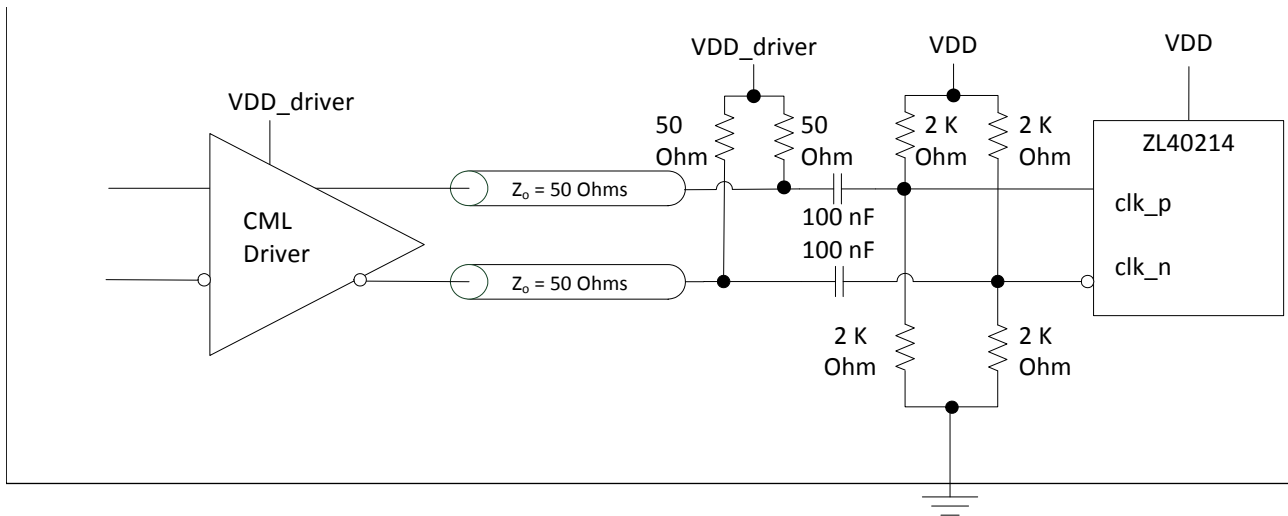

Figure 8 - CML Input AC Coupled

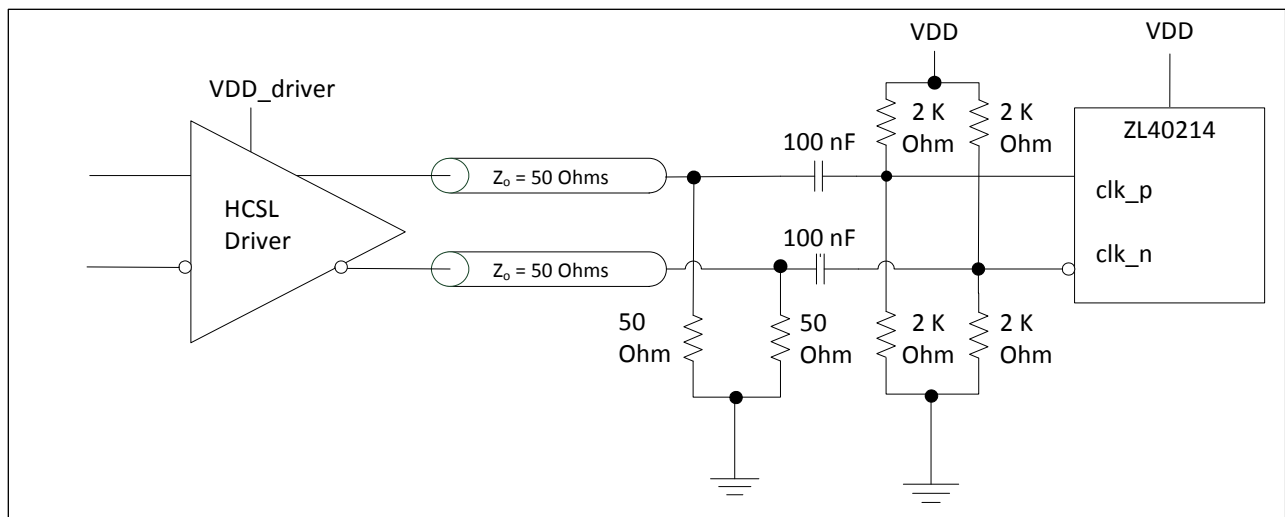

Figure 9 - HCSL Input AC Coupled

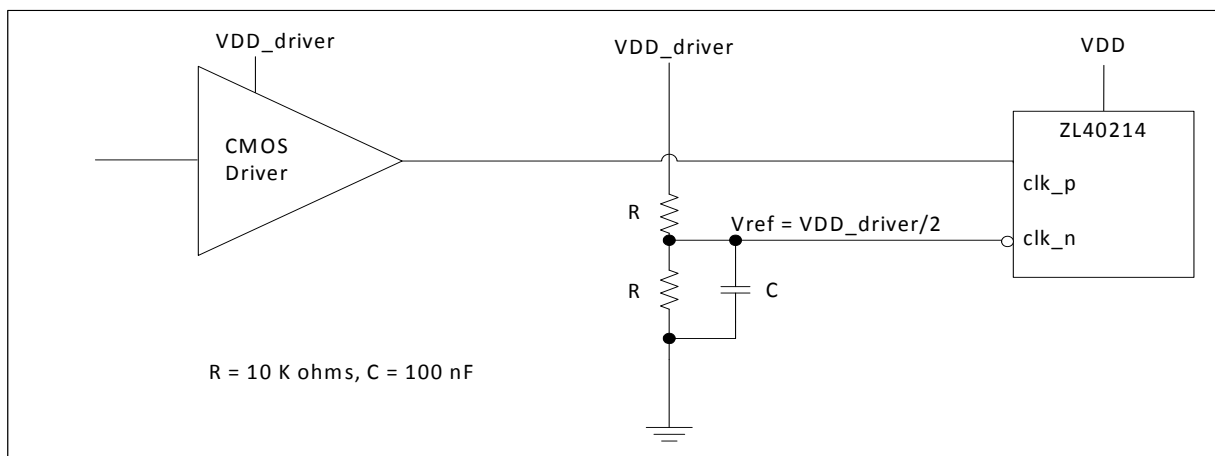

Figure 10 - CMOS Input DC Coupled Referenced to VDD/2

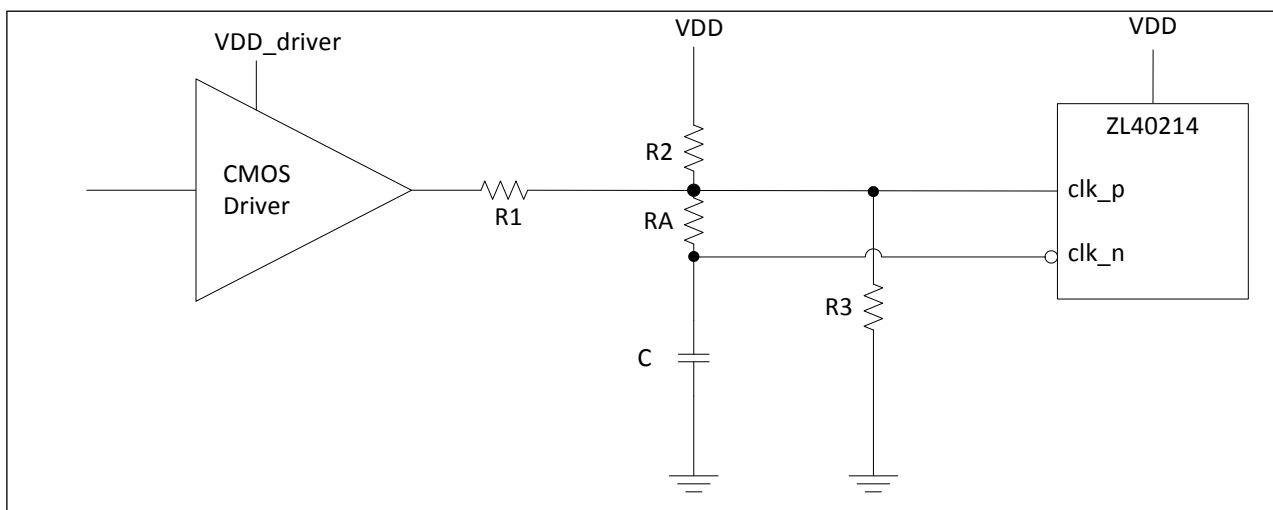

Figure 11 - CMOS Input DC Coupled Referenced to Ground

VDD_driver	R1 (kΩ)	R2 (kΩ)	R3 (kΩ)	RA (kΩ)	C (pF)
1.5	1.25	3.075	open	10	10
1.8	1	3.8	open	10	10
2.5	0.33	4.2	open	10	10
3.3	0.75	open	4.2	10	10

Table 1 - Component Values for Single Ended Input Reference to Ground

* For frequencies below 100 MHz, increase C to avoid signal integrity issues.

3.2 Clock Outputs

LVDS has lower signal swing than LVPECL which results in a low power consumption. A simplified diagram for the LVDS output stage is shown in Figure 12.

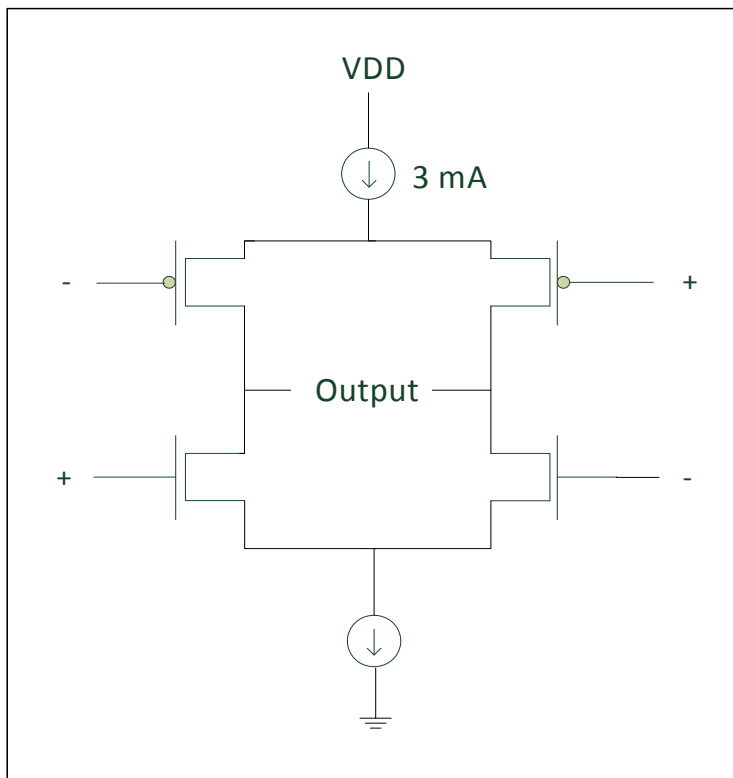

Figure 12 - Simplified LVDS Output Driver

The methods to terminate the ZL40214 drivers are shown in the following figures.

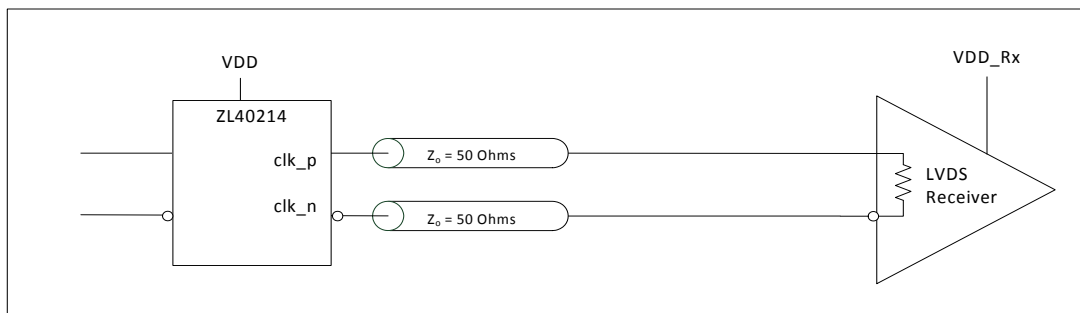

Figure 13 - LVDS DC Coupled Termination (Internal Receiver Termination)

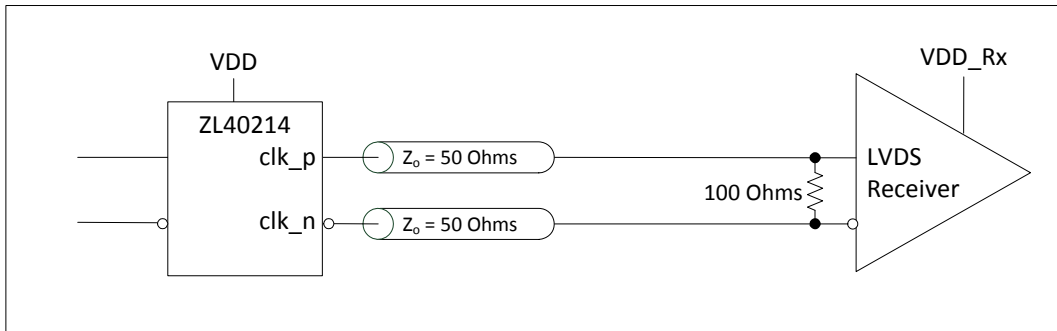

Figure 14 - LVDS DC Coupled Termination (External Receiver Termination)

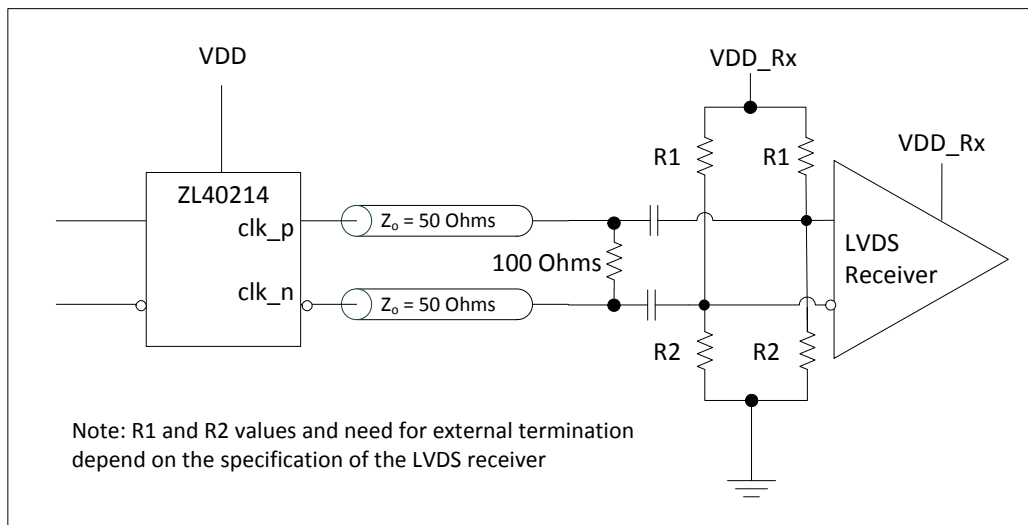

Figure 15 - LVDS AC Coupled Termination

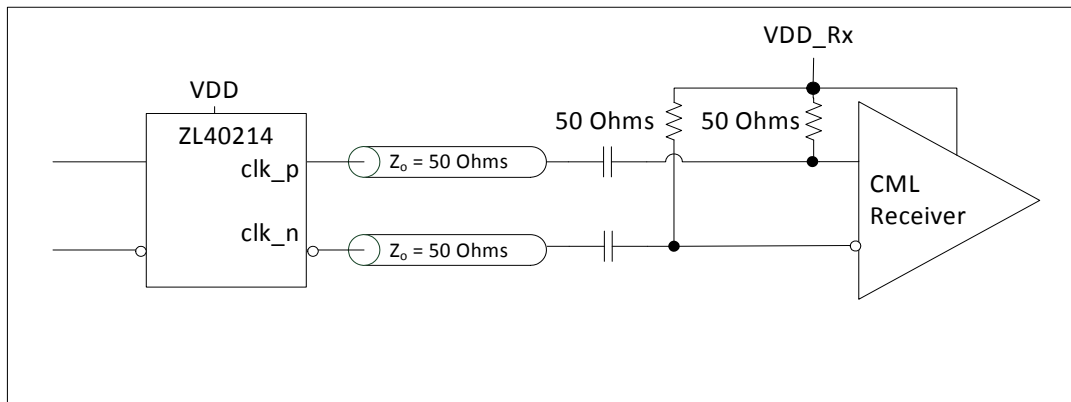

Figure 16 - LVDS AC Output Termination for CML Inputs

3.3 Device Additive Jitter

The ZL40214 clock fanout buffer is not intended to filter clock jitter. The jitter performance of this type of device is characterized by its additive jitter. Additive jitter is the jitter the device would add to a hypothetical jitter-free clock as it passes through the device. The additive jitter of the ZL40214 is random and as such it is not correlated to the jitter of the input clock signal.

The square of the resultant random RMS jitter at the output of the ZL40214 is equal to the sum of the squares of the various random RMS jitter sources including: input clock jitter; additive jitter of the buffer; and additive jitter due to power supply noise. There may be additional deterministic jitter sources, but they are not shown in Figure 17.

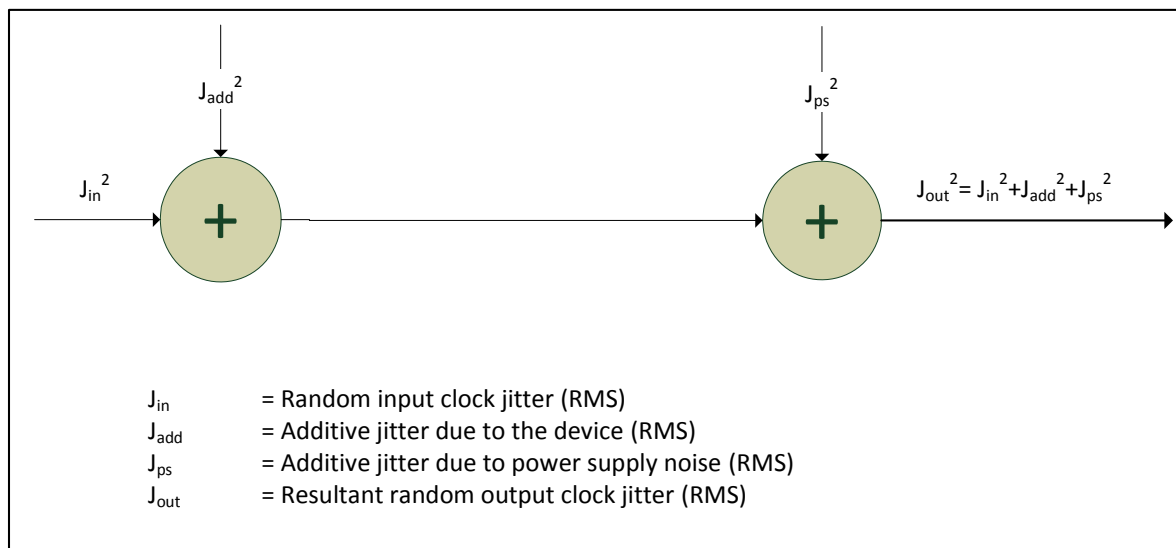

Figure 17 - Additive Jitter

3.4 Power Supply

This device operates with either a 2.5V supply or 3.3V supply.

3.4.1 Sensitivity to power supply noise

Power supply noise from sources such as switching power supplies and high-power digital components such as FPGAs can induce additive jitter on clock buffer outputs. The ZL40214 is equipped with a low drop out (LDO) power regulator and on-chip bulk capacitors to minimize additive jitter due to power supply noise. The LDO regulator on the ZL40214 allows this device to have superior performance even in the presence of external noise sources. The on-chip measures in combination with the simple recommended power supply filtering and PCB layout minimize the additive jitter from power supply noise.

The performance of these clock buffers in the presence of power supply noise is detailed in ZLAN-403, "Power Supply Rejection in Clock Buffers" which is available from Applications Engineering.

3.4.2 Power supply filtering

For optimal jitter performance, the device should be isolated from the power planes connected to its power supply pins as shown in Figure 18.

- 10 μF capacitors should be size 0603 or size 0805 X5R or X7R ceramic, 6.3 V minimum rating
- 0.1 μF capacitors should be size 0402 X5R ceramic, 6.3 V minimum rating
- Capacitors should be placed next to the connected device power pins
- a 0.3 ohm resistor is recommended for the filter shown in Figure 18

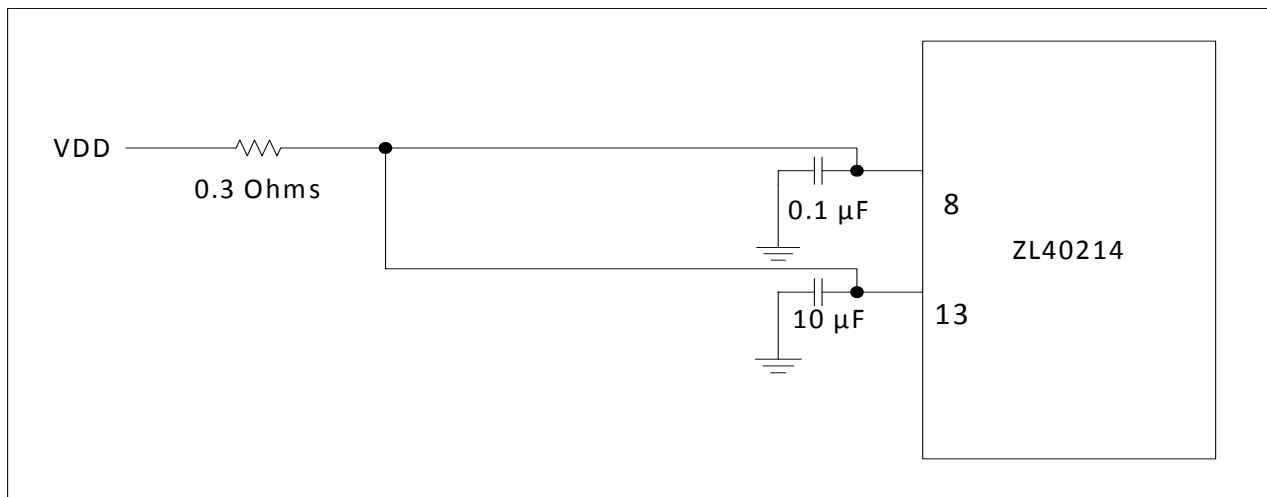

Figure 18 - Decoupling Connections for Power Pins

3.4.3 PCB layout considerations

The power nets in Figure 18 can be implemented either as a plane island or routed power topology without changing the overall jitter performance of the device.

4.0 AC and DC Electrical Characteristics

Absolute Maximum Ratings*

	Parameter	Sym.	Min.	Max.	Units
1	Supply voltage	V_{DD_R}	-0.5	4.6	V
2	Voltage on any digital pin	V_{PIN}	-0.5	V_{DD}	V
3	Soldering temperature	T		260	°C
4	Storage temperature	T_{ST}	-55	125	°C
5	Junction temperature	T_j		125	°C
6	Voltage on input pin	V_{input}		V_{DD}	V
7	Input capacitance each pin	C_p		500	fF

* Exceeding these values may cause permanent damage. Functional operation under these conditions is not implied.

* Voltages are with respect to ground (GND) unless otherwise stated

Recommended Operating Conditions*

	Characteristics	Sym.	Min.	Typ.	Max.	Units
1	Supply voltage 2.5 V mode	V_{DD25}	2.375	2.5	2.625	V
2	Supply voltage 3.3 V mode	V_{DD33}	3.135	3.3	3.465	V
3	Operating temperature	T_A	-40	25	85	°C

* Voltages are with respect to ground (GND) unless otherwise stated

DC Electrical Characteristics - Current Consumption

	Characteristics	Sym.	Min.	Typ.	Max.	Units	Notes
1	Supply current LVDS drivers - loaded (all outputs are active)	I_{dd_load}		61		mA	

DC Electrical Characteristics - Inputs and outputs - for 2.5/3.3 V supply

	Characteristics	Sym.	Min.	Typ.	Max.	Units	Notes
1	LVDS Differential input common mode voltage	V_{ICM}	1.1		1.6	V	for 2.5 V
2	LVDS Differential input common mode voltage	V_{ICM}	1.1		2.0	V	for 3.3 V
3	LVDS Differential input voltage	V_{ID}	0.25		1	V	
4	LVDS output differential voltage*	V_{OD}	0.25	0.30	0.40	V	
5	LVDS output common mode voltage	V_{CM}	1.1	1.25	1.375	V	

* The VOD parameter was measured from 125 to 750 MHz.



Figure 19 - Differential Voltage Parameter

AC Electrical Characteristics* - Inputs and Outputs (see Figure 20) - for 2.5/3.3 V supply.

	Characteristics	Sym.	Min.	Typ.	Max.	Units	Notes
1	Maximum Operating Frequency	1/t _p			750	MHz	
2	input to output clock propagation delay	t _{pd}	0	1	2	ns	
3	output to output skew	t _{out2out}		50	100	ps	
4	part to part output skew	t _{part2part}		80	300	ps	
5	Output clock Duty Cycle degradation	t _{PWH} / t _{PWL}	-5	0	5	Percent	
6	LVDS Output slew rate	r _{sl}	0.55			V/ns	

* Supply voltage and operating temperature are as per Recommended Operating Conditions

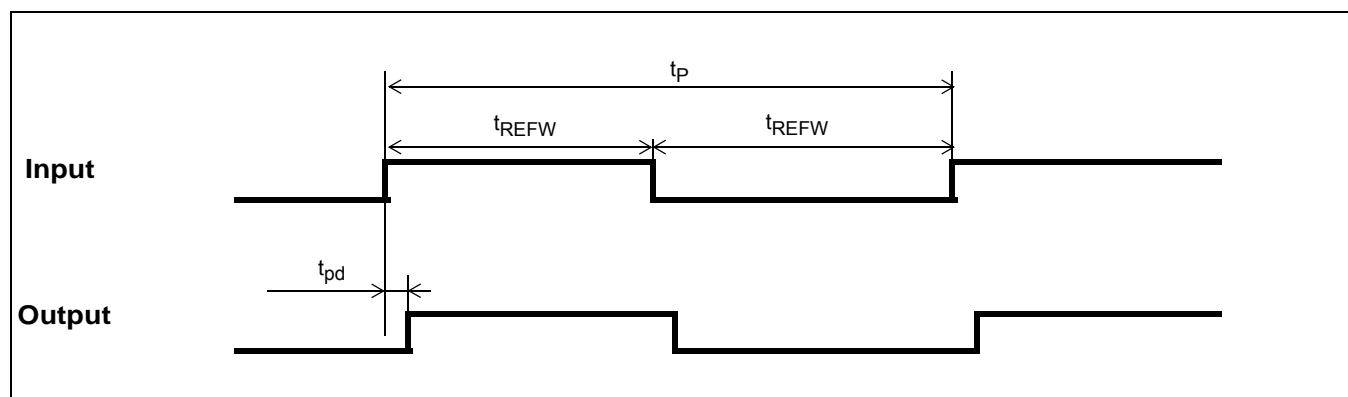

Figure 20 - Input To Output Timing

5.0 Performance Characterization

Additive Jitter at 2.5 V*

	Output Frequency (MHz)	Jitter Measurement Filter	Typical (fs)	Notes
1	125	12 kHz - 20 MHz	134	
2	212.5	12 kHz - 20 MHz	120	
3	311.04	12 kHz - 20 MHz	104	
4	425	12 kHz - 20 MHz	105	
5	500	12 kHz - 20 MHz	91	
6	622.08	12 kHz - 20 MHz	91	
7	750	12 kHz - 20 MHz	92	

*The values in this table were taken with an approximate slew rate of 0.8 V/ns.

Additive Jitter at 3.3 V*

	Output Frequency (MHz)	Jitter Measurement Filter	Typical (fs)	Notes
1	125	12 kHz - 20 MHz	132	
2	212.5	12 kHz - 20 MHz	122	
3	311.04	12 kHz - 20 MHz	106	
4	425	12 kHz - 20 MHz	106	
5	500	12 kHz - 20 MHz	94	
6	622.08	12 kHz - 20 MHz	92	
7	750	12 kHz - 20 MHz	93	

*The values in this table were taken with an approximate slew rate of 0.8 V/ns.

Additive jitter in the presence of power supply noise*

Carrier frequency	Parameter	Typical	Units	Notes
125	25 mV at 100 kHz	48	fs RMS	
750	25 mV at 100 kHz	53	fs RMS	

* The values in this table are the additive periodic jitter caused by an interfering tone typically caused by a switching power supply. For this test, measurements were taken over the full temperature and voltage range for $V_{DD} = 3.3$ V. The magnitude of the interfering tone is measured at the DUT.

6.0 Typical Behavior

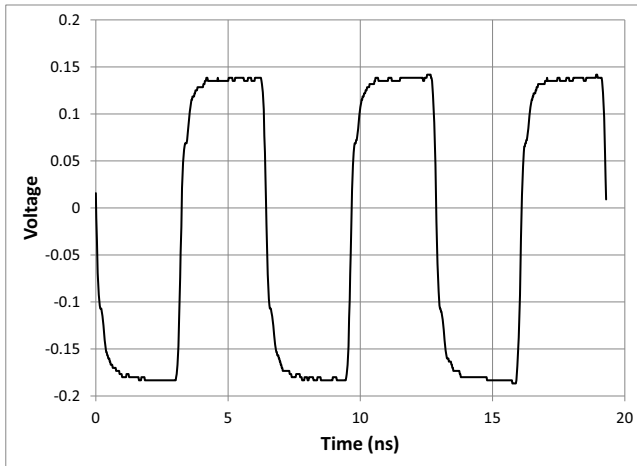

Typical Waveform at 155.52 MHz

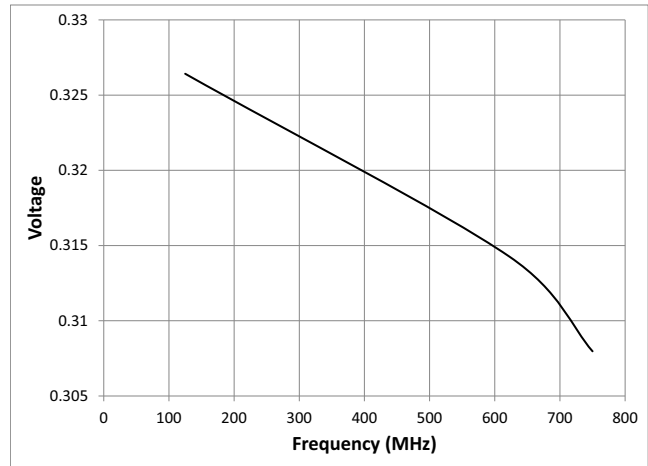

V_{OD} versus Frequency

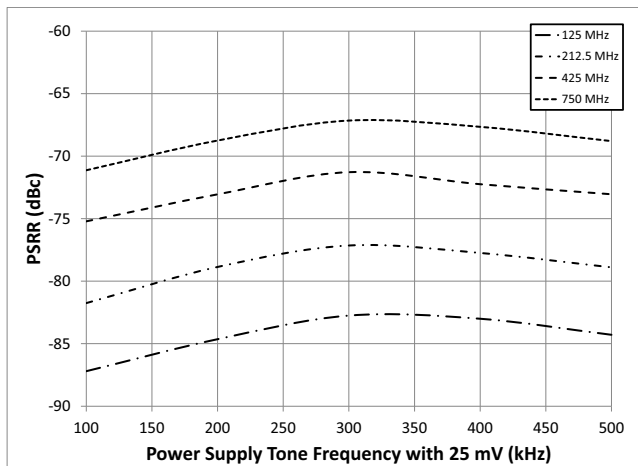

Power Supply Tone Frequency versus PSRR

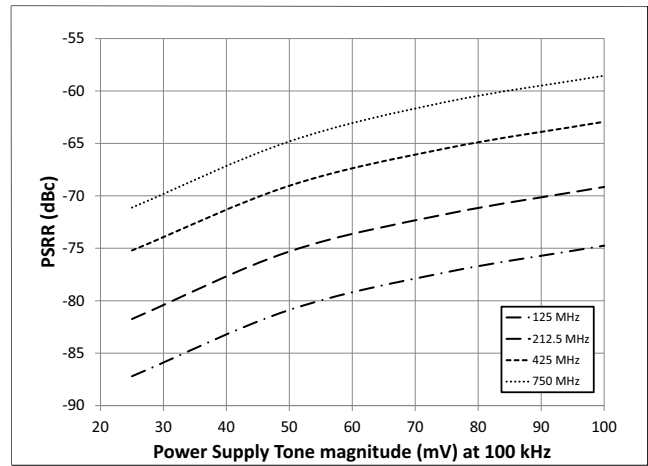

Power Supply Tone Magnitude versus PSRR

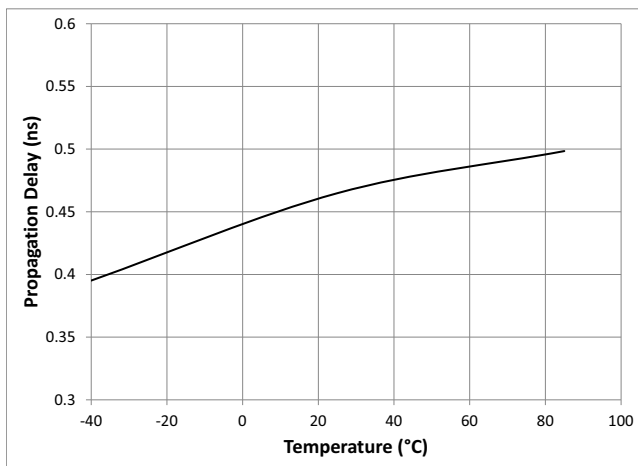

Propagation Delay versus Temperature

Note: This is for a single device. For more details see the characterization section.

7.0 Package Thermal Characteristics

Thermal Data

Parameter	Symbol	Test Condition	Value	Unit
Junction to Ambient Thermal Resistance	Θ_{JA}	Still Air	67.9	$^{\circ}\text{C}/\text{W}$
		1 m/s	61.6	
		2 m/s	58.1	
Junction to Case Thermal Resistance	Θ_{JC}	Still Air	44.1	$^{\circ}\text{C}/\text{W}$
Junction to Board Thermal Resistance	Θ_{JB}	Still Air	23.2	$^{\circ}\text{C}/\text{W}$
Maximum Junction Temperature*	T_{jmax}		125	$^{\circ}\text{C}$
Maximum Ambient Temperature	T_A		85	$^{\circ}\text{C}$

* Proper thermal management must be practiced to ensure that T_{jmax} is not exceeded.

8.0 Mechanical Drawing

