

ZSSC31010/ZSSC31015/ZSC31050/ZSSC3240

Mass Calibration System – Power Switch Board Version 1.0

The Power Switch Board (PSB) version 1.0 is useful for evaluating sensor modules (DUTs) using Renesas’s *MCB V2.0* mass calibration board, which have ZSC3xxx inside and are supplied by more than 5.5VDC. The PSB consists of a transistor switch stage, controlled by the multiplexed 5VDC power line of the MCB’s active DUT channel. All other pins of the DUT connector are short circuited on the PSB. Via the terminals K4 (not placed) and K5 a supply voltage of up to 40VDC can be connected. K4 and K5 terminals are internally protected against false polarity by diode D1. The diodes D2, D3, and D4 prevent the PSB module from unintended switching caused by feedback power via SDA and the internal ESD diodes of the ZSC3xxx. The customer can connect the DUT and the PSB via the solder pads of K3 or K6 (both terminals are not placed).

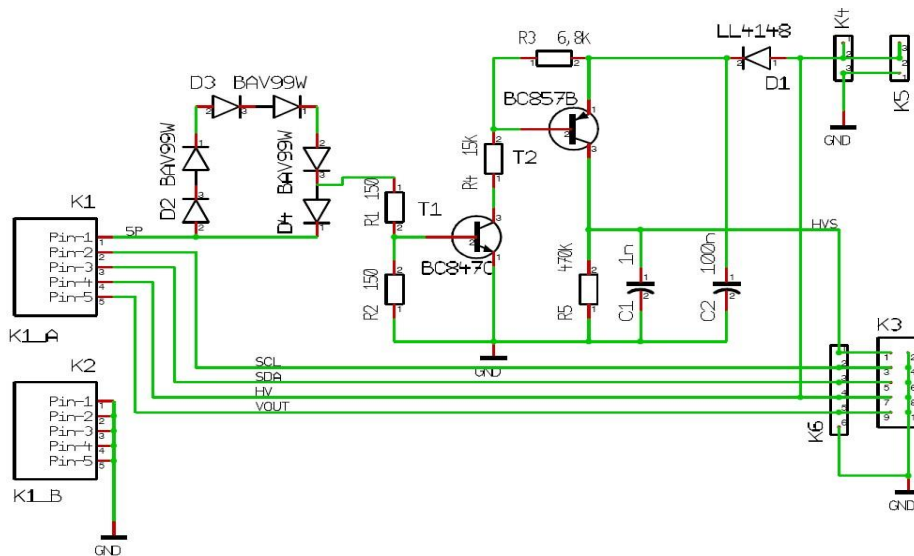

Figure 1. MCS – PSB: schematic

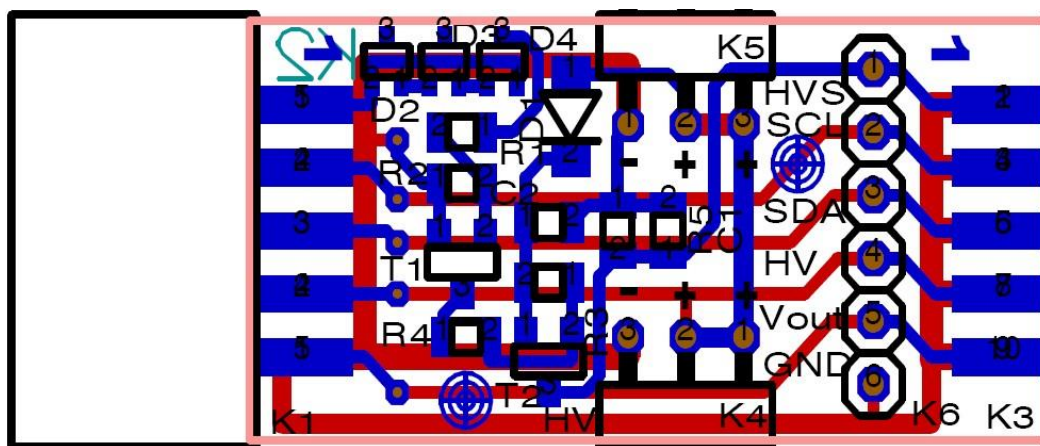

Figure 2. MCS – PSB: PCB layout

## Electrical Specifications (T = 25°C)

Signal	Name	Min	Max	Unit
5P	Multiplexed supply voltage of the activated DUT channel of the MCB	4.85	5.15	V DC
SCL	Clock signal of the I2C bus	not processed on the PSB		
SDA	Data signal of the I2C and the OWI/ZACwire bus	not processed on the PSB		
HV	High supply voltage connected via KL4/KL5 directly to K1 and K3 without switching	5.5	40	V DC
VOUT	Analog output voltage or OWI/ZACwire bus	not processed on the PSB		
HVS	Switched high supply voltage connected via KL4/KL5 and T2 to K3	5.5	40	V DC
I_5P	Load current of the MCB's DUT supply line when turning ON the HV switch		10	mA DC
I_HVS	Load current at HVS = ON = HV		50	mA DC
I_HV	Load current at HV		100	mA DC

## Ordering Information

Part Number	Package Description	Carrier Type	Temperature Range
ZMDIMCSPOWSWBDV1P0	PCB	Bag	-40 to 85°C

## Revision History

Revision	Date	Description
1.0	Sep 15, 2021	Initial release.