

Brief Description

The ZSSC3027 is a sensor signal conditioner (SSC) integrated circuit for high-accuracy amplification and analog-to-digital conversion of a differential input signal. Designed for high-resolution altimeter module applications, the ZSSC3027 can perform offset, span, and 1st and 2nd order temperature compensation of the measured signal. Developed for correction of resistive bridge sensors, it can also provide a corrected temperature output measured with an internal sensor.

The measured and corrected bridge values are provided at the digital output pins, which can be configured as I²C™* (≤ 3.4MHz) or SPI (≤ 20MHz). Digital compensation of signal offset, sensitivity, temperature, and non-linearity is accomplished via an 18-bit internal digital signal processor (DSP) running a correction algorithm. Calibration coefficients are stored on-chip in a highly reliable, non-volatile, multiple-time programmable (MTP) memory. Programming the ZSSC3027 is simple via the serial interface. The IC-internal charge pump provides the MTP programming voltage. The interface is used for the PC-controlled calibration procedure, which programs the set of calibration coefficients in memory.

The ZSSC3027 provides accelerated signal processing in order to support high-speed control, safety, and real-time sensing applications. It complements IDT's ZSSC30x6 products.

Features

- Flexible, programmable analog front-end design; up to 16-bit scalable, charge-balancing two-segment analog-to-digital converter (ADC)
- Fully programmable gain amplifier accepting sensors from 14 to 72 (linear factor)
- Internal auto-compensated temperature sensor
- Digital compensation of individual sensor offset; 1st and 2nd order digital compensation of sensor gain as well as of 1st and 2nd order temperature gain and offset drift
- Layout optimized for stacked-die bonding for high-density chip-on-board assembly
- Typical sensor elements can achieve accuracy of better than ±0.10% FSO** @ -40 to 85°C

Benefits

- Integrated 18-bit calibration math DSP
- Fully corrected signal at digital output
- One-pass calibration minimizes calibration costs
- No external trimming, filter, or buffering components required
- Highly integrated CMOS design
- Excellent for low-voltage and low-power battery applications
- Optimized for operation in calibrated resistive sensor modules

Physical Characteristics

- Supply voltage range: 1.7 to 3.6V
- Operating mode current consumption: 930µA (typical)
- Sleep State current: 20nA (typical)
- Temperature resolution: <0.003K/LSB
- Operation temperatures: -40°C to +85°C
- Small die size
- Delivery options: die for wafer bonding

Available Support

- ZSSC3026 Evaluation Kit can be used to evaluate ZSSC3027 capabilities
- Support Documentation

ZSSC3027 Application Example

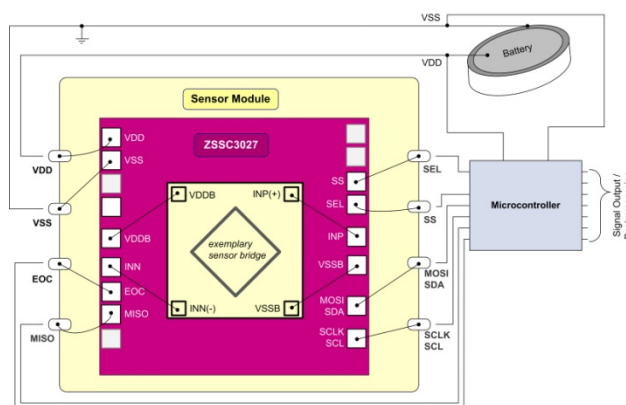

* I²C™ is a trademark of NXP.

** FSO = Full Scale Output.

**ZSSC3027
Block Diagram**

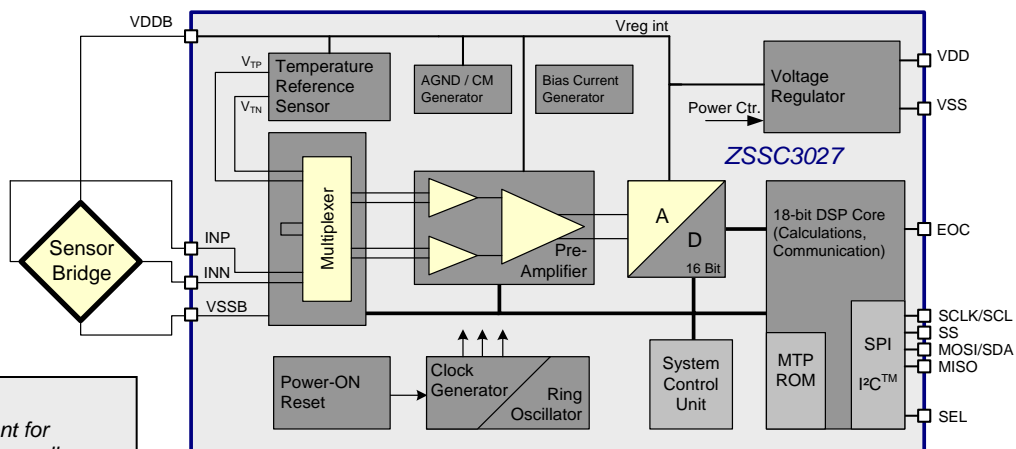

- Applications**
- ❖ Barometric altitude measurement for portable navigation or emergency call systems
 - ❖ Altitude measurement for car navigation
 - ❖ Inside hard disk pressure measurement
 - ❖ Weather forecast
 - ❖ Fan control
 - ❖ Industrial, pneumatic, and liquid pressure
 - ❖ High-resolution temperature measurements

Ordering Information (See section 6 in the data sheet for additional options for delivery)

Sales Code	Description	Delivery Package
ZSSC3027AC1B	Die—temperature range: -40°C to +85 °C	Wafer (304µm) unsawn, tested
ZSSC3027AC6B	Die—temperature range: -40°C to +85 °C	Wafer (725µm) unsawn, tested
ZSSC3027AC7B	Die—temperature range: -40°C to +85°C	Wafer (200µm) unsawn, tested
ZSSC3026-KIT	Evaluation Kit for ZSSC3026, including boards, cable, software, and 1 ZSSC3026 PQFN24 sample (equivalent to ZSSC3027—kit is recommended for evaluation of the capabilities of the ZSSC3027)	

Table of Contents

Table of Figures	4
List of Tables	5
1 IC Characteristics	6
1.1. Absolute Maximum Ratings	6
1.2. Operating Conditions	6
1.3. Electrical Parameters	7
1.4. Power Supply Rejection Ratio (RSRR) vs. Frequency.....	9
2 Circuit Description	10
2.1. Brief Description	10
2.2. Signal Flow and Block Diagram.....	10
2.3. Analog Front End.....	12
2.3.1. Amplifier	12
2.3.2. Analog-to-Digital Converter.....	13
2.3.3. Temperature Measurement	17
2.3.4. Bridge Supply.....	17
2.4. Digital Section.....	17
2.4.1. Digital Signal Processor (DSP) Core	17
2.4.2. MTP Memory.....	17
2.4.3. Clock Generator	18
2.4.4. Power Supervision	18
2.4.5. Interface	18
3 Functional Description.....	19
3.1. Power Up.....	19
3.2. Measurements.....	19
3.3. Operational Modes	19
3.4. Command Interpretation.....	21
3.4.1. SPI/I ² C™ Commands	21
3.5. Communication Interface.....	24
3.5.1. Common Functionality	24
3.5.2. SPI	25
3.5.3. I ² C™.....	28
3.6. Memory.....	29
3.6.1. Programming Memory	30

3.6.2.	Memory Status Commands	30
3.6.3.	Memory Contents.....	31
3.7.	Calibration Sequence	37
3.7.1.	Calibration Step 1 – Assigning Unique Identification	37
3.7.2.	Calibration Step 2 – Data Collection.....	37
3.7.3.	Calibration Step 3 – Coefficient Calculations.....	38
3.8.	The Calibration Math	39
3.8.1.	Bridge Signal Compensation	39
3.8.2.	Temperature Signal Compensation	42
4	Die Pad Assignments	43
5	Quality and Reliability.....	44
6	Ordering Sales Codes	44
7	Related Documents.....	45
8	Glossary	45
9	Document Revision History.....	46

Table of Figures

Figure 2.1	ZSSC3027 Functional Block Diagram	11
Figure 2.2	ADC Offset.....	16
Figure 3.1	Operational Flow Chart: Power Up	20
Figure 3.2	Operational Flow Chart: Command Mode and Normal Mode	21
Figure 3.3	SPI Configuration CPHA=0	25
Figure 3.4	SPI Configuration CPHA=1	26
Figure 3.5	SPI Command Request	26
Figure 3.6	SPI Read Status	27
Figure 3.7	SPI Read Data	27
Figure 3.8	I ² C™ Command Request	28
Figure 3.9	I ² C™ Read Status.....	28
Figure 3.10	I ² C™ Read Data	29
Figure 3.11	Memory Program Operation	30
Figure 4.1	ZSSC3027 Pad Assignments	43

List of Tables

Table 1.1	Maximum Ratings	6
Table 1.2	Operating Conditions	6
Table 1.3	Requirements for VDD Power-on Reset.....	7
Table 1.4	Electrical Parameters.....	7
Table 2.1	Amplifier Gain: Stage 1	12
Table 2.2	Amplifier Gain: Stage 2.....	12
Table 2.3	Gain Polarity	13
Table 2.4	MSB/LSB Segmentation Settings for Bridge Measurement.....	14
Table 2.5	MSB/LSB Segmentation Settings for Temperature Measurement.....	14
Table 2.6	ADC Conversion Times for a Single A2D Conversion.....	14
Table 2.7	Typical Conversion Times vs. Noise Performance for 16-Bit Results with Full Sensor Signal Conditioning for AZBM, BM, AZTM, and TM.....	15
Table 2.8	ADC Offset Settings for the Measurement Configuration Register BM_config	16
Table 3.1	SPI/I ² C™ Commands	22
Table 3.2	Get_Raw Commands	23
Table 3.3	General Status Byte.....	24
Table 3.4	Status Byte for Read Operations	24
Table 3.5	Status Byte for Write Operations	24
Table 3.6	Mode Status.....	25
Table 3.7	Memory Status Word.....	30
Table 3.8	MTP Memory Content Assignments.....	31
Table 4.1	Pad Assignments.....	43

1 IC Characteristics

1.1. Absolute Maximum Ratings

Note: The absolute maximum ratings are stress ratings only. The ZSSC3027 might not function or be operable above the recommended operating conditions. Stresses exceeding the absolute maximum ratings might also damage the device. In addition, extended exposure to stresses above the recommended operating conditions might affect device reliability. IDT does not recommend designing to the “Absolute Maximum Ratings.”

Table 1.1 Maximum Ratings

PARAMETER	SYMBOL	Min	TYP	MAX	UNITS
Voltage Reference	V _{SS}	0		0	V
Analog Supply Voltage	V _{DD}	-0.4		3.63	V
Voltage at all Analog and Digital IO Pins	V _{A_IO} , V _{D_IO}	-0.5		V _{DD} +0.5	V
Input Current into any Pin Except SDA, CLK ¹⁾ and Supply Pins ²⁾	I _{IN}	-100		100	mA
Electrostatic Discharge Tolerance – Human Body Model (HBM1) ³⁾	V _{HBM1}	4000		-	V
Storage Temperature	T _{STOR}	-50		125	°C

1) Latch-up current limit for SCLK/SCL and MOSI/SDA: ±70mA.
 2) Latch-up resistance; reference for pin is 0V.
 3) HBM1: C = 100pF charged to V_{HBM1} with resistor R = 1.5kΩ in series based on MIL 883, Method 3015.7. ESD protection referring to the Human Body Model is tested with devices in ceramic dual in-line packages (CDIP) during product qualification.

1.2. Operating Conditions

The reference for all voltages is V_{SS}.

Table 1.2 Operating Conditions

PARAMETER	SYMBOL	MIN	TYP	MAX	UNIT
Supply Voltage	V _{DD}	1.7	-	3.6	V
VDD Rise Time	t _{VDD}			200	μs
Bridge Current	I _{VDDB}			1.8	mA
				16.5	
Operation Temperature Range—Standard	T _{AMB}	-40	-	85	°C
External capacitance between VDDDB and VSS	CL	0.01		50	nF

A dynamic power-on-reset circuit is implemented in order to achieve minimum current consumption in idle mode. The VDD low level and the subsequent rise time and VDD rising slope must meet the requirements in Table 1.1 to guarantee an overall IC reset; lower VDD low levels allow slower rising of the subsequent on-ramp of VDD. Other combinations might also be possible. For example, the reset trigger can be influenced by increasing the power-down time and lowering the VDD rising slope requirement.

Table 1.3 Requirements for VDD Power-on Reset

PARAMETER	SYMBOL	MIN	TYP	MAX	UNIT
Power Down Time (duration of VDD Low Level)	t_{SPIKE}	3	-	-	μs
VDD Low Level	$V_{DD_{low}}$	0	-	0.2	V
VDD Rising Slope	SR_{VDD}	10	-	-	V/ms

1.3. Electrical Parameters

All parameter values are valid only under the specified operating conditions. All voltages are referenced to Vss.

Table 1.4 Electrical Parameters

Note: See important table notes at the end of the table.

Parameter	Symbol	Conditions/Comments	Min	Typ	Max	Unit
Supply						
Bridge Supply Voltage, ADC Reference Voltage	V_{DDB}	Internally generated	1.60	1.67	1.74	V
Current Consumption	I_{VDD}	Active State, average		930	1500	μA
		Sleep State, idle current		20	250	nA
Power Supply Rejection $20 \cdot \log_{10}(V_{DD}/V_{DDB})$ (see section 1.4)	PSR_{VDD}	$V_{DD} = 1.8V$	17			dB
		$V_{DD} = 2V$	32			dB
Memory Program Voltage	$V_{DD,prog}$	Required voltage level at VDD pin	2.9		3.6	V
Mean Program Current	$I_{VDD,prog}$	Mean current consumption during multiple-time memory (MTP) programming cycle at VDD	6			mA
Peak Program Current	$I_{prog,max}$	MTP program at VDD pin, dynamic switch-on current draw			20	mA

Parameter	Symbol	Conditions/Comments	Min	Typ	Max	Unit
Analog-to-Digital Converter (ADC, A2D)						
Resolution	r_{ADC}		10		16	Bit
ADC Clock Frequency	f_{ADC}	Internal ADC clock	0.92	1	1.08	MHz
Reference Voltage n	V_{refn}	See section 2.3.2.		V_{DDB} * 0.03		
Reference Voltage p	V_{refp}	See section 2.3.2.		V_{DDB} * 0.97		
Offset	A2D_Offset	8-step programmable offset	1/16		8/16	
Integral Nonlinearity (INL)	INL _{ADC}	Tested / verified within design	-4	-	+4	LSB
Differential Nonlinearity	DNL _{ADC}	Tested / verified within design	-1	-	+1	LSB
Conversion Rate, 16-Bit Single	$f_{s,raw}$	Conversions per second for single 16-bit A2D conversion	6	-	355	Hz
Amplifier						
Gain	G_{amp}	32 steps	13.2		72	
Gain Error	G_{err}	Referenced to nominal gain	-2.5	-	2.5	%
Sensor Signal Conditioning Performance						
IC Accuracy Error ¹⁾	Err _{A,IC}	Accuracy error for ideally linear sensor (temperature and measurand)			0.01	%FSO
Conversion Rate, 16-Bit SSC	$f_{s,SSC}$	Conversion per second for fully corrected 16-bit measurement	3		175	Hz
Input						
Input Voltage Range	V_{INP}, V_{INN}	Input voltage range at INP and INN	0.65		1.05	V
Bridge Resistance	R_{BR}	Full power supply disturbance rejection (PSRR) capabilities	1	10	50	k Ω
		Reduced PSRR, but full functionality	100		999	Ω
Power-Up						
Start-up Time	t_{STA1}	V_{DD} ramp up to interface communication (see section 3.1)			1	ms
	t_{STA2}	V_{DD} ramp up to analog operation			2.5	ms
Wake-up Time	t_{WUP1}	Sleep to Active State interface communication			0.5	ms
	t_{WUP2}	Sleep to Active State analog operation			2	ms
Oscillator						
Internal Oscillator Frequency	f_{CLK}		3.7	4	4.3	MHz

Parameter	Symbol	Conditions/Comments	Min	Typ	Max	Unit
Internal Temperature Sensor						
Temperature Resolution		For both temperature ranges: -40°C to +85°C		0.003		K/LSB
Interface and Memory						
SPI Clock Frequency	$f_{C,SPI}$	Maximum capacitance at MISO line: 40pF @ $V_{DD}=1.8V$			20	MHz
I ² C™ Clock Frequency	$f_{C,I2C}$				3.4	MHz
Program Time	t_{prog}	MTP programming time per 16-bit register	500		600	μs
Data Retention ²⁾	t_{RET_MTP}	1000h @ 125°C	10			a
1) Percentage referred to maximum full-scale output (FSO); e.g. for 16-bit measurements: $Err_{A,IC}[\%FSO] = 100 \cdot \text{MAX}\{ ADC_{meas} - ADC_{ideal} \} / 2^{16}$. 2) With maximum ambient temperature of 125°C.						

1.4. Power Supply Rejection Ratio (RSRR) vs. Frequency

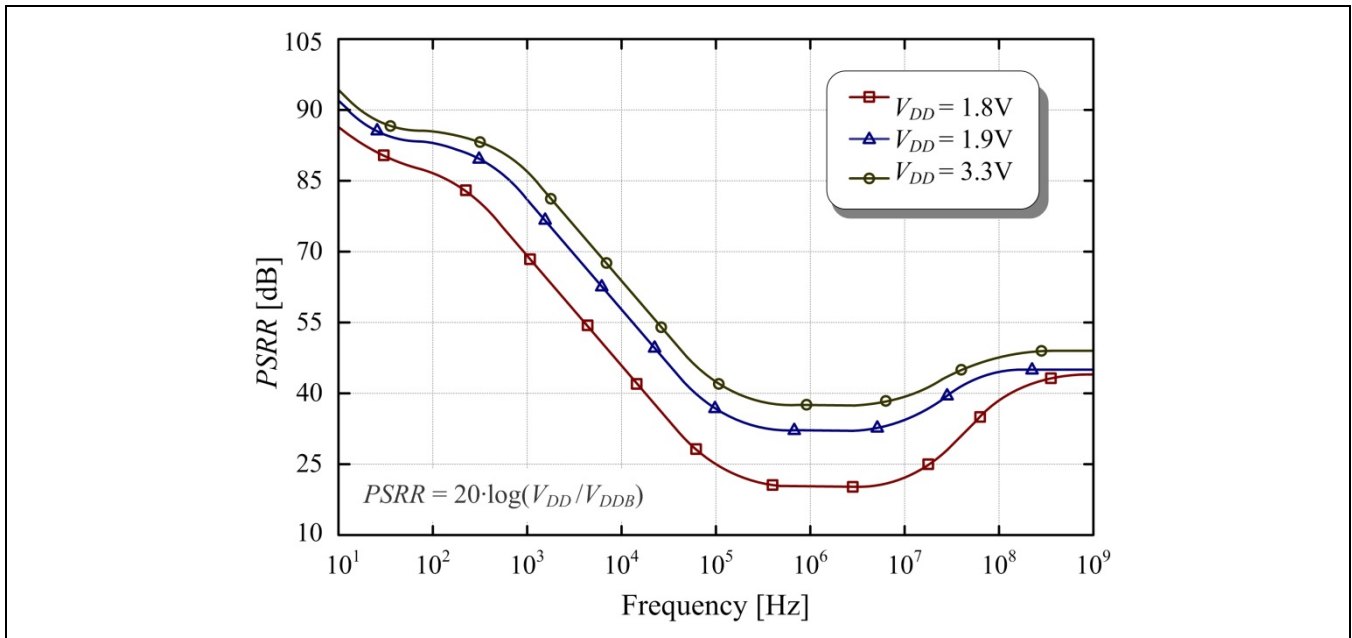

2 Circuit Description

2.1. Brief Description

The ZSSC3027 provides a highly accurate amplification of bridge sensor signals. The compensation of sensor offset, sensitivity, temperature drift, and non-linearity is accomplished via an 18-bit DSP core running a correction algorithm with calibration coefficients stored in a multiple-time programmable (MTP) memory (see section 2.4.2 regarding limitations). The ZSSC3027 can be configured for a wide range of resistive bridge sensor types. A digital interface (SPI or I²C™*) enables communication. The ZSSC3027 supports two operational modes: Normal Mode and Command Mode. Normal Mode is the standard operating mode. Typically in Normal Mode, the ZSSC3027 wakes up from a Sleep State (low power), runs a measurement in Active State, and automatically returns to the Sleep State. (See section 3.3 for details on operational modes.)

2.2. Signal Flow and Block Diagram

See Figure 2.1 for the ZSSC3027 block diagram. The sensor bridge supply V_{DDB} and the power supply for analog circuitry are provided by a voltage regulator, which is optimized for power supply disturbance rejection (PSRR). See section 1.4 for a graph of PSRR versus frequency. To improve noise suppression, the digital blocks are powered by a separate voltage regulator. A power supervision circuit monitors all supply voltages and generates appropriate reset signals for initializing the digital blocks.

The state machine controls the analog circuitry to perform the three measurement types: bridge, temperature, and offset measurement. The multiplexer selects the signal input to the amplifier, which can be the external signals from the input pins INP and INN, the internal temperature reference sensor signals, or an input short for measuring offset. A full measurement request will trigger an automatic sequence of all measurement types and all input signals. The Temperature Reference Sensor block is based on a resistive sensing element.

* I²C™ is a trademark of NXP.

Figure 2.1 ZSSC3027 Functional Block Diagram

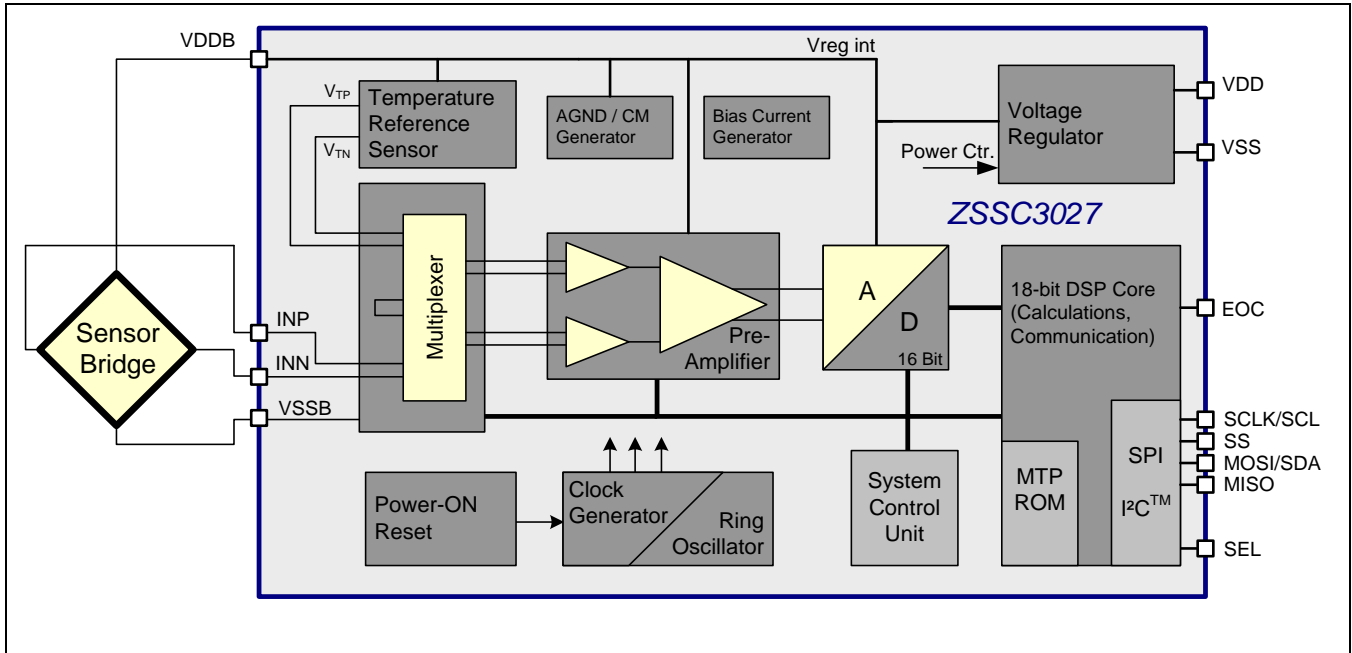

The amplifier consists of two stages with programmable gain values. The $1/f$ noise and inherent offset are suppressed by auto-zero and chopper stabilizer techniques. This auto-zero sequence is performed before each bridge sensor and temperature measurement to compensate for the inherent offset of the amplifier.

The ZSSC3027 employs a 2-stage analog-to-digital converter (ADC) based on switched-capacitor technique with inherent low-pass behavior and noise suppression. The programmable resolution from 10 to 16 bits provides flexibility for adapting the conversion characteristics. To improve power supply noise suppression, the ADC uses the bridge supply V_{DDB} as its reference voltage.

The remaining IC-internal offset and the sensor element offset, i.e., the overall system offset for the amplifier and ADC, can be canceled by an offset and auto-zero measurement, respectively.

The DSP accomplishes the auto-zero, span, and 1st and 2nd order temperature compensation of the measured bridge signal. The correction coefficients are stored in the MTP memory.

The ZSSC3027 supports SPI and I²C™ interface communication for controlling the ZSSC3027, configuration, and measurement result output.

2.3. Analog Front End

2.3.1. Amplifier

The amplifier has a differential architecture and consists of two stages. The amplification of each stage and the sensor bridge gain polarity are programmable via settings in the Measurement Configuration Register *BM_config* (address 10_{HEX}; see section 3.6.3) in the MTP memory (see section 2.4.2). The first five bits of *BM_config* are the programmable gain settings *Gain_stage1* and *Gain_stage2*. The options for the programmable gain settings are listed in Table 2.1 and Table 2.2.

Table 2.1 Amplifier Gain: Stage 1

<i>Gain_stage1</i>		
<i>BM_config</i> Bit G1	<i>BM_config</i> Bit G0	Stage 1 Gain Setting
0	0	12
0	1	20
1	0	30
1	1	40

Table 2.2 Amplifier Gain: Stage 2

<i>Gain_stage2</i>			
<i>BM_config</i> Bit G4	<i>BM_config</i> Bit G3	<i>BM_config</i> Bit G2	Stage 2 Gain Setting
0	0	0	1.1
0	0	1	1.2
0	1	0	1.3
0	1	1	1.4
1	0	0	1.5
1	0	1	1.6
1	1	0	1.7
1	1	1	1.8

If needed, the polarity of the sensor bridge gain can be reversed by setting the *Gain_polarity* bit, which is bit 5 in the *BM_config* register (see section 3.6.3). Changing the gain polarity is achieved by inverting the chopper clock. Table 2.3 gives the settings for the *Gain_polarity* bit. This feature enables applying a sensor to the ZSSC3027 with swapped input signals at INN and INP; e.g., to avoid crossing wires for the final sensor module's assembly.

Table 2.3 Gain Polarity

Gain_polarity (BM_config Bit 5)	Gain	Setting Description
0	+1	No polarity change.
1	-1	Gain polarity is inverted.

The inherent amplifier offset is suppressed by means of auto-zero and chopper techniques. The optimal gain (and offset) setup for a specific sensor element can be determined by these steps:

- 1) Collect sensor elements' characteristic, statistical data (over temperature, ambient sensor parameter, and over production tolerances):
 - a. Minimum differential output voltage: V_{min}
 - b. Maximum differential output voltage: V_{max}

Note: The best possible setup can only be determined if the absolute value of V_{max} is bigger than the absolute value of V_{min} . If this is not the case, the gain polarity should be reversed.

- 2) If V_{min} and V_{max} have different signs (normally: V_{max} is positive and V_{min} is negative), then the required ADC offset shift can be selected using this ratio: $Ratio_{Offset} = |V_{min}| / (V_{max} - V_{min})$.

In this case, the respective offset setup (A2D_offset) is the nearest integer of multiples of 1/16 in the range of 1/16 to 8/16 (see Table 2.8): $A2D_offset = Round_to_x16^{th}\{Ratio_{Offset}\}$.

- 3) Determine which of the two following cases is valid.

- a. If $Ratio_{Offset} - A2D_offset \leq 0$ then calculate
Theoretical optimum gain: $Gain_{opt} = (1 - A2D_offset) * V_{ref} / V_{max}$

- b. If $Ratio_{Offset} - A2D_offset > 0$ then calculate
Theoretical optimum gain: $Gain_{opt} = A2D_offset * V_{ref} / |V_{min}|$

$$\text{with: } V_{ref} = V_{refp} - V_{refn} = 0.94 \cdot V_{DDB,min} \approx 1.5V$$

Finally, select the setup gain ($Gain_{setup}$) as the nearest gain to $Gain_{opt}$, where $Gain_{setup} \leq Gain_{opt}$.

2.3.2. Analog-to-Digital Converter

A second-order charge-balancing analog-to-digital converter (ADC) is used to convert the amplifier signal. To allow optimizing the trade-off between conversion time and resolution, the conversion is split into a MSB coarse conversion and an LSB fine conversion. The final ADC resolution is determined by MSB + LSB. For the bridge measurement, the MSB-LSB segmentation is programmable via the *Msb* and *Lsb* settings in the *BM_config* register (10_{HEX}; see section 3.6.3) stored in the MTP memory (see section 2.4.2). For the temperature measurement, the MSB-LSB segmentation is programmable via the *Temp_ADC* settings in the *BM_config* register.

The conversion time is proportional to $2^{MSB} + 2^{LSB}$. During the MSB coarse conversion, the ADC input signal is sampled and integrated 2^{MSB} times, resulting in inherit low-pass behavior and noise suppression. The longer the MSB coarse conversion is, the better the noise suppression is. Possible settings are listed below in Table 2.4 and Table 2.5.

Table 2.4 MSB/LSB Segmentation Settings for Bridge Measurement

<i>Msb Setup Bits [7:6] in BM_config</i>	<i>Number of MSB Coarse Conversion Bits</i>	<i>Lsb Setup Bits [9:8] in BM_config</i>	<i>Number of LSB Fine Conversion Bits</i>
00 _{BIN}	10	00 _{BIN}	0
01 _{BIN}	12	01 _{BIN}	2
10 _{BIN}	14	10 _{BIN}	4
11 _{BIN}	16	11 _{BIN}	6

Table 2.5 MSB/LSB Segmentation Settings for Temperature Measurement

<i>Temp_ADC Setup Bits [14:13] in BM_config</i>	<i>Number of MSB Coarse Conversion Bits</i>	<i>Number of LSB Fine Conversion Bits</i>
01 _{BIN}	16	0
10 _{BIN}	10	6
11 _{BIN}	12	4
00 _{BIN}	Setup according to IDT configuration in reserved memory (recommended setup for best performance and speed trade-off)	

Table 2.6 gives the ADC conversion times for the MSB/LSB settings (yellow indicates 16-bit setups). Useful MSB/LSB setups are with LSB = 0 (MSB-only conversions) or combinations that result in MSB + LSB ≤ 16. Resolutions beyond 16-bit mainly digitize the collected front-end noise and typically do not improve the system performance.

Table 2.6 ADC Conversion Times for a Single A2D Conversion

MSB [Bits]	LSB [Bits]	Bridge or Temperature Measurement Conversion Time in μs (typical)
10	0	1170
12	0	4625
14	0	18450
16	0	73745
10	2	1180
12	2	4635
14	2	18460
10	4	1200
12	4	4660
10	6	1300

Table 2.7 shows the trade-off between noise performance and typical conversion time for 16-bit results for a signal that has been fully conditioned using 4 single measurements: the auto-zero bridge measurement (AZBM), the bridge measurement (BM), auto-zero temperature measurement (AZTM), and temperature measurement (TM).

Table 2.7 Typical Conversion Times vs. Noise Performance for 16-Bit Results with Full Sensor Signal Conditioning for AZBM, BM, AZTM, and TM

Note: The pink shading indicates IDT's recommended ADC segmentation for temperature sensor measurement.

ADC Segmentation: Temperature Sensor [MSB/LSB]	ADC Segmentation: Bridge Sensor [MSB/LSB]	Typical Measurement Duration, MEASURE, (AC _{HEX}) [ms]	Typical 3-Sigma Noise for SSC-Corrected Output ¹⁾ [counts]
10 / 6	10 / 6	5.8	9.6
10 / 6	12 / 4	13.2	7.4
10 / 6	14 / 2	43.0	6.8
10 / 6	16 / 0	165	6.6
12 / 4	10 / 6	13.2	9.5
12 / 4	12 / 4	20.5	7.3
12 / 4	14 / 2	50.5	6.7
12 / 4	16 / 0	170.3	6.3
16 / 0	10 / 6	162.6	8.1
16 / 0	12 / 4	170.3	6.6
16 / 0	14 / 2	200.3	5.3
16 / 0	16 / 0	319.5	5.2

1) Reference noise values were obtained with this setup: 17kΩ sensor bridge, 25°C, Gain=54, ADC shift=-1/16 through 15/16 (see below), VDD=1.8V.

The ADC offset is programmable in 8 steps so that the ADC input voltage range can be adapted to the voltage range at the input pins INP and INN. Possible ADC input voltages and references voltages V_{refn} and V_{refp} are shown in Figure 2.2, where $V_{AGND} \approx V_{DDB}/2$. The ADC offset is controlled by the *A2D_Offset* setting bits [12:10] in the Measurement Configuration Register *BM_config* (10_{HEX}; see section 3.6.3) in the MTP memory (see section 2.4.2). The ADC offset settings are listed in Table 2.8. See section 1.4 for typical values for V_{refn} and V_{refp} .

Figure 2.2 ADC Offset

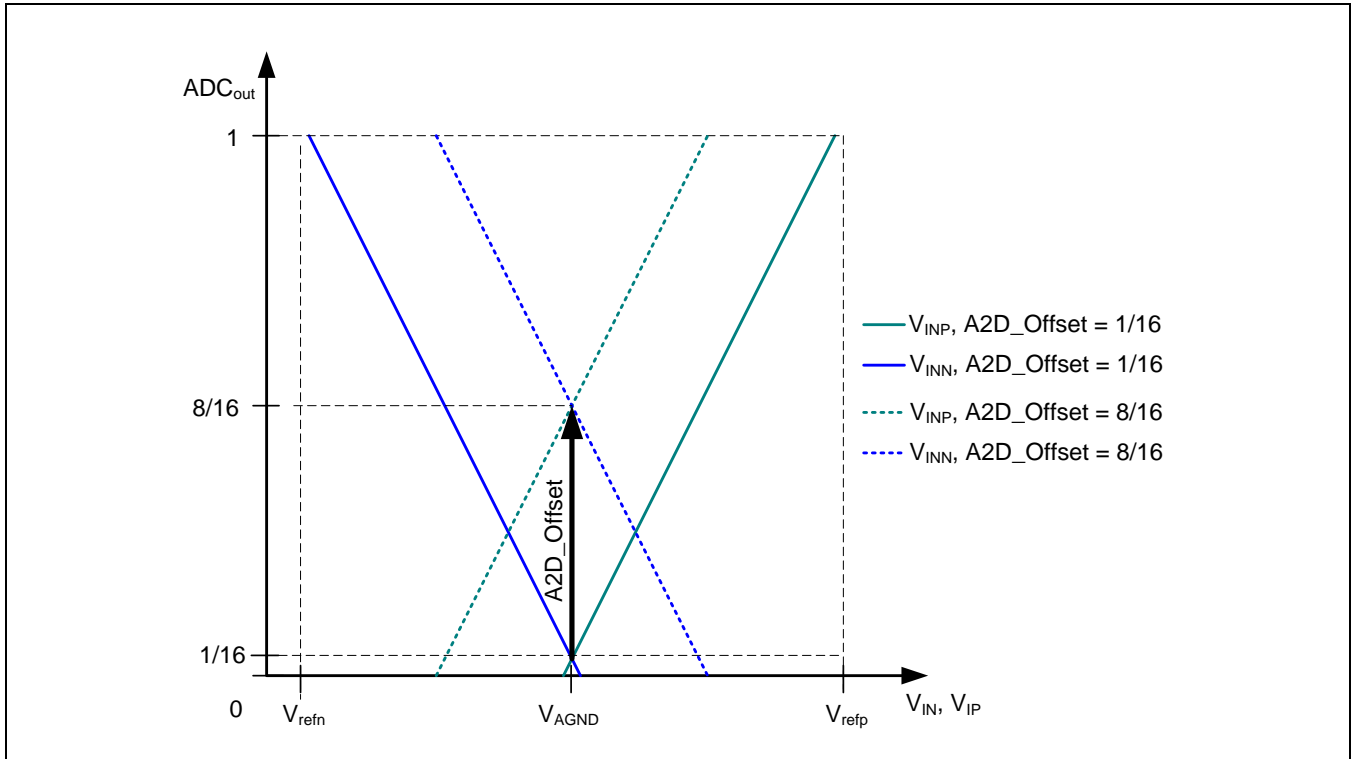

Table 2.8 ADC Offset Settings for the Measurement Configuration Register BM_config

Z2 (BM_config bit 12)	Z1 (BM_config bit 11)	Z0 (BM_config bit 10)	ADC Differential Input Range/ V_{ref} Where $V_{ref} = V_{refp} - V_{refn}$	A2D_Offset
0	0	0	-1/16 to 15/16	1/16
0	0	1	-2/16 to 14/16	2/16
0	1	0	-3/16 to 13/16	3/16
0	1	1	-4/16 to 12/16	4/16
1	0	0	-5/16 to 11/16	5/16
1	0	1	-6/16 to 10/16	6/16
1	1	0	-7/16 to 9/16	7/16
1	1	1	-8/16 to 8/16	8/16

2.3.3. Temperature Measurement

The ZSSC3027 provides an internal temperature sensor measurement to allow compensation for temperature effects. See section 1.3 for the temperature sensor resolution. The temperature sensor uses bipolar transistors. Any transistor circuitry mismatch is suppressed by the dynamic element matching technique. The temperature output signal is a differential voltage that is adapted by the amplifier for the ADC input.

For temperature measurements, the ADC offset and amplifier gain setting are defined by IDT. The ADC MSB/LSB segmentation is programmable by the user for optimizing noise immunity or conversion time (see section 2.3.2).

2.3.4. Bridge Supply

The ZSSC3027 provides dedicated bridge supply pins V_{DDB} and V_{SSB}. The ADC reference voltages for the sensor bridge measurement are derived from these internal voltages so that bridge supply disturbances are suppressed. The current drive ability of V_{DDB} is limited (see I_{V_{DDB}} in section 1.2).

2.4. Digital Section

2.4.1. Digital Signal Processor (DSP) Core

The DSP Core block performs the algorithm for correcting the sensor signal. The resulting coefficients are stored in the MTP memory. When the measurement results are available, the "end of conversion" signal is set at the EOC pin. The internal EOC information is valid only if both the measurement and calculation have been completed.

2.4.2. MTP Memory

The ZSSC3027's memory is designed with an OTP (one-time programmable) structure. The memory is organized in 4 one-time programmable pages. When data in the currently valid memory page needs to be updated, normally a new page must be selected by increasing the page counter and the whole memory content must be written in its updated version. The user has access to a 24 x 16 bit storage area for values such as calibration coefficients. Dedicated calibration values are stored in an area not accessible to the user. The required programming voltage is generated internally in the ZSSC3027 whereas increased ZSSC3027 power supply requirements must be fulfilled during programming (see Memory Programming Voltage in section 1.3). There is no over-write or erase function for the MTP memory. See section 3.4.1 for further details.

The physical memory function is such that each single bit that has not yet been set to 1 (i.e., remains 0) can still be changed to 1, so it is possible to (partially) re-program an MTP register as shown in the following example:

- Assume MTP address 11_{HEX} was written with 8421_{HEX} which is 1000 0100 0010 0001_{BIN}.
- Changing the register contents to A6A7_{HEX} (i.e., 1010 0110 1010 0111_{binary}) can be achieved by either writing A6A7_{HEX} (any already written bit will be ignored automatically) or just writing the difference compared to 8421_{HEX}, which is 2286_{HEX}.

The content of a re-written register can generally be determined by

$$\text{content}_{\text{Register}} = \text{content}_{\text{old}} (\text{BITWISE_OR}) \text{content}_{\text{new}}$$

If $\text{content}_{\text{Register}}$ equals $\text{content}_{\text{new}}$, a re-write is possible; e.g., this is not the case for $\text{content}_{\text{old}} = \text{FFFF}_{\text{HEX}}$ and $\text{content}_{\text{new}} \neq \text{FFFF}_{\text{HEX}}$. Depending on the former and the newly intended MTP addresses and register contents, a re-programming could be possible.

2.4.3. Clock Generator

The clock generator, implemented as a ring oscillator, provides a 4MHz clock signal. The frequency is trimmed during production test.

2.4.4. Power Supervision

The power supervision block as a part of the voltage regulator combined with the digital section monitors all power supplies to ensure a defined reset of all digital blocks during power-up or power supply interruptions.

2.4.5. Interface

The ZSSC3027 can communicate with the user's PC via an SPI or I²C™ interface †. The interface type is selectable via the voltage level on the SEL pin:

- SEL = 0 -> SPI Mode
- SEL = 1 -> I²C™ Mode

If the SEL pin is not connected, I²C™ communication will be selected (IC-internal pull-up at SEL pin). The SPI-specific pins (SS, MISO) do not need to be connected for I²C™ operation.

To also provide interface accessibility in Sleep State (all features inactive except for the digital interface logic), the interface circuitry is directly supplied by VDD.

† Functional I²C™ interface properties correspond to the NXP I²C™ bus specification Rev. 0.3 (June 2009).

3 Functional Description

3.1. Power Up

Specifications for this section are given in sections 1.2 and 1.3. On power-up, the ZSSC3027 communication interface is able to receive the first command after a time t_{STA1} from when the VDD supply is within operating specifications. The ZSSC3027 can begin the first measurement after a time of t_{STA2} from when the VDD supply is operational. The wake up time from Sleep State to Active State (see section 3.3) after receiving the activating command is defined as t_{WUP1} and t_{WUP2} (see section 1.3). In Command Mode, subsequent commands can be sent after t_{WUP1} . The first measurement starts after t_{WUP2} if a measurement request was sent.

3.2. Measurements

Available measurement procedures are

- AZBM: auto-zero bridge measurement
- BM: bridge measurement
- AZTM: auto-zero temperature measurement
- TM: temperature measurement

AZBM: The configuration for bridge measurements is loaded. The Multiplexer block connects the amplifier input to the AGND analog ground reference. An analog-to-digital conversion is performed so that the inherent system offset for the bridge configuration is converted by the ADC to a 16-bit digital word.

BM: The configuration for bridge measurements is loaded. The Multiplexer connects the amplifier input to the bridge pins INP and INN. An analog-to-digital conversion is performed. The result is a 16-bit digital word.

AZTM: The configuration for temperature measurements is loaded. The Multiplexer connects the amplifier input to AGND. An analog-to-digital conversion is performed so that the inherent system offset for the temperature configuration is converted by the ADC to a 16-bit digital word.

TM: The configuration for temperature measurements is loaded. The Multiplexer connects the Amplifier input to the internal temperature sensor. An analog-to-digital conversion is performed. The result is a 16-bit digital word.

The typical application's measurement cycle is a complete SSC measurement (using the command AC_{HEX}) with AZBM, BM, AZTM, and TM followed by a signal correction calculation.

3.3. Operational Modes

Figure 3.1 illustrates the ZSSC3027 power-up sequence and subsequent operation depending on the selected interface communication mode (I^2C^{TM} or SPI) as determined by the SEL pin voltage level (see section 2.4.5). With either interface, after the voltage regulators are switched on, the ZSSC3027's low voltage section (LV) is active while the related interface configuration information is read from memory. Then the LV section is switched off, the ZSSC3027 goes into Sleep State, and the interface is ready to receive commands. Since the interface is always powered by V_{DD} , it is referred to as the high voltage section (HV).

See Table 3.1 for definitions of the commands. Figure 3.2 shows the ZSSC3027 operation in Normal Mode and Command Mode including when the LV and HV sections are active as indicated by the color legend.

The Normal Mode automatically returns to Sleep State after executing the requested measurements. In Command Mode, the ZSSC3027 remains active if a dedicated command (Start_NOM) was sent, which is helpful during calibration. Command Mode can only be entered if Start_CM is the first command received after POR.

Figure 3.1 Operational Flow Chart: Power Up

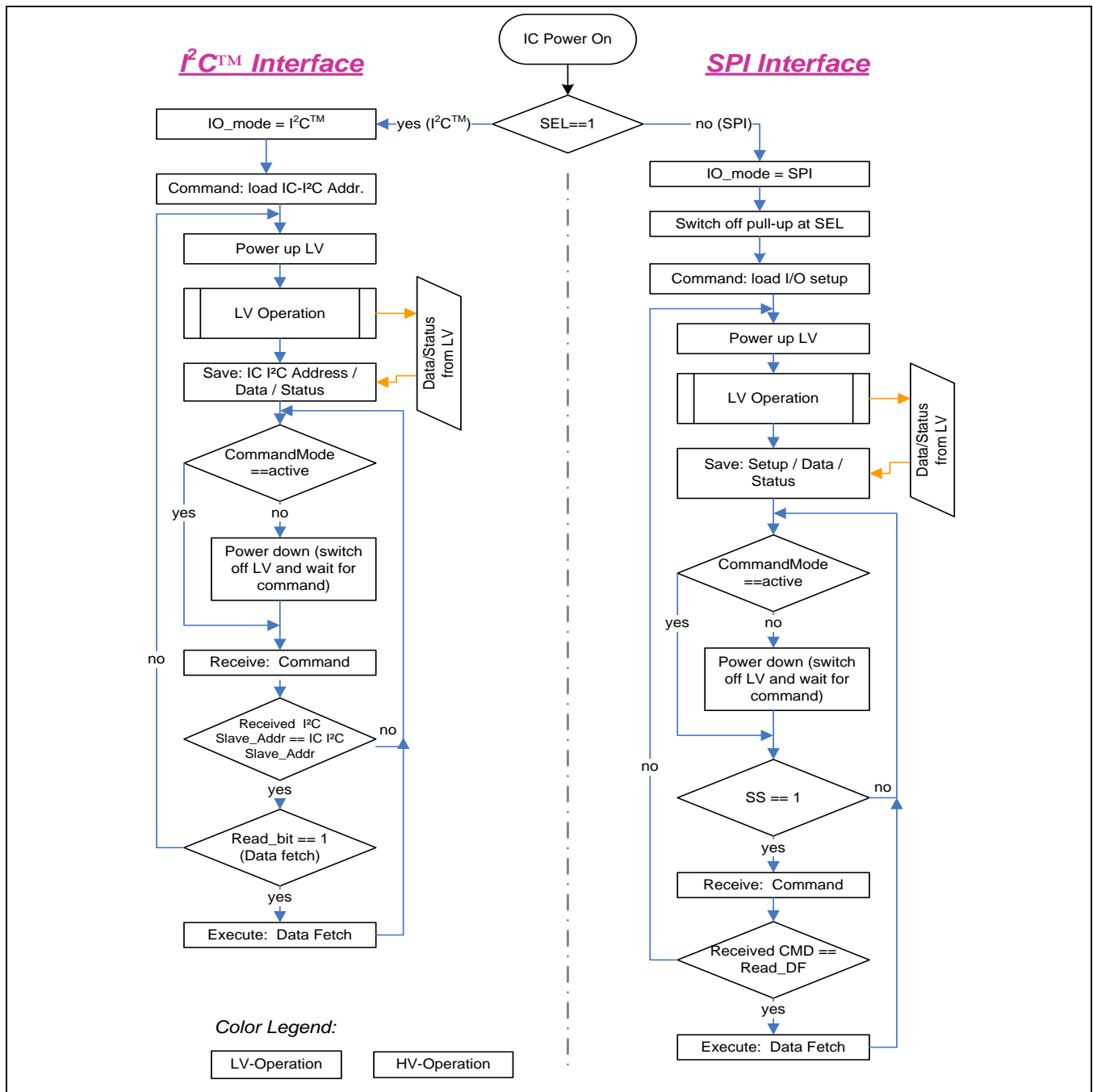
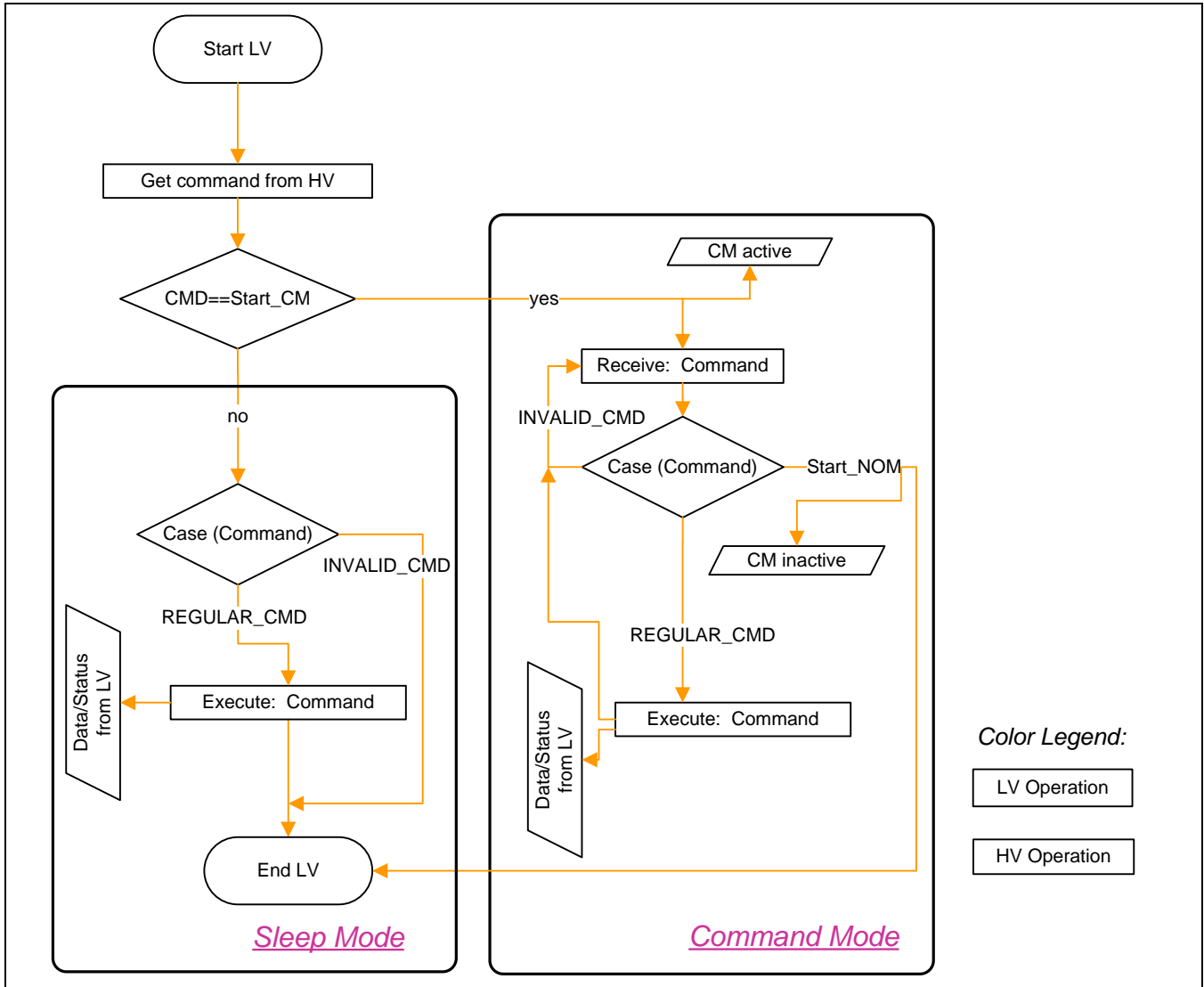

Figure 3.2 Operational Flow Chart: Command Mode and Normal Mode



3.4. Command Interpretation

3.4.1. SPI/I²C™ Commands

The user-accessible section of memory includes addresses 00_{HEX} through 17_{HEX} in the OTP memory that is designated by the user memory page pointer. Because each of the four OTP memory pages cannot be rewritten or erased, the memory page pointer must be incremented to the next OTP memory page in order to write to memory again (see Table 3.1 for the command). After all four user-accessible OTP memory pages have been used, further write operations are not possible and the “Memory Full” bit is returned as set in the status byte after write operations (see section 3.5.1).

The SPI/I²C™ commands supported by the ZSSC3027 are listed in Table 3.1. The command to read an address in the user memory is the same as its address. The command to read the 16-bit memory status of the data at an address in user memory is the address plus 20_{HEX}. The command to write to an address in user memory is the address plus 40_{HEX}.

There is a IDT-reserved section of memory that can be read but not over-written by the user.

Table 3.1 SPI/I²C™ Commands

Note: Every return starts with a status byte followed by the data word as described in section 3.5.1.

Command (Byte)	Return	Description	Normal Mode	Command Mode
00 _{HEX} to 17 _{HEX}	16-bit user data	Read data in the user memory address (00 _{HEX} to 17 _{HEX}) matching the command (might not be using all addresses).	yes	yes
20 _{HEX} to 37 _{HEX}	16-bit user memory status	Read memory status for address specified by command minus 20 _{HEX} (addresses 00 _{HEX} to 17 _{HEX} respectively; see section 3.6.2 for a description of the memory status).	yes	yes
40 _{HEX} to 57 _{HEX} followed by data (0000 _{HEX} to FFFF _{HEX})	—	Write data to user memory at address specified by command minus 40 _{HEX} (addresses 00 _{HEX} to 17 _{HEX} respectively; might not be using all addresses).	no	yes
70 _{HEX} to 7E _{HEX}	16-bit IDT-reserved memory data	Read data in IDT-reserved memory at address specified by command minus 70 _{HEX} (second set of addresses 00 _{HEX} to 0E _{HEX} respectively).	no	yes
80 _{HEX} to 8E _{HEX}	16-bit IDT-reserved memory status	Read memory status bytes for IDT-reserved memory data at address specified by command minus 80 _{HEX} (second set of addresses 00 _{HEX} to 0E _{HEX} respectively; see section 3.6.2 for a description of the memory status bytes).	no	yes
5E _{HEX}	—	Increment user memory page pointer.	no	yes
A0 _{HEX} to A7 _{HEX} followed by XXXX _{HEX} (see Table 3.2)	16-bit wide raw data	Get_Raw This command can be used to perform a measurement and write the raw ADC data into the output register. The LSB of the command determines how the AFE configuration register is loaded for the Get_Raw measurement (see Table 3.2).	yes	yes
A8 _{HEX}	—	Start_NOM Exit Command Mode and transition to Normal Mode.	no	yes
A9 _{HEX}	—	Start_CM Exit Normal Mode and transition to Command Mode.	yes	no

Command (Byte)	Return	Description	Normal Mode	Command Mode
AA _{HEX}	—	Write_ChecksumC If not yet written, the checksum for the valid user MTP page is calculated and written to MTP.	no	yes
AC _{HEX}	16-bit fully corrected bridge measurement data + 16-bit corrected internal temperature	Measure Triggers full measurement cycle (AZBM, BM, AZTM, and TM, as described in section 3.2) and calculation and storage of data in interface (configurations from MTP).	yes	yes
FX _{HEX}	Status followed by last data	NOP Only valid for SPI (see 3.5.1 and 3.5.2).	yes	yes

Table 3.2 Get_Raw Commands

Command	Measurement	AFE Configuration Register
A0 _{HEX} followed by 0000 _{HEX}	BM – Bridge Measurement	<i>BM_Config</i>
A1 _{HEX} followed by ssss _{HEX}	BM – Bridge Measurement	sss is the user's configuration setting for the measurement provided via the interface. The format and purpose of configuration bits must be according to the definitions for <i>BM_Config</i> .
A2 _{HEX} followed by 0000 _{HEX}	BM-AZBM – Auto-Zero Corrected Bridge Measurement ¹⁾	<i>BM_Config</i>
A3 _{HEX} followed by ssss _{HEX}	BM-AZBM – Auto-Zero Corrected Bridge Measurement ²⁾	sss is the user's configuration setting for the measurement provided via the interface. The format and purpose of configuration bits must be according to the definitions for <i>BM_Config</i> .
A4 _{HEX} followed by 0000 _{HEX}	TM – Temperature Measurement	IDT-defined register
A5 _{HEX} followed by ssss _{HEX}	TM – Temperature Measurement	sss is the user's configuration setting for the measurement provided via the interface. The format and purpose of configuration bits must be according to the definitions for <i>BM_Config</i> being valid for temperature measurement in this case (bits [15:13] will be ignored).
A6 _{HEX} followed by 0000 _{HEX}	TM-AZTM – Auto-Zero Corrected Temperature Measurement ¹⁾	IDT-defined register
A7 _{HEX} followed by ssss _{HEX}	TM-AZTM – Auto-Zero Corrected Temperature Measurement ²⁾	sss is the user's configuration setting for the measurement provided via the interface. The format and purpose of configuration bits must be according to the definitions for <i>BM_Config</i> being valid for temperature measurement in this case (bits [15:13] will be ignored).

1) Recommended for raw data collection during calibration coefficient determination using measurement setups pre-programmed in MTP.
2) Recommended for raw data collection during calibration coefficient determination using un-programmed (i.e., not in MTP), external measurement setups; e.g., for evaluation purposes.

3.5. Communication Interface

3.5.1. Common Functionality

Commands are handled by the command interpreter in the low-voltage (LV) section. Commands that need additional data are not treated differently than other commands because the high-voltage (HV) interface is able to buffer the command and all the data that belongs to the command and the command interpreter is activated as soon as a command byte is received.

Every response starts with a status byte followed by the data word. The data word depends on the previous command. It is possible to read the same data more than once if the read request is repeated (I²C™) or a NOP command is sent (SPI). If the next command is not a read request (I²C™) or a NOP (SPI), it invalidates any previous data.

The status byte contains the following bits (see Table 3.3, Table 3.4, and Table 3.5 for sequence):

- Power indication (bit 6): 1 if the device is powered (V_{DDB} on); 0 if not powered. This is needed for SPI Mode where the master reads all zeros if the device is not powered or in power-on reset (POR).
- Busy indication (bit 5): 1 if the device is busy, which indicates that the data for the last command is not available yet. No new commands are processed if the device is busy.
- Actual ZSSC3027 mode (bits 4:3): 00 = Normal Mode; 01 = Command Mode; 1X = IDT-reserved.
- Memory integrity/error flag (bit 2): 0 if integrity test passed, 1 if test failed. This bit indicates whether the checksum-based integrity check passed or failed. Correctable errors are not reported but can be queried with the memory status commands (see section 3.6.2). The memory error status bit is calculated only during the power-up sequence, so a newly written CRC will only be used for memory verification and status update after a subsequent ZSSC3027 power-on reset (POR).
- Data transfer/correction (bit 1): If the last command was a memory write, this bit is 0 if the last memory write was successful (memory not full yet); otherwise it is 1 (e.g., page increase but already on last MTP page). If the last command was a memory read, this bit is 1 if the data was corrected.

Table 3.3 General Status Byte

Bit	7	6	5	4	3	2	1	0
Meaning	0	Powered?	Busy?	Mode		Memory error?	Internal data transfer	Special

Table 3.4 Status Byte for Read Operations

Bit	7	6	5	4	3	2	1	0
Meaning	0	Powered?	Busy?	Mode		Memory error?	Data corrected?	ALU saturation?

Table 3.5 Status Byte for Write Operations

Bit	7	6	5	4	3	2	1	0
Meaning	0	Powered?	Busy?	Mode		Memory error?	Memory full? ⇔ MTP write reject?	Don't care

Table 3.6 Mode Status

Status[4:3]	Mode
00	Normal Mode
01	Command Mode
10	IDT-Reserved
11	Command Mode and Reserved

Further status information is provided by the EOC pin. The EOC pin is set when a measurement and calculation have been completed.

3.5.2. SPI

The SPI Mode is available when the SEL pin = 0. The polarity and phase of the SPI clock are programmable via the CKP_CKE setting in address 02_{HEX} as described in Table 3.8. CKP_CKE is two bits: CPHA (bit 10), which selects which edge of SCLK latches data, and CPOL (bit 11), which indicates whether SCLK is high or low when it is idle. The polarity of the SS signal and pin are programmable via the SS_polarity setting (bit 9). The different combinations of polarity and phase are illustrated in the figures below.

Figure 3.3 SPI Configuration CPHA=0

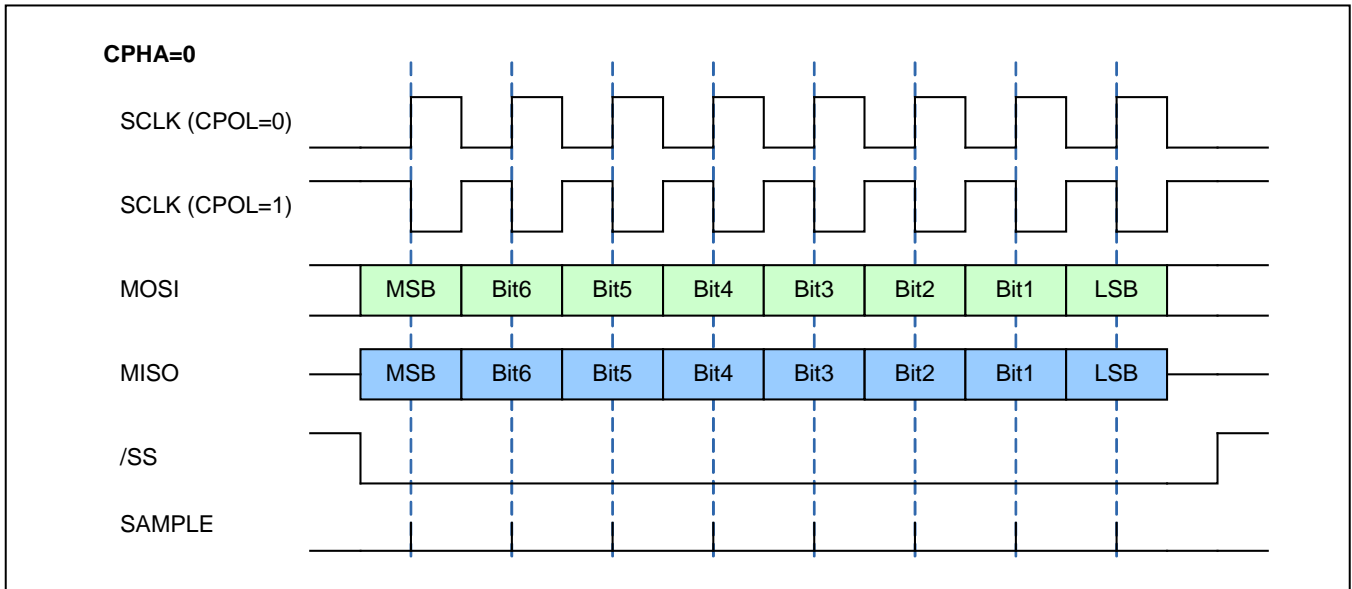
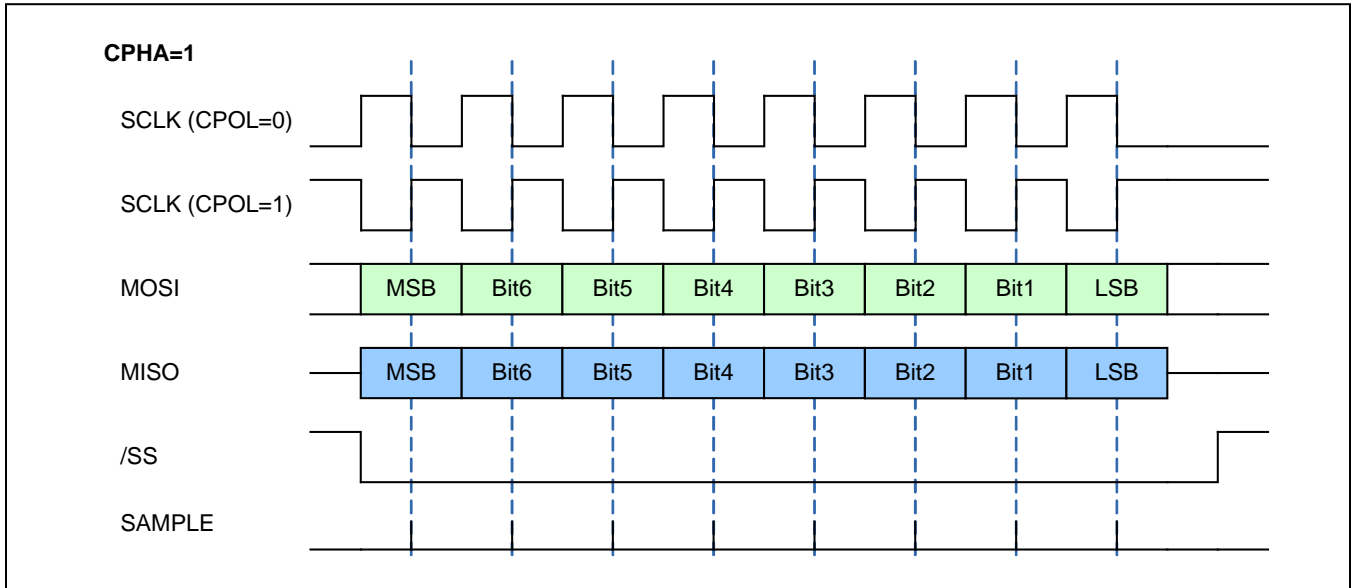

Figure 3.4 SPI Configuration CPHA=1



In SPI mode, each command except NOP is started as shown in Figure 3.5. After the execution of a command (busy = 0), the expected data can be read as illustrated in Figure 3.6 or if no data are returned by the command, the next command can be sent. The status can be read at any time with the NOP command (see Figure 3.7).

Figure 3.5 SPI Command Request

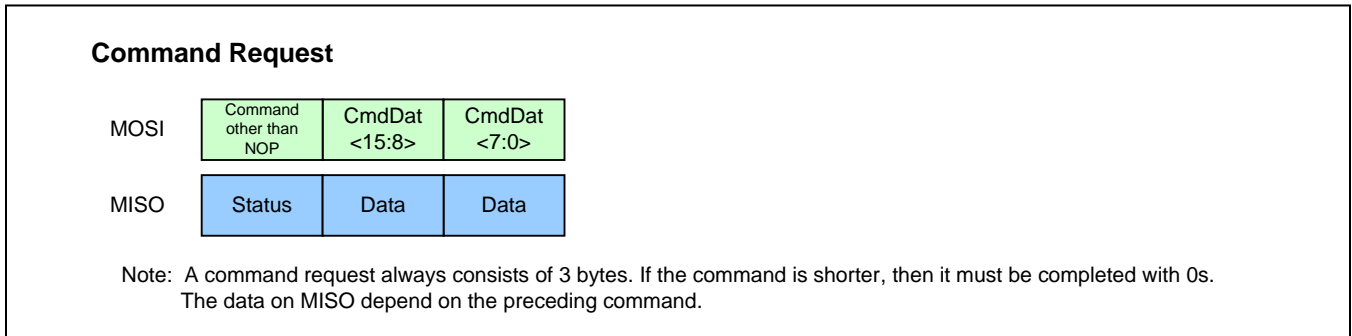
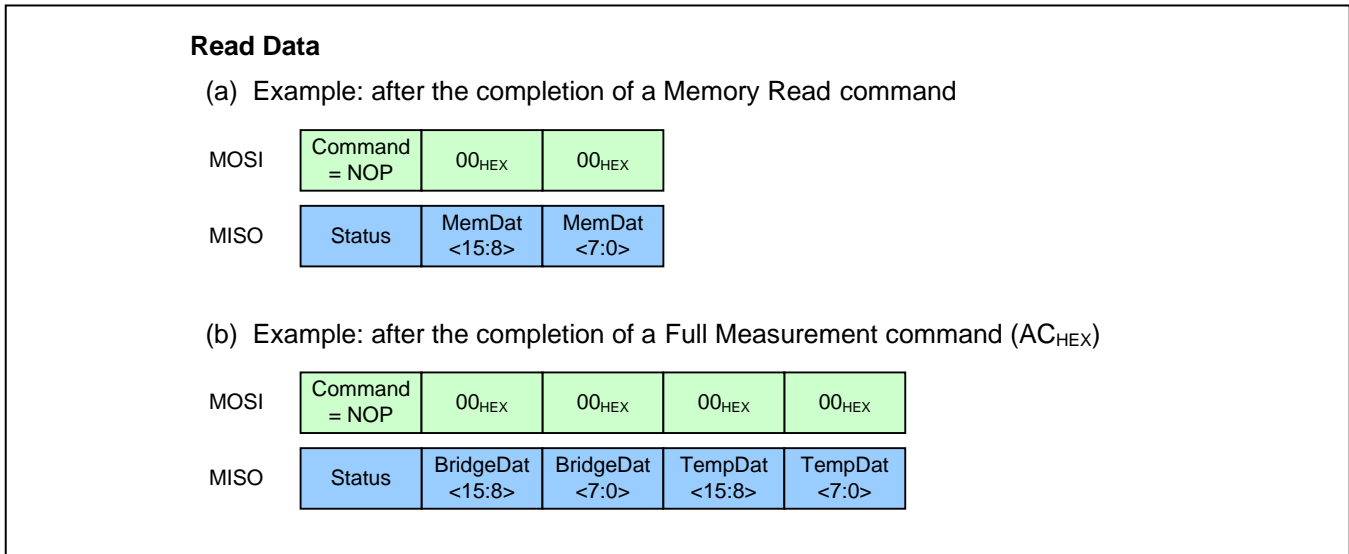

Figure 3.6 SPI Read Status



Figure 3.7 SPI Read Data



3.5.3. I²C™

I²C Mode is selected by the SEL pin = 1. In I²C Mode, each command is started as shown in Figure 3.8. Only the number of bytes that is needed for the command must be sent. An exception is the HS-mode where 3 bytes must always be sent as in SPI Mode. After the execution of a command (busy = 0), the expected data can be read as illustrated in Figure 3.10 or if no data are returned by the command, the next command can be sent. The status can be read at any time as described in Figure 3.9.

Figure 3.8 I²C™ Command Request

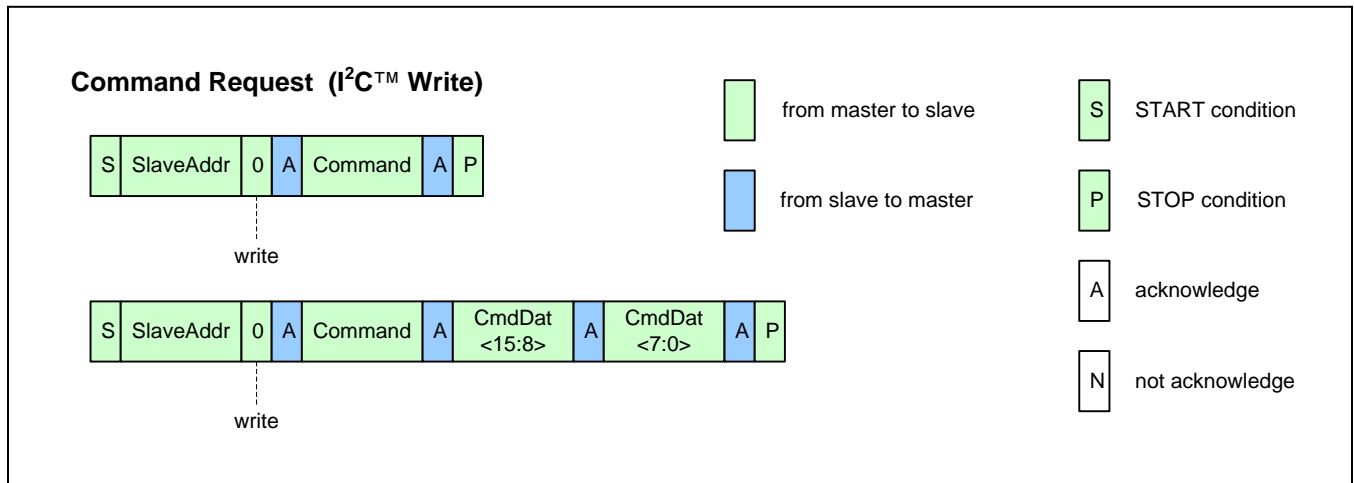

Figure 3.9 I²C™ Read Status

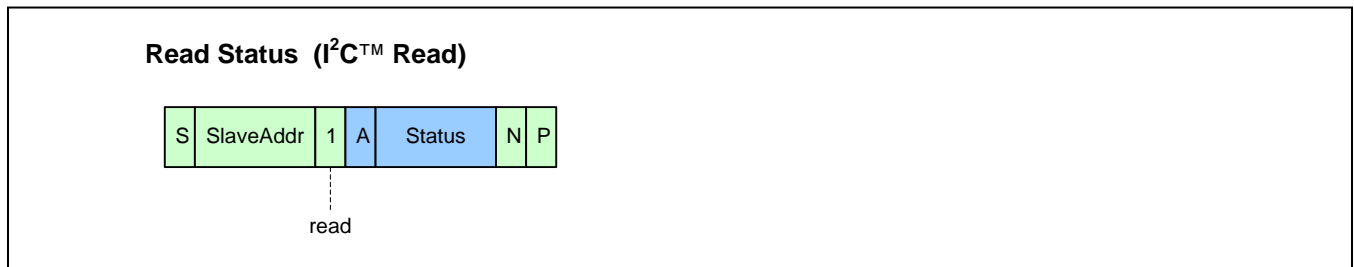
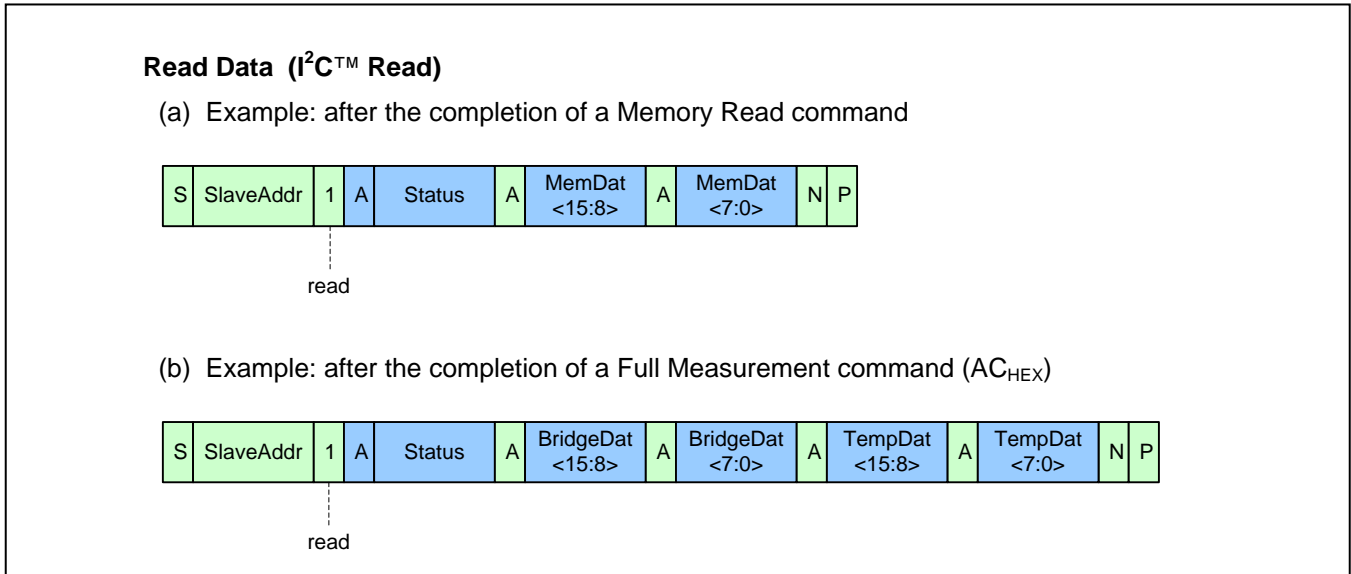

Figure 3.10 I²C™ Read Data



All mandatory I²C-bus protocol features are implemented. Optional features like clock stretching, 10-bit slave address, etc., are not supported by the ZSSC3027's interface.

In I²C-High-Speed Mode, a command consists of a fixed length of three bytes.

3.6. Memory

In the ZSSC3027, the memory is organized page-wise and can be programmed multiple (4) times (MTP). Each register can only be programmed once per page. The valid page is determined by the page counter which can be incremented with the command 5E_{HEX} – this leads to a “reset” of all registers and a re-programming is necessary. Increasing the customer page counter will disable all old register contents of the former page. It is possible to (re-)program a total of 4 pages. Resetting the page counter is not possible. The page counter starts with 0 and can be incremented to a maximum of 3. If the 4th memory page has been used, no further changes in the memory are possible – careful writing and page incrementing is strongly recommended. There are two MTP page types:

- Customer Page: Accessible by means of regular write operations (40_{HEX} to 57_{HEX}). It contains the customer ID, interface setup data, measurement setup information, and calibration coefficients, etc.
- IDT Page: Only accessible for write operations by IDT. The IDT page contains specific trim information and is programmed during manufacturing test by IDT.

3.6.1. Programming Memory

Programming memory requires a specific supply voltage level (>2.9V) at the VDD pin (see section 1.3 for specifications). The MTP programming voltage itself is generated by means of an implemented charge pump, generating an internal memory programming voltage (VPP); no additional, external voltage, other than VDD needed. The program timing is shown in Figure 3.11. Supplying the ZSSC3027 with VDD>2.9V during memory programming is required. After the memory is programmed, it must be read again to verify the validity of the memory contents.

Figure 3.11 Memory Program Operation

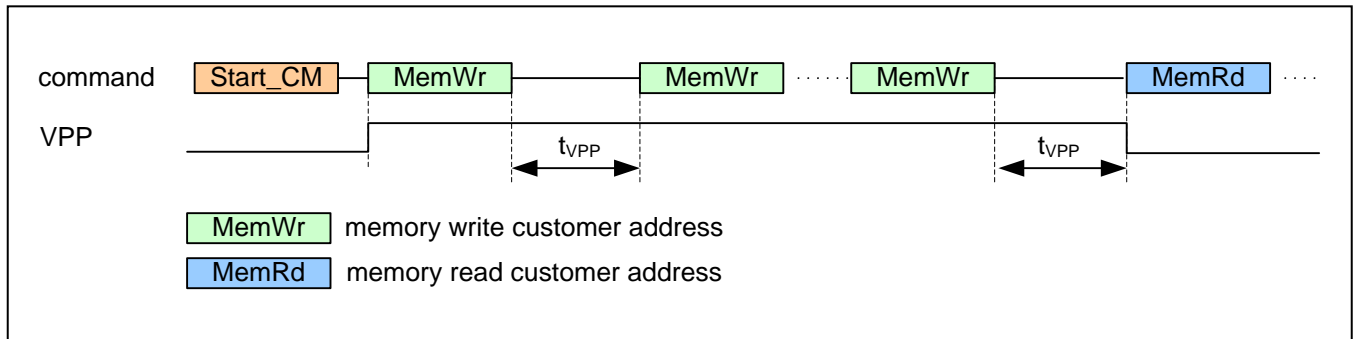

3.6.2. Memory Status Commands

The 16-bit memory status answer for the commands 20_{HEX} to 37_{HEX} and 80_{HEX} to 8E_{HEX} contains the following information:

- One bit indicating if the data read was corrected.
- Two bits indicating the current page in use.

Table 3.7 Memory Status Word

Bit	Description
15 (MSB)	Data was corrected (0: no, 1: yes)
14	Current page
13	
12:0	Undefined – do not use

3.6.3. Memory Contents

Table 3.8 MTP Memory Content Assignments

MTP Address	Word / Bit Range	Default Setting	Description	Notes / Explanations
00 _{HEX}	15:0	0000 _{HEX}	Cust_ID0	Customer ID byte 0 (combines with memory word 01 _{HEX} to form customer ID)
01 _{HEX}	15:0	0000 _{HEX}	Cust_ID1	Customer ID byte 1 (combines with memory word 00 _{HEX} to form customer ID)
Interface Configuration				
02 _{HEX}	6:0	000 0000 _{BIN}	Slave_Addr	I ² C™ slave address; valid range: 00 _{HEX} to 7F _{HEX} (default: 00 _{HEX}) Note: address codes 04 _{HEX} to 07 _{HEX} are reserved for entering the I ² C™ High Speed Mode.
	8:7	00 _{BIN}	-	Reserved
	9	0 _{BIN}	SS_polarity	Determines the polarity of the Slave Select pin (SS) for SPI operation: <ul style="list-style-type: none"> 0 ⇔ Slave Select is active low (SPI and ZSSC3027 are active if SS==0) 1 ⇔ Slave Select is active high (SPI and ZSSC3027 are active if SS==1)
	11:10	00 _{BIN}	CKP_CKE	Clock polarity and clock-edge select—determines polarity and phase of SPI interface clock with the following modes: <ul style="list-style-type: none"> 00 ⇔ SCLK is low in idle state, data latch with rising edge and data output with falling edge 01 ⇔ SCLK is low in idle state, data latch with falling edge and data output with rising edge 10 ⇔ SCLK is high in idle state, data latch with falling edge and data output with rising edge 11 ⇔ SCLK is high in idle state, data latch with rising edge and data output with falling edge
	15:12		-	Not assigned

MTP Address	Word / Bit Range	Default Setting	Description	Notes / Explanations
Signal Conditioning Parameters				
03 _{HEX}	0	0 _{BIN}	Offset_B[16]	Bridge offset, bit[16]—functions as the MSB and combines with Offset_B[15:0] in 05 _{HEX} to form the 17-bit coefficient's absolute value
	1	0 _{BIN}	Offset_B_sign	Sign for sensor bridge offset (Offset_B): 0 => a positive value or 1 => a negative value
	2	0 _{BIN}	Gain_B[16]	Bridge gain, bit[16] —functions as the MSB and combines with Gain_B[15:0] in 06 _{HEX} to form the 17-bit coefficient's absolute value
	3	0 _{BIN}	Gain_B_sign	Sign of the sensor bridge gain (Gain_B): 0 => a positive value or 1 => a negative value
	4	0 _{BIN}	Tcg[16]	1 st -order temperature coefficient of the bridge gain, bit[16] —functions as the MSB and combines with Tcg[15:0] in 07 _{HEX} to form the 17-bit coefficient's absolute value
	5	0 _{BIN}	Tcg_sign	Sign of 1 st -order temperature coefficient (Tcg): 0 => a positive value or 1 => a negative value
	6	0 _{BIN}	Tco[16]	1 st -order temperature coefficient of the bridge offset, bit[16] —functions as the MSB and combines with Tco[15:0] in 08 _{HEX} to form the 17-bit coefficient's absolute value
	7	0 _{BIN}	Tco_sign	Sign of 1 st -order temperature coefficient (Tco): 0 => a positive value or 1 => a negative value
	8	0 _{BIN}	SOT_tco[16]	2 nd -order temperature coefficient of the bridge offset, bit[16] —functions as the MSB and combines with SOT_tco[15:0] in 09 _{HEX} to form the 17-bit coefficient's absolute value
	9	0 _{BIN}	SOT_tco_sign	Separate sign setting for 2 nd -order temperature coefficient (SOT_tco): 0 => a positive value or 1 => a negative value
	10	0 _{BIN}	SOT_tcg[16]	2 nd -order temperature coefficient of the bridge gain, bit[16] —functions as the MSB and combines with SOT_tcg[15:0] in 0A _{HEX} to form the 17-bit coefficient's absolute value
	11	0 _{BIN}	SOT_tcg_sign	Separate sign setting for 2 nd -order temperature coefficient (SOT_tcg): 0 => a positive value or 1 => a negative value

MTP Address	Word / Bit Range	Default Setting	Description	Notes / Explanations
	12	0 _{BIN}	SOT_bridge[16]	2 nd -order coefficient of the bridge signal, bit[16] — functions as the MSB and combines with SOT_bridge[15:0] in 0B _{HEX} to form the 17-bit coefficient's absolute value
	13	0 _{BIN}	SOT_bridge_sign	Separate sign setting for 2 nd -order bridge coefficient (SOT_bridge): 0 => a positive value or 1 => a negative value
	14	0 _{BIN}	SOT_curve	Type of second-order curve correction for the bridge sensor signal. 0 ⇔ parabolic curve 1 ⇔ s-shaped curve
	15	0 _{BIN}	TSETL_sign	Separate sign setting for T_SETL: 0 => a positive value or 1 => a negative value
04 _{HEX}	0	0 _{BIN}	Gain_T[16]	Temperature gain of temperature sensor, bit[16] — functions as the MSB and combines with Gain_T[15:0] in 0D _{HEX} to form the 17-bit coefficient's absolute value
	1	0 _{BIN}	Gain_T_sign	Separate sign setting for the temperature gain (Gain_T): 0 => a positive value or 1 => a negative value
	2	0 _{BIN}	SOT_T[16]	2 nd -order temperature coefficient of temperature sensor, bit[16] — functions as the MSB and combines with SOT_T[15:0] in 0E _{HEX} to form the 17-bit coefficient's absolute value
	3	0 _{BIN}	SOT_T_sign	Separate sign setting for 2 nd -order temperature coefficient (SOT_T): 0 => a positive value or 1 => a negative value
	4	0 _{BIN}	Offset_T[16]	Temperature offset of temperature sensor, bit[16] — functions as the MSB and combines with Offset_T[15:0] in 0C _{HEX} to form the 17-bit coefficient's absolute value
	5	0 _{BIN}	Offset_T_sign	Separate sign setting for the temperature offset (Offset_T): 0 => a positive value or 1 => a negative value
	15:6	0000000000 _{BIN}	-	Not assigned

MTP Address	Word / Bit Range	Default Setting	Description	Notes / Explanations
05 _{HEX}	15:0	0000 _{HEX}	Offset_B[15:0]	<p>Bits [15:0] of the bridge offset correction coefficient, which is an 18-bit wide absolute value (the respective MSBs Offset_B[16] and sign, Offset_B_sign, are under bits[1:0] in 03_{HEX})</p> <p>Valid settings:</p> <ul style="list-style-type: none"> [-1/16 to 15/16] = 7000_{HEX} [-2/16 to 14/16] = 6000_{HEX} [-3/16 to 13/16] = 5000_{HEX} [-4/16 to 12/16] = 4000_{HEX} [-5/16 to 11/16] = 3000_{HEX} [-6/16 to 10/16] = 2000_{HEX} [-7/16 to 9/16] = 1000_{HEX} [-8/16 to 8/16] = 0000_{HEX}
06 _{HEX}	15:0	0000 _{HEX}	Gain_B[15:0]	Bits[15:0] of 17-bit wide absolute value of the bridge gain coefficient (the respective MSBs, Gain_B[16] and sign, Gain_B_sign, are under bits[3:2] in 03 _{HEX})
07 _{HEX}	15:0	0000 _{HEX}	Tcg[15:0]	Coefficient for temperature correction of the bridge gain term (the respective MSBs, Tcg[16] and sign, Tcg_sign, are under bits[5:4] in 03 _{HEX})
08 _{HEX}	15:0	0000 _{HEX}	Tco[15:0]	Coefficient for temperature correction of the bridge offset term (the respective MSBs, Tco[16] and sign, Tco_sign, are under bits[7:6] in 03 _{HEX})
09 _{HEX}	15:0	0000 _{HEX}	SOT_tco[15:0]	2 nd order term applied to Tco (the respective MSBs, SOT_tco[16] and sign, SOT_tco_sign, are under bits[9:8] in 03 _{HEX})
0A _{HEX}	15:0	0000 _{HEX}	SOT_tcg[15:0]	2 nd order term applied to Tcg (the respective MSBs, SOT_tcg[16] and sign, SOT_tcg_sign, are under bits[11:10] in 03 _{HEX})
0B _{HEX}	15:0	0000 _{HEX}	SOT_bridge[15:0]	2 nd order term applied to the sensor bridge readout (the respective MSBs, SOT_bridge[16] and sign, SOT_bridge_sign are under bits[13:12] in 03 _{HEX})
0C _{HEX}	15:0	0000 _{HEX}	Offset_T[15:0]	<p>Bits [15:0] of the temperature offset correction coefficient (the respective MSBs, Offset_T[16] and sign, Offset_T_sign, are under bits[5:4] in 04_{HEX})</p> <p>Valid settings:</p> <ul style="list-style-type: none"> [-1/16 to 15/16] = 7000_{HEX} [-2/16 to 14/16] = 6000_{HEX} [-3/16 to 13/16] = 5000_{HEX} [-4/16 to 12/16] = 4000_{HEX} [-5/16 to 11/16] = 3000_{HEX} [-6/16 to 10/16] = 2000_{HEX} [-7/16 to 9/16] = 1000_{HEX} [-8/16 to 8/16] = 0000_{HEX}

MTP Address	Word / Bit Range	Default Setting	Description	Notes / Explanations
0D _{HEX}	15:0	0000 _{HEX}	Gain_T[15:0]	Bits [15:0] of the absolute value of the temperature gain coefficient (the respective MSBs, Gain_T[16] and sign, Gain_T_sign, are under bits[1:0] in 04 _{HEX})
0E _{HEX}	15:0	0000 _{HEX}	SOT_T[15:0]	2 nd order term applied to the temperature reading (the respective MSBs, SOT_T[16] and sign, SOT_T_sign, are under bits[3:2] in 04 _{HEX})
0F _{HEX}	15:0	0000 _{HEX}	T_SETL	Stores raw temperature reading at the temperature at which low calibration points were taken
Measurement Configuration Register (BM_config)				
10 _{HEX}	1:0	00 _{BIN}	Gain_stage1	Gain setting for the 1 st PREAMP stage with Gain_stage1: <ul style="list-style-type: none"> • 00 ⇔ 12 • 01 ⇔ 20 • 10 ⇔ 30 • 11 ⇔ 40
	4:2	000 _{BIN}	Gain_stage2	Gain setting for the 2 nd PREAMP stage with Gain_stage2: <ul style="list-style-type: none"> • 000 ⇔ 1.1 • 001 ⇔ 1.2 • 010 ⇔ 1.3 • 011 ⇔ 1.4 • 100 ⇔ 1.5 • 101 ⇔ 1.6 • 110 ⇔ 1.7 • 111 ⇔ 1.8
	5	0 _{BIN}	Gain_polarity	Set up the polarity of the sensor bridge's gain (inverting of the chopper) with <ul style="list-style-type: none"> • 0 ⇔ positive (no polarity change) • 1 ⇔ negative (180° polarity change)
	7:6	00 _{BIN} (11 _{BIN})	Msb	Absolute number of bits for the MSB conversion in the ADC with Msb: <ul style="list-style-type: none"> • 00 ⇔ 10-bit • 01 ⇔ 12-bit • 10 ⇔ 14-bit • 11 ⇔ 16-bit

MTP Address	Word / Bit Range	Default Setting	Description	Notes / Explanations
	9:8	00 _{BIN}	Lsb	Absolute number of bits for the LSB conversion in the ADC with Lsb: <ul style="list-style-type: none"> • 00 ⇔ 0-bit (single-stage ADC) • 01 ⇔ 2-bit • 10 ⇔ 4-bit • 11 ⇔ 6-bit
	12:10	000 _{BIN}	A2D_Offset	ADC offset and resulting A2D input range [Vref] with A2D_Offset: <ul style="list-style-type: none"> • 000 ⇔ 1/16 results in range [-1/16, 15/16] • 001 ⇔ 2/16 results in range [-2/16, 14/16] • 010 ⇔ 3/16 results in range [-3/16, 13/16] • 011 ⇔ 4/16 results in range [-4/16, 12/16] • 100 ⇔ 5/16 results in range [-5/16, 11/16] • 101 ⇔ 6/16 results in range [-6/16, 10/16] • 110 ⇔ 7/16 results in range [-7/16, 9/16] • 111 ⇔ 8/16 results in range [-8/16, 8/16]
	14:13	00 _{BIN}	Temp_ADC	Selection between fixed ADC segmentations for temperature measurements: <ul style="list-style-type: none"> • 00 ⇔ setup according to IDT-reserved memory (recommended setup for best performance and speed trade-off) • 01 ⇔ MSB=16, LSB=0 (16-bit) • 10 ⇔ MSB=10, LSB=6 (16-bit) • 11 ⇔ MSB=12, LSB=4 (16-bit)
	15	0 _{BIN}	-	Reserved
Customer Registers				
11 _{HEX}				Arbitrary customer use
12 _{HEX}				Arbitrary customer use
13 _{HEX}				Arbitrary customer use
14 _{HEX}				Arbitrary customer use
15 _{HEX}				Arbitrary customer use
16 _{HEX}				Arbitrary customer use
17 _{HEX}	15:0	-	ChecksumC	Generated (checksum) for user page through a linear feedback shift register (LFSR); signature is checked with power-up to ensure memory content integrity

The memory integrity checksum (referred to as *CRC*) is generated through a linear feedback shift register with the polynomial:

$$g(x) = x^{16} + x^{15} + x^2 + 1 \quad \text{with the initialization value: FFFF}_{\text{HEX}}.$$

3.7. Calibration Sequence

Calibration essentially involves collecting raw signal and temperature data from the sensor-IC system for different known bridge values and temperatures. This raw data can then be processed by the calibration master (assumed to be a PC), and the calculated calibration coefficients can then be written to MTP memory. Below is a brief overview of the steps involved in calibrating the ZSSC3027.

There are three main steps to calibration:

1. *Assigning a unique identification to the ZSSC3027.* This identification is written to shadow RAM and later programmed in MTP memory. This unique identification can be stored in the two 16-bit registers dedicated to customer ID. It can be used as an index into a database stored on the calibration PC. This database will contain all the raw values of bridge readings and temperature readings for that part, as well as the known bridge measurand conditions and temperature to which the bridge was exposed.
2. *Data collection.* Data collection involves getting uncorrected or raw data from the bridge at different known measurand values and temperatures. Then this data is stored on the calibration PC using the unique identification of the device as the index to the database.
3. *Coefficient calculation and storage in MTP memory.* After enough data points have been collected to calculate all the desired coefficients, the coefficients can be calculated by the calibrating PC and written to the shadow RAM. After that, MTP memory is programmed with the contents of the shadow RAM.
4. *Result.* The sensor signal and the characteristic temperature effect on output will be linearized according to the setup-dependent maximum output range.

It is essential to perform the calibration with a fixed programming setup during the data collection phase. In order to prevent any accidental misprocessing, it is further recommended to keep the MTP memory setup stable during the whole calibration process as well as in the subsequent operation. A ZSSC3027 calibration only fits the single setup used during its calibration. Changes of functional parameters after a successful calibration can decrease the precision and accuracy performance of the ZSSC3027 as well as of the whole application.

3.7.1. Calibration Step 1 – Assigning Unique Identification

Assign a unique identification number to the ZSSC3027 by using the memory write command (40_{HEX} followed by two bytes of identification data and 41_{HEX} followed by two bytes of identification data; see Table 3.1 and Table 3.8) to write the identification number to Cust_ID0 at memory address 00_{HEX} and Cust_ID1 at address 01_{HEX} as described in section 3.6.1. These two 16-bit registers allow for more than 4 trillion unique devices.

3.7.2. Calibration Step 2 – Data Collection

The number of unique points (measurand and/or temperature) at which calibration must be performed generally depends on the requirements of the application and the behavior of the resistive bridge in use. The minimum number of points required is equal to the number of bridge coefficients to be corrected with a minimum of three different temperatures at three different bridge values. For a full calibration resulting in values for all 7 possible bridge coefficients and 3 possible temperature coefficients, a minimum of 7 pairs of bridge with temperature measurements must be collected.

Within this minimum 3x3 measurements field, data must be collected for the specific value pairs (at known conditions) and then processed to calculate the coefficients. In order to obtain the potentially best and most robust coefficients, it is recommended that measurement pairs (temperature vs. measurand) be collected at the outer corners of the intended operation range or at least at points that are located far from each other. It is also essential to provide highly precise reference values as nominal, expected values.

Note: The measurement precision of the external calibration-measurement equipment should be ten times more accurate than the expected ZSSC3027 output precision after calibration in order to avoid precision losses caused by the nominal reference values (e.g., measurand signal and temperature deviations).

Note: An appropriate selection of measurement pairs can significantly improve the overall system performance.

The determination of the measurand-related coefficients will use all of the measurement pairs. For the temperature-related correction coefficients, three of the measurement pairs (at three different temperatures) will be used.

Note: There is an inherent redundancy in the 7 bridge-related and 3 temperature-related coefficients. Since the temperature is a necessary output (which also needs correction), the temperature-related information is mathematically separated, which supports faster and more efficient DSP calculations during the normal usage of the sensor-IC system.

The recommended approach for data collection is to make use of the raw-measurement commands:

- For bridge sensor values:
 - $A2_{\text{HEX}} + 0000_{\text{HEX}}$: Single bridge measurement for which the configuration register will be loaded from the *BM_Config* register (10_{HEX} in MTP); preprogramming the measurement setup in the MTP is required.
 - $A3_{\text{HEX}} + \text{ssss}_{\text{HEX}}$: Single bridge *measurement* for which the *BM_Config* configuration register (Gain, ADC, Offset, etc.) will be loaded as ssss_{HEX} , which is sent as the data following the $A3_{\text{HEX}}$ command.
- For temperature values (grey text indicates values that are possible but will overwrite IDT settings):
 - $A6_{\text{HEX}} + 0000_{\text{HEX}}$: Single temperature measurement for which the configuration register will be loaded from an internal temperature configuration register (preprogrammed by IDT in MTP); preprogramming of the respective configuration is done by IDT prior to IC delivery. This is the recommended approach for temperature data collection.
 - $A7_{\text{HEX}} + \text{ssss}_{\text{HEX}}$: Single temperature measurement for which the configuration register (Gain, ADC, Offset, etc.) will be loaded as ssss_{HEX} and must be provided externally via the interface. The data composition of the temperature configuration register is similar to the *BM_config* (address 10_{HEX}) register for the bridge sensor.

3.7.3. Calibration Step 3 – Coefficient Calculations

The math to perform the coefficient calculation is complicated and will not be discussed in detail. There is a brief overview in the next section. IDT will provide software (DLLs) to perform the coefficient calculation (external to the sensor-IC system) based on auto-zero corrected values. After the coefficients are calculated, the final step is to write them to the MTP memory of the ZSSC3027.

3.8. The Calibration Math

3.8.1. Bridge Signal Compensation

The saturation check in the ZSSC3027 is enhanced compared with older SSCs from IDT. Even saturation effects of the internal calculation steps are detected, allowing the final correction output to still be determined. It is possible to get potentially useful signal conditioning results even if there has been an intermediate saturation during the calculations – these cases are detectable by observing the status bit[0] for each measurement result. Details about the saturation limits and the valid ranges for values are provided in the following equations.

SOT_curve selects whether second-order equations compensate for sensor nonlinearity with a parabolic or S-shaped curve. The parabolic compensation is recommended.

The correction formula for the differential signal reading is represented as a two-step process depending on the *SOT_curve* setting.

Equations for the parabolic *SOT_curve* setting (*SOT_curve* = 0):

Simplified equations:

$$\Delta T = T_Raw - T_{SETL} \quad (1)$$

$$K_1 = 2^{15} + \frac{\Delta T}{2^{15}} \cdot \left(\frac{SOT_tcg}{2^{15}} \cdot \Delta T + Tcg \right) \quad (2)$$

$$K_2 = Offset_B + BR_Raw + \frac{\Delta T}{2^{15}} \cdot \left(\frac{SOT_tco}{2^{15}} \cdot \Delta T + Tco \right) \quad (3)$$

$$Z_{BP} = \frac{Gain_B}{2^{15}} \cdot \frac{K_1}{2^{15}} \cdot K_2 + 2^{15} \quad (\text{delimited to positive number range}) \quad (4)$$

$$B = \frac{Z_{BP}}{2^{15}} \cdot \left(\frac{SOT_bridge}{2^{15}} \cdot Z_{BP} + 2^{15} \right) \quad (\text{delimited to positive number range}) \quad (5)$$

Where

<i>B</i>	=	Corrected bridge reading output via I ² C™ or SPI; range [0 _{HEX} to FFFF _{HEX}]
<i>BR_Raw</i>	=	Raw bridge reading from ADC after AZ correction; range [-1FFFF _{HEX} to 1FFFF _{HEX}]
<i>Gain_B</i>	=	Bridge gain term; range [-1FFFF _{HEX} to 1FFFF _{HEX}]
<i>Offset_B</i>	=	Bridge offset term; range [-1FFFF _{HEX} to 1FFFF _{HEX}]
<i>Tcg</i>	=	Temperature coefficient gain term; range [-1FFFF _{HEX} to 1FFFF _{HEX}]
<i>Tco</i>	=	Temperature coefficient offset term; range [-1FFFF _{HEX} to 1FFFF _{HEX}]
<i>T_Raw</i>	=	Raw temperature reading after AZ correction; range [-1FFFF _{HEX} to 1FFFF _{HEX}]
<i>T_SETL</i>	=	T_Raw reading at which low calibration was performed (e.g., 25°C); range [-FFFF _{HEX} to FFFF _{HEX}]

- SOT_tcg = Second-order term for Tcg non-linearity; range [-1FFFF_{HEX} to 1FFFF_{HEX}]
 SOT_tco = Second-order term for Tco non-linearity; range [-1FFFF_{HEX} to 1FFFF_{HEX}]
 SOT_bridge = Second-order term for bridge non-linearity; range [-1FFFF_{HEX} to 1FFFF_{HEX}]
 Z_{BP} = Intermediary term

Complete equations:

$$\Delta T = \left[T_Raw - T_{SETL} \right]_{-2^{17}}^{2^{17}-1} \quad (6)$$

$$K_1 = \left[2^{15} + \left[\frac{\Delta T}{2^{15}} \cdot \left[\left[\frac{SOT_tcg}{2^{15}} \cdot \Delta T \right]_{-2^{17}}^{2^{17}-1} + Tcg \right]_{-2^{17}}^{2^{17}-1} \right]_{-2^{17}}^{2^{17}-1} \right]_{-2^{17}}^{2^{17}-1} \quad (7)$$

$$K_2 = \left[Offset_B + \left[BR_Raw + \left[\frac{\Delta T}{2^{15}} \cdot \left[\left[\frac{SOT_tco}{2^{15}} \cdot \Delta T \right]_{-2^{17}}^{2^{17}-1} + Tco \right]_{-2^{17}}^{2^{17}-1} \right]_{-2^{17}}^{2^{17}-1} \right]_{-2^{17}}^{2^{17}-1} \right]_{-2^{17}}^{2^{17}-1} \quad (8)$$

$$Z_{BP} = \left[\left[\frac{Gain_B}{2^{15}} \cdot \left[\left[\frac{K_1}{2^{15}} \cdot K_2 \right]_{-2^{17}}^{2^{17}-1} + 2^{15} \right]_{-2^{17}}^{2^{17}-1} \right]_{-2^{17}}^{2^{17}-1} \right]_{-2^{17}}^{2^{17}-1} \quad (9)$$

$$B = \left[\frac{Z_{BP}}{2^{15}} \cdot \left[\left[\frac{SOT_bridge}{2^{15}} \cdot Z_{BP} \right]_{-2^{17}}^{2^{17}-1} + 2^{15} \right]_{-2^{17}}^{2^{17}-1} \right]_{-2^{17}}^{2^{16}-1} \quad (10)$$

Where

$|\dots|$ = absolute value

$[\dots]_{ll}^{ul}$ = bound/saturation number range from ll to ul ; over/under-flow is reported as saturation in status byte

Equations for the S-shaped SOT_curve setting (SOT_curve = 1):

Simplified equations:

$$Z_{BS} = \frac{Gain_B}{2^{15}} \cdot \frac{K_1}{2^{15}} \cdot K_2 \quad (11)$$

$$B = \frac{Z_{BS}}{2^{15}} \cdot \left(\frac{SOT_bridge}{2^{15}} \cdot |Z_{BS}| + 2^{15} \right) + 2^{15} \quad (\text{delimited to positive number range}) \quad (12)$$

Complete equations:

$$Z_{BS} = \left[\frac{Gain_B}{2^{15}} \cdot \left[\frac{K_1}{2^{15}} \cdot K_2 \right]_{-2^{17}}^{2^{17}-1} \right]_{-2^{17}}^{2^{17}-1} \quad (13)$$

$$B = \left[\left[\frac{Z_{BS}}{2^{15}} \cdot \left[\frac{SOT_bridge}{2^{15}} \cdot |Z_{BS}| \right]_{-2^{17}}^{2^{17}-1} + 2^{15} \right]_{-2^{17}}^{2^{17}-1} \right]_{-2^{17}}^{2^{17}-1} + 2^{15} \quad (14)$$

3.8.2. Temperature Signal Compensation

Temperature is measured internally. Temperature correction contains both linear gain and offset terms as well as a second-order term to correct for any nonlinearities. For temperature, second-order compensation for non-linearity is always parabolic. Again, the correction formula is best represented as a two-step process as follows:

Simplified equations:

$$Z_T = \frac{Gain_T}{2^{15}} \cdot (T_Raw + Offset_T) + 2^{15} \quad (\text{delimited to positive number range}) \quad (15)$$

$$T = \frac{Z_T}{2^{15}} \cdot \left(\frac{SOT_T}{2^{15}} \cdot Z_T + 2^{15} \right) \quad (\text{delimited to positive number range}) \quad (16)$$

Complete equations:

$$Z_T = \left[\left[\frac{Gain_T}{2^{15}} \cdot [T_Raw + Offset_T]_{-2^{17}}^{2^{17}-1} \right]_{-2^{17}}^{2^{17}-1} + 2^{15} \right]_0^{2^{17}-1} \quad (17)$$

$$T = \left[\frac{Z_T}{2^{15}} \cdot \left[\left[\frac{SOT_T}{2^{15}} \cdot Z_T \right]_{-2^{17}}^{2^{17}-1} + 2^{15} \right]_{-2^{17}}^{2^{16}-1} \right]_0^{2^{16}-1} \quad (18)$$

Where

- $Gain_T$ = Gain coefficient for temperature; range [-1FFFF_{HEX} to 1FFFF_{HEX}]
- T_Raw = Raw temperature reading after AZ correction; range [-1FFFF_{HEX} to 1FFFF_{HEX}]
- $Offset_T$ = Offset coefficient for temperature; range [-1FFFF_{HEX} to 1FFFF_{HEX}]
- SOT_T = Second-order term for temperature source non-linearity; range [-1FFFF_{HEX} to 1FFFF_{HEX}]
- $[...]_{ll}^{ul}$ = bound/saturation number range from *ll* to *ul*; over/under-flow is reported as saturation in status byte

4 Die Pad Assignments

The ZSSC3027 is available in die form. See Figure 4.1 for pad assignments.

Note that the ZMDI-test pads are for IDT use only.

Figure 4.1 ZSSC3027 Pad Assignments

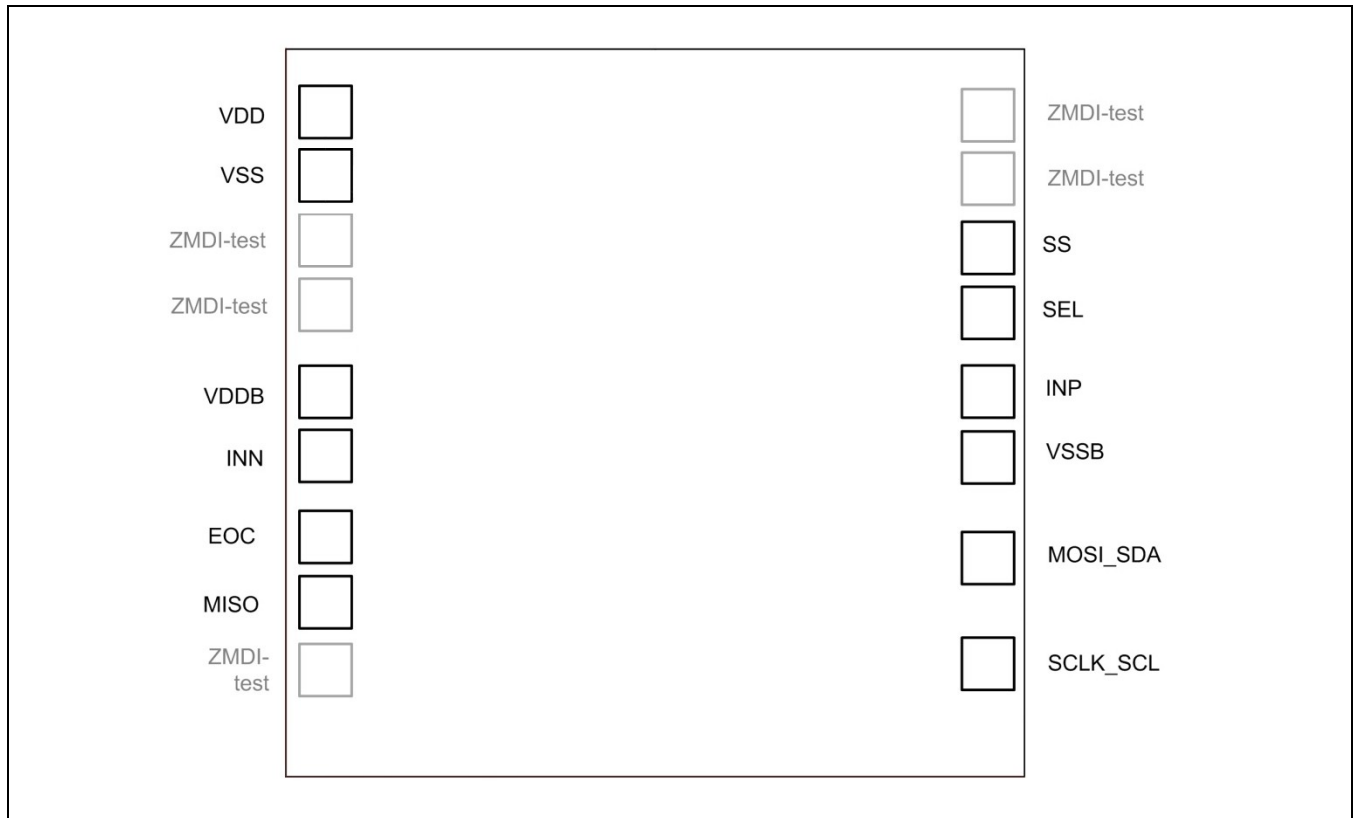

Table 4.1 Pad Assignments

Name	Direction	Type	Description
VDD	IN	Supply	IC positive supply voltage for the ZSSC3027; regular bond pad
VSS	IN	Supply	Ground reference voltage signal
VDDDB	OUT	Analog	Positive bridge supply
INN	IN	Analog	Negative bridge signal
EOC	OUT	Digital	End of conversion; regular bond pad

Name	Direction	Type	Description
MISO	OUT	Digital	Data output for SPI
SCLK/SCL	IN	Digital	Clock input for I ² C™/SPI
MOSI/SDA	IN/Out	Digital	Data input for SPI; data in/out for I ² C™
VSSB	OUT	Analog	Negative bridge supply (bridge sensor ground)
INP	IN	Analog	Positive bridge signal
SEL	IN	Digital	I ² C™ or SPI interface select
SS	IN	Digital	Slave select for SPI
ZMDI-test	-	-	Do not connect to these pads

5 Quality and Reliability

The ZSSC3027 is available in a standard qualification version. For the standard version ZSSC3027CQxxx, all data specified parameters are guaranteed if not stated otherwise.

6 Ordering Sales Codes

Sales Code	Description	Package
ZSSC3027AC1B	Die—temperature range: -40°C to +85 °C	Wafer (304µm) unsawn, tested
ZSSC3027AC6B	Die—temperature range: -40°C to +85 °C	Wafer (725µm) unsawn, tested
ZSSC3027AC7B	Die—temperature range: -40°C to +85°C	Wafer (200µm) unsawn, tested
ZSSC3026-KIT	Evaluation Kit for ZSSC3026, including boards, cable, software, and 1 ZSSC3026 PQFN24 sample. The ZSSC3026 is equivalent to the ZSSC3027. IDT recommends using the ZSSC3026 Evaluation Kit to evaluate the capabilities of the ZSSC3027 because the ZSSC3027 is only available as die.	

Contact IDT Sales for additional information.

7 Related Documents

Document
ZSSC3027 Feature Sheet
ZSSC30x6 Evaluation Kit Documentation*
ZSSC30x6 Application Note—Calibration Sequence and DLL**
<p>* This document is applicable to both the ZSSC30x6 and ZSSC3027 and is included with the software for the ZSSC3026 Evaluation Kit. The software can be freely downloaded from the ZSSC3026 product page.</p> <p>** This document is applicable to both the ZSSC30x6 ICs and the ZSSC3027, and it is available on the ZSSC3026 product page at www.IDT.com/ZSSC3026. A free customer login is required to access this document.</p>

Visit the ZSSC3027 product page at www.IDT.com/ZSSC3027 or contact your nearest sales office for ordering information or the latest version of this document.

8 Glossary

Term	Description
A2D	Analog-to-digital
ACK	Acknowledge (interface's protocol indicator for successful data/command transfer)
ADC	Analog-to-digital converter or conversion
AZ	Auto-zero (unspecific)
AZB	Auto-zero measurement for sensor bridge path
AZT	Auto-zero measurement for temperature path
CLK	Clock
DAC	Digital-to-analog conversion or converter
DF	Data fetch (this is a command type)
DSP	Digital signal processor (digital configuration, calibration, calculation, communication unit)
FSO	Full-scale output (value in percent relative to the ADC maximum output code; resolution dependent)
LSB	Least significant bit ("fine" portion of the converted signal)
LFSR	Linear Feedback Shift Register
MR	Measurement Request (this is a command type)
MSB	Most significant bit ("coarse" portion of the converted signal)
NACK	Not Acknowledge (interface's protocol indicator for unsuccessful data/command transfer)
POR	Power-on reset
PreAmp	Preamplifier

Term	Description
SM	Signal measurement
SOT	Second-order term
TC	Temperature coefficient (of a resistor or the equivalent bridge resistance)
TM	Temperature measurement

9 Document Revision History

Revision	Date	Description
1.00	December 10, 2013	First release of data sheet.
1.01	August 24, 2014	Update for contact information. Minor edit for die description.
	April 20, 2016	Changed to IDT branding