

**Important Notes**

**Disclaimer**

Integrated Device Technology, Inc. and its affiliated companies (herein referred to as "IDT") shall not be liable for any damages arising out of defects resulting from

- (i) delivered hardware or software
- (ii) non-observance of instructions contained in this manual and in any other documentation provided to user, or
- (iii) misuse, abuse, use under abnormal conditions, or alteration by anyone other than IDT.

TO THE EXTENT PERMITTED BY LAW, IDT HEREBY EXPRESSLY DISCLAIMS AND USER EXPRESSLY WAIVES ANY AND ALL WARRANTIES, WHETHER EXPRESS, IMPLIED, OR STATUTORY, INCLUDING, WITHOUT LIMITATION, IMPLIED WARRANTIES OF MERCHANTABILITY AND OF FITNESS FOR A PARTICULAR PURPOSE, STATUTORY WARRANTY OF NON-INFRINGEMENT, AND ANY OTHER WARRANTY THAT MAY ARISE BY REASON OF USAGE OF TRADE, CUSTOM, OR COURSE OF DEALING.

**Restrictions in Use**

IDT's ZSSC41xx SSC Evaluation Kits, consisting of the SSC Communication Board (SSC-CB), ZSSC41xx SSC Evaluation Board (ZSSC41xx SSC EB), SSC Sensor Replacement Board (SSC-SRB), and ZSSC41xx Evaluation Software, are designed for sensor module evaluation, laboratory setup, and module calibration development only. IDT's ZSSC41xx SSC Evaluation Kit hardware and software must not be used for module production or production test setups.

The related product ZSSC41xx SSC Mass Calibration System is designed only for development, evaluation, and laboratory setup of sensor modules with IDT Sensor Signal Conditioner ICs. The IDT Mass Calibration System hardware and software must not be used for module production and production test setups.

**Contents**

1. Introduction.....	3
2. Hardware Description.....	4
2.1 Kit Overview.....	4
2.2 ZSSC41xx SSC Evaluation Board Overview.....	5
3. Pin Descriptions for Board Connectors.....	7
3.1 Connections between the SSC Communication Board and the ZSSC41xx SSC Evaluation Board.....	7
3.2 Connections between the Optional Sensor Replacement Board and the ZSSC41xx SSC Evaluation Board.....	7
4. ZSSC41xx SSC Evaluation Board Schematic, Layout, and BOM.....	8
5. Related Websites and Software.....	13
6. Revision History.....	14

## List of Figures

Figure 1. ZSSC41xx SSC Evaluation Kit .....	3
Figure 2. Alternative User Sensor Module Connection Options .....	4
Figure 3. ZSSC41xx SSC Evaluation Board – Overview .....	5
Figure 4. ZSSC41xx SSC Evaluation Board Schematic .....	8
Figure 5. ZSSC41xx SSC Evaluation Board Layout – Silkscreen .....	10
Figure 6. ZSSC41xx SSC Evaluation Board Layout – Top Side.....	11
Figure 7. ZSSC41xx SSC Evaluation Board Layout – Bottom Side .....	12

## List of Tables

Table 1. ZSSC41xx SSC Evaluation Board Connectors, Switches, and LEDs .....	5
Table 2. Signal Connections: ZSSC41xx SSC Evaluation Board and SSC Communication Board .....	7
Table 3. Signal Connections: ZSSC41xx SSC Evaluation Board and Sensor Replacement Board.....	7
Table 4. Bill of Materials for ZSSC41xx SSC Evaluation Board .....	9

## 1. Introduction

The ZSSC41xx SSC Evaluation Board (ZSSC41xx SSC EB) is the main board in the modular ZSSC41xx SSC Evaluation Kits. These kits are designed for sensor module evaluation, laboratory setup, and module calibration development for the ZSSC41xx Sensor Signal Conditioner ICs (SSC), including the ZSSC4151, ZSSC4161, ZSSC4162, ZSSC4165, ZSSC4169 and ZSSC4175 (i.e., the device under test). Unless otherwise noted, all references to the ZSSC41xx apply to these products.

Refer to the product-specific kit user manuals for the specific contents, hardware setup details, software setup, basic operation, and order codes for the kits. Refer to the product-specific software manuals for full instructions for using the software for communication, calibration, configuration, and evaluation of the device under test (DUT). These manuals and the product-specific software are available for download on the IDT web pages for the specific products (see section 5).

The ZSSC41xx SSC Evaluation Kits contain the SSC Communication Board (SSC-CB), the ZSSC41xx SSC Evaluation Board, and the Sensor Replacement Board (SSC-SRB). These boards can be connected in the following configurations:

- The kit can be set up using the Sensor Replacement Board in place of a real sensor only for demonstration purposes as illustrated in Figure 1 (see details in section 2.1).
- The user's sensor can be connected on the KL1/KL2/KL3 screw terminals (see Figure 2) on the ZSSC41xx SSC Evaluation Board instead of using the Sensor Replacement Board.
- The "Sensor 1" or "Sensor 2" headers can be used to connect through the Evaluation Board to a complete user's module (including the user's sensor, ZSSC41xx DUT, and external circuit); in this case, do not use the 24-QFN socket or Sensor Replacement Board.  
Note: Sensor 2 is not applicable to the ZSSC4151.

Note: The SSC Communication Board (SSC-CB) must be version 4.1 with the current firmware version (see section 5) to function properly with the ZSSC41xx SSC Evaluation Board.

Note: On delivery, the ZSSC41xx SSC Evaluation Board has a "dummy" IC in the socket that must be replaced with an actual ZSSC41xx DUT. Refer to Figure 1 for the location of pin 1 for proper IC orientation.

**Figure 1. ZSSC41xx SSC Evaluation Kit**

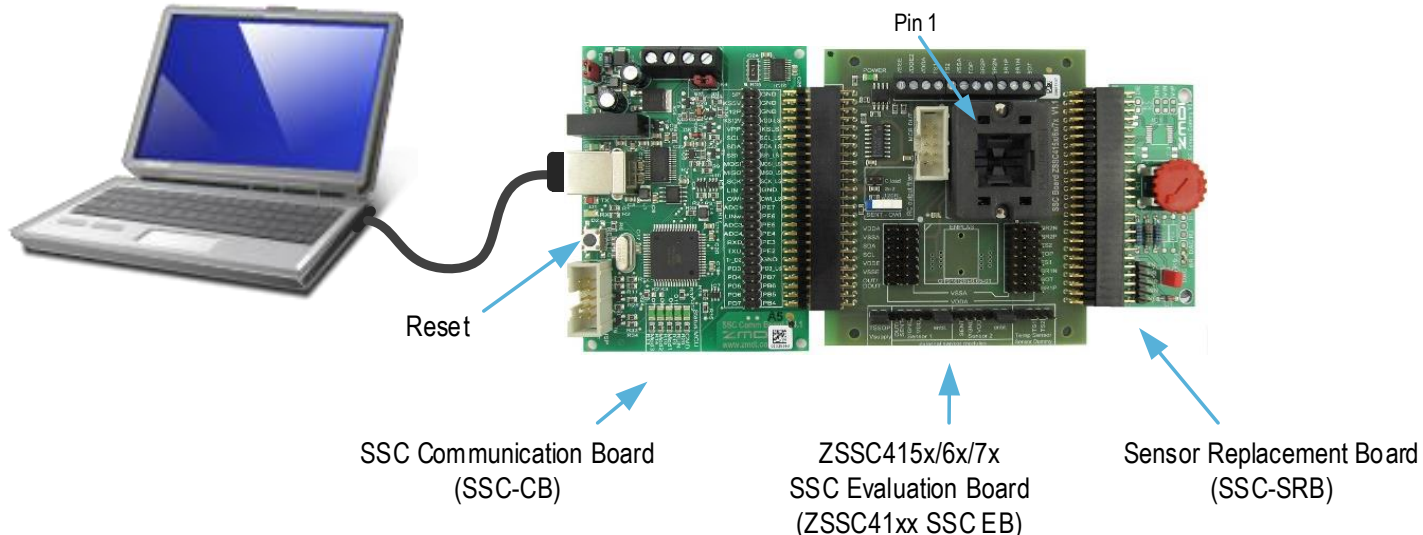

## 2. Hardware Description

### 2.1 Kit Overview

A primary purpose of the ZSSC41xx Evaluation Kit is communication between the user's computer and the ZSSC41xx DUT on the ZSSC41xx SSC EB. The computer sends commands and data via its USB port (configured as a virtual COM port) to the SSC-CB. The microcontroller on the SSC-CB interprets these commands and relays them to the ZSSC41xx in the I2C or OWI\* (One-Wire Interface) communication mode. Refer to the *SSC Communication Board Datasheet* for additional information about this board (see section 5).

The optional SSC-SRB provides a replacement for an actual resistive sensor and can be used for the first step of a calibration demonstration or a "dry-run" calibration. On the SSC-SRB, the sensor replacement signal is controlled by a potentiometer and provides a signal ranging from 2mV to 110mV to the analog front-end of the ZSSC41xx (BR1N and BR1P pins) and a temperature sensor signal from a 1N4148 diode to the ZSSC41xx temperature input (TS1 or TS2 pin, selectable by jumper K8, not applicable to the ZSSC4175D-01). Refer to the *SSC Sensor Replacement Board Datasheet* for additional information about this board (see section 5).

The SENT (Single Edge Nibble Transmission) interface signal (not applicable to the ZSSC4151) is a one-way transmission of values from the DUT to the SSC-CB microcontroller (intended for Normal Operation Mode only). The SENT interface allows high-resolution data transmission with a lower system cost than other serial data solutions. If enabled (see Table 1), the "Sensor 2" header can be used as a SENT input from an external user module for the ZSSC416x and ZSSC417x families (not applicable to the ZSSC4151). The "Sensor 1" header can be used for either a SENT input (not applicable to ZSSC4151) or an OWI interface (required for ZSSC4151) for an external user module.

**Figure 2. Alternative User Sensor Module Connection Options**

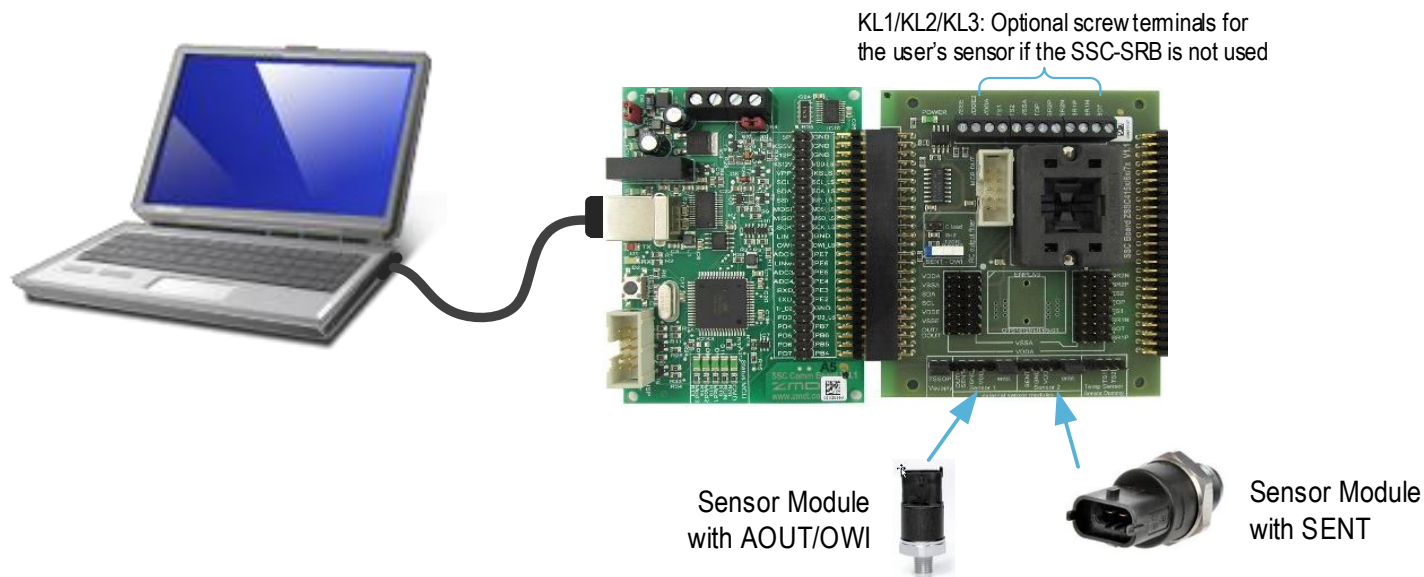

The microcontroller will forward any data bytes from the ZSSC41xx back to the user's computer via the USB connection. These bytes can be sensor and temperature readings to be displayed by the software on the computer, raw analog-to-digital converter (ADC) data used during calibration, or EEPROM data. The SSC-CB microcontroller controls the power signals required for entering the Command Mode.

The ZSSC41xx power (VDDE) can be supplied from the CB KS5V power supply (jumper K7 closed; see Figure 3) or from an external supply (VDDE2) connected across the VDDE2 and VSSE post on the KL1 screw terminal (jumper K7 must be open).

**Important:** Ensure that jumper K7 is open before connecting an external VDDE2 power supply.

If connected, the VDDE2 supply can be switched ON or OFF by the CB-controlled KS5V signal and the IC4 power MOSFET as needed to establish OWI communication.

\* OWI is also referred to as ZACwire™.

The reset button on the SSC-CB (see Figure 1) sets the controller to its initial state. Note that any SSC-CB port settings will be overwritten. The Mass Calibration Board DUT connector is intended for connecting the ZSSC41xx SSC Evaluation Board to a Mass Calibration Board (MCB) for evaluation. The connector provides an I2C and OWI interface through the MCB and provides power to it.

**Important:** Do not connect the SSC-CB to the ZSSC41xx SSC EB if the MCB is used.

## 2.2 ZSSC41xx SSC Evaluation Board Overview

The operation of the ZSSC41xx SSC Evaluation Board is similar for all applicable products except as follows:

- For the ZSSC4151, the S1 jumper identified in Figure 3 must be in the OWI position. SENT transmission is not applicable to this product.
- For the ZSSC4151, the DOUT labels on the board and callouts in Figure 3 and in the schematic in Figure 4 refer to the ZSSC4151's AOUT pin.
- The BR2N and BR2P pins do not apply to the ZSSC4151.

**Figure 3. ZSSC41xx SSC Evaluation Board – Overview**

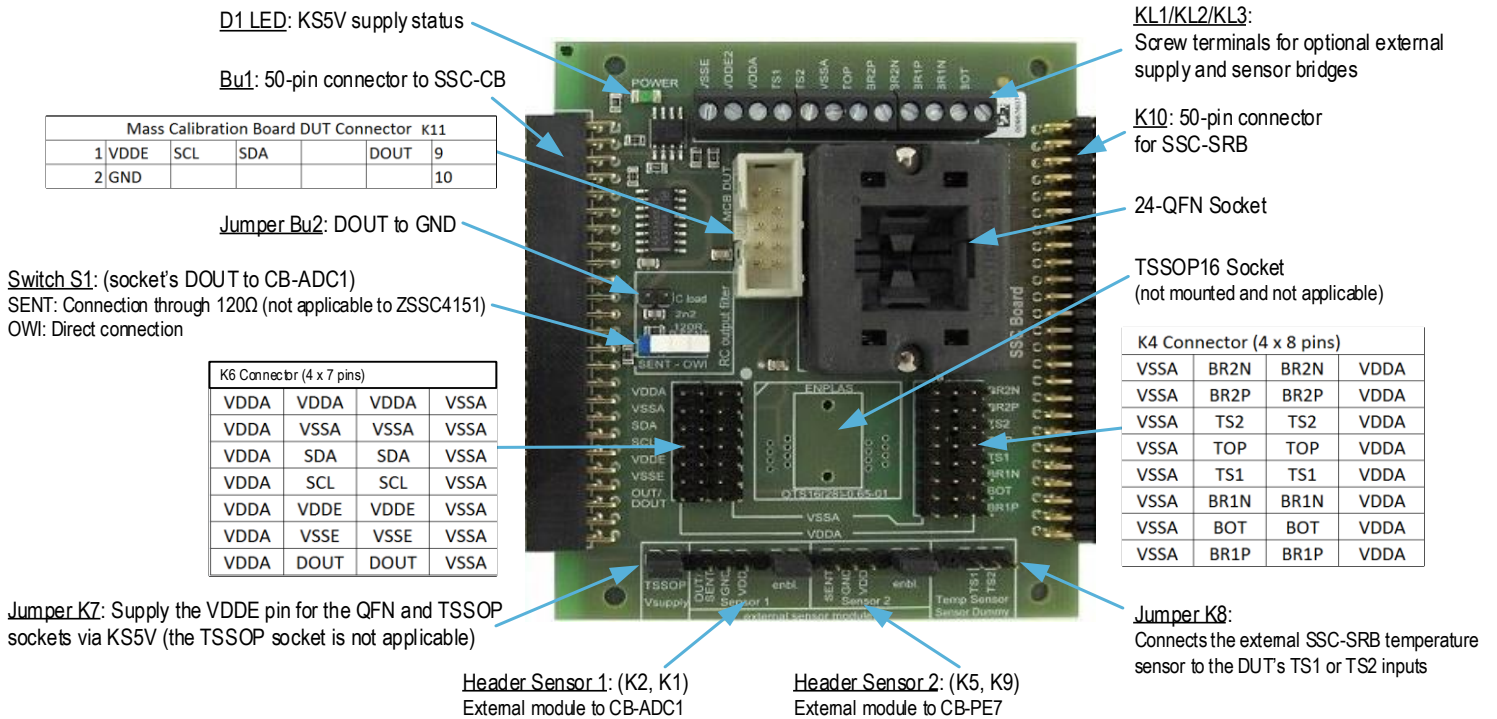

**Table 1. ZSSC41xx SSC Evaluation Board Connectors, Switches, and LEDs**

Name	Description
D1	Status LED for the KS5V supply. Its forward current is not included in the measured supply current.
Bu1	50-pin female connector connected to the SSC-CB. See section 3.1 for descriptions of the signals on Bu1.
K10	50-pin male connector to the SSC-SRB. See section 3.2 for descriptions of the signals on K10.

Name	Description
KL1	On-board screw terminal for GND (VSSE), VDDE2 (to VDDE), VDDA, and TS1 connections. (Note: The TS1 pin is not applicable to the ZSSC4175D-01.)
KL2	On-board screw terminal for TS2, VSSA, TOP, and BR2P. (Note: The BR2P pin is not applicable to the ZSSC4151 and the TS1 pin to the ZSSC4175D-01.)
KL3	On-board screw terminal for BR2N, BR1P, BR1N, and BOT. (Note: The BR2N pin is not applicable to the ZSSC4151.)
K1, K9	Powers (enables) the headers for connecting external Sensor 1 and Sensor 2 modules (K2 and K5 respectively) via KS5V.
K2, K5	Headers for connections for external Sensor 1 or Sensor 2 modules. Sensor 2 (K5) is intended only for SENT input one-way transmission (Sensor 2 is not applicable to the ZSSC4151). The ZSSC4151 requires the OWI interface to use Sensor 1 (K2).
K4, K6	Header strips for access to all ZSSC41xx signals; K6 can be used to connect directly to the DUT for in-circuit programming.
K7	2-pin header for connecting the KS5V supply to the VDDE pin (leave jumper open when the external power supply VDDE2 is connected); provides test points for simple supply current measurements.
K8	Connects the external SSC-SRB temperature sensor to the DUT's TS1 or TS2 inputs. (Note: The TS1 and TS2 pins are not applicable to the ZSSC4175D-01.)
S1	Switch that is used for interface selection between OWI and SENT. (Set to OWI for the ZSSC4151.)
24-QFN	Socket for inserting the 24-QFN 4mm × 4mm ZSSC41xx DUT.
K11	Mass Calibration Board (MCB) DUT connector.



### 3. Pin Descriptions for Board Connectors

#### 3.1 Connections between the SSC Communication Board and the ZSSC41xx SSC Evaluation Board

Table 2 gives the descriptions for the signals on the Bu1 connector (see Figure 3) that are applicable to the ZSSC41xx.

**Table 2. Signal Connections: ZSSC41xx SSC Evaluation Board and SSC Communication Board**

Bu1 Pin Name	Bu1 Pin	Description
5P	1	5V constant power supply.
KS5V	3	Power supply controlled by the microcontroller on the SSC-CB.
GND	2, 4, 6	Ground connection.
SCL, SDA	11, 13	I2C interface, 5V logic.
MOSI, MISO, SCK	17, 19, 21	SPI interface, 5V logic (used for ZSSC41xx SSC EB identification by I2C).
OWI	25	Bi-directional I/O port with ZSSC41xx-internal pull-up resistors; a pull-up resistor from KS5V with a resistance of 4.7kΩ (on the SSC-CB) can be enabled by setting the SSC-CB microcontroller port pin G3 low via the <i>PS_G30</i> terminal command.
ADC1	27	One-Wire Interface (OWI) connection to the SSC-CB's ADC1 (PA1).
PE7	28	Bi-directional I/O port with internal pull-up resistors.
Tr_PD2	39	Pull-up from KS5V with 510Ω resistor (R2) to the OWI line; enabled by setting the SSC-CB microprocessor port pin D2 low via the <i>PS_D20</i> terminal command during OWI communication.
PD4	43	Bi-directional I/O port with internal pull-up resistors.
PD6, PD7	47, 49	I2C 8-bit serial shift registers settings; set by the ZSSC41xx Evaluation Software.

#### 3.2 Connections between the Optional Sensor Replacement Board and the ZSSC41xx SSC Evaluation Board

Table 3 gives the descriptions for applicable signals on the K10 connector (see Figure 3).

**Table 3. Signal Connections: ZSSC41xx SSC Evaluation Board and Sensor Replacement Board**

K10 Pin Name	K10 Pin	Description
TOP	39, 45	Bridge and temperature sensor positive supply voltage
TS_U	41	Temperature sensor input (diode 1N4148)
BOT	43	Bridge negative supply voltage
BR1P	47	Bridge positive signal
BR1N	49	Bridge negative signal

## 4. ZSSC41xx SSC Evaluation Board Schematic, Layout, and BOM

Figure 4. ZSSC41xx SSC Evaluation Board Schematic

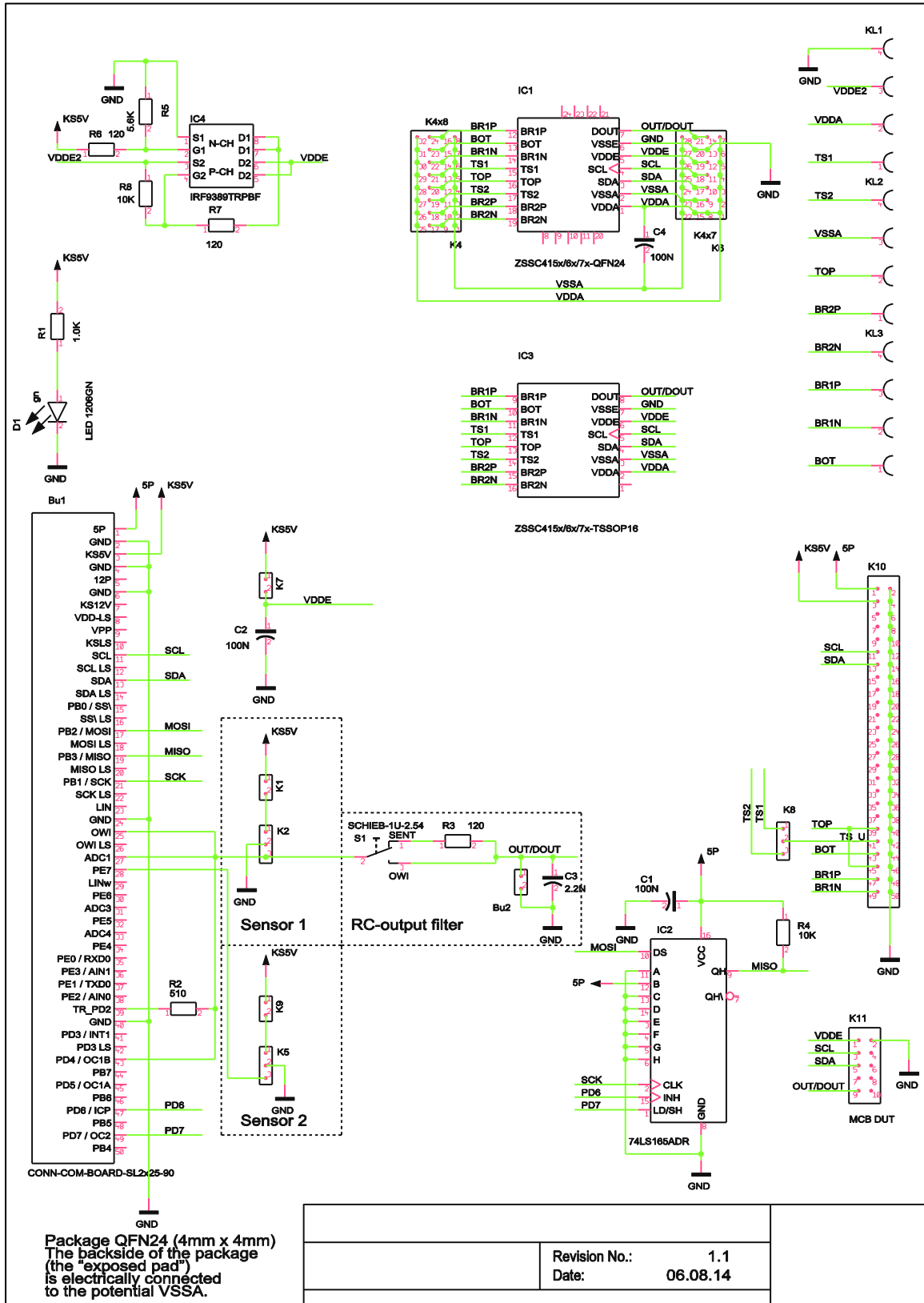



**Table 4. Bill of Materials for ZSSC41xx SSC Evaluation Board**

Designator	Value	Package	Manufacturer P/N	Supplier	Quantity
Bu1	SL2x25-90	WBUL50-GEW	BL 2X25W 2.54	Reichelt	
Bu2	K1X2	1X02	SL 1X36G 2.54 z.B.	Reichelt	1
C1	100N	0805	X7R-G0805 100N	Reichelt	1
C2	100N	0805	X7R-G0805 100N	Reichelt	1
C3	2.2N	0805	X7R-G0805 2.2N	Reichelt	1
C4	100N	0805	X7R-G0805 100N	Reichelt	1
D1	LED 1206GN	1206-DIODE	SMD-LED 1206 GN	Reichelt	1
IC1	24-QFN Socket	24LQ50K14040	24LQ50K14040	Plastronics	1
IC2	74LS165ADR	SOIC16_150MIL	296-31854-1-ND	Digi-Key	1
IC4	IRF9389TRPBF	SMD8	IRF9389TRPBFCT-ND	Digi-Key	1
K1	K1X2	1X02	SL 1X36G 2.54 z.B.	Reichelt	1
K2	K1X3	1X03	M20-9990346	Farnell	1
K4	K4x8	4X08	M20-9980846	Farnell	1
K5	K1X3	1X03	M20-9990346	Farnell	1
K6	K4x7	4X07	M20-9980745	Farnell	1
K7	K1X2	1X02	SL 1X36G 2.54 z.B.	Reichelt	1
K8	K1X3	1X03	M20-9990346	Farnell	1
K9	K1X2	1X02	SL 1X36G 2.54 z.B.	Reichelt	1
K10	WSL-50POL_2x25	2X25-90	TSW-125-08-T-D-RA	Farnell	1
K11	MCB DUT	LH-10	WSL 10G	Reichelt	1
KL1	AKL 059-04	KLEMME-4RM3.5	AKL 059-04	Reichelt	1
KL2	AKL 059-04	KLEMME-4RM3.5	AKL 059-04	Reichelt	1
KL3	AKL 059-04	KLEMME-4RM3.5	AKL 059-04	Reichelt	1
R1	1.0K	0805	SMD-0805 1.00K	Reichelt	1
R2	510	0805	1400040	Farnell	1
R3	120	0805	SMD-0805 xxx	Reichelt	1
R4	10K	0805	SMD-0805 xxx	Reichelt	1
R5	5.6K	0805	SMD-0805 xxx	Reichelt	1
R6	120	0805	SMD-0805 xxx	Reichelt	1
R7	120	0805	SMD-0805 xxx	Reichelt	1

Designator	Value	Package	Manufacturer P/N	Supplier	Quantity
R8	10K	0805	SMD-0805 xxx	Reichelt	1
S1	SCHIEB-1U-2.54	SCHIEB-1U-2.5	SS ESP101	Reichelt	1
Pad	Silicon Pads		1165068	Farnell	4

**Figure 5. ZSSC41xx SSC Evaluation Board Layout – Silkscreen**

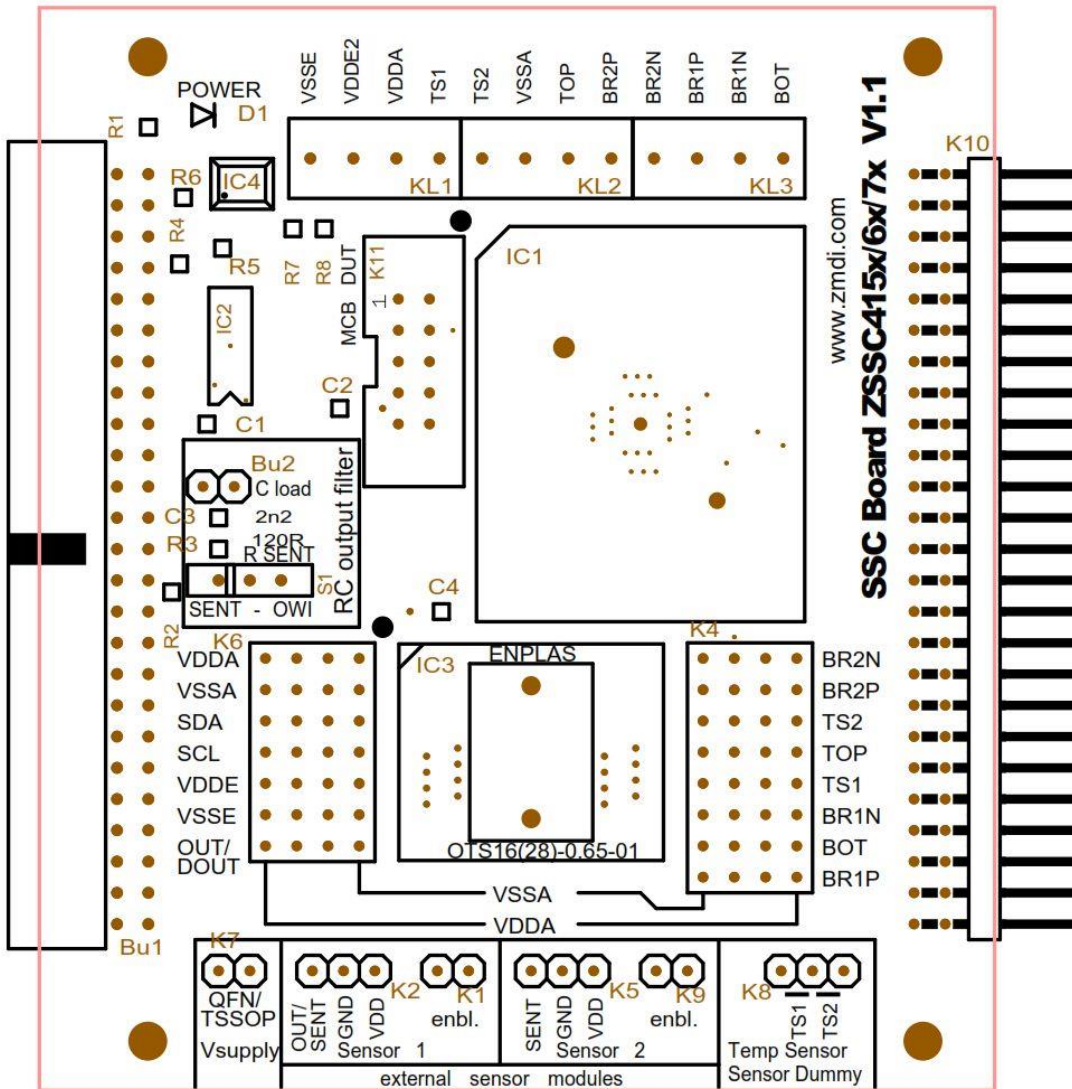

Figure 6. ZSSC41xx SSC Evaluation Board Layout – Top Side

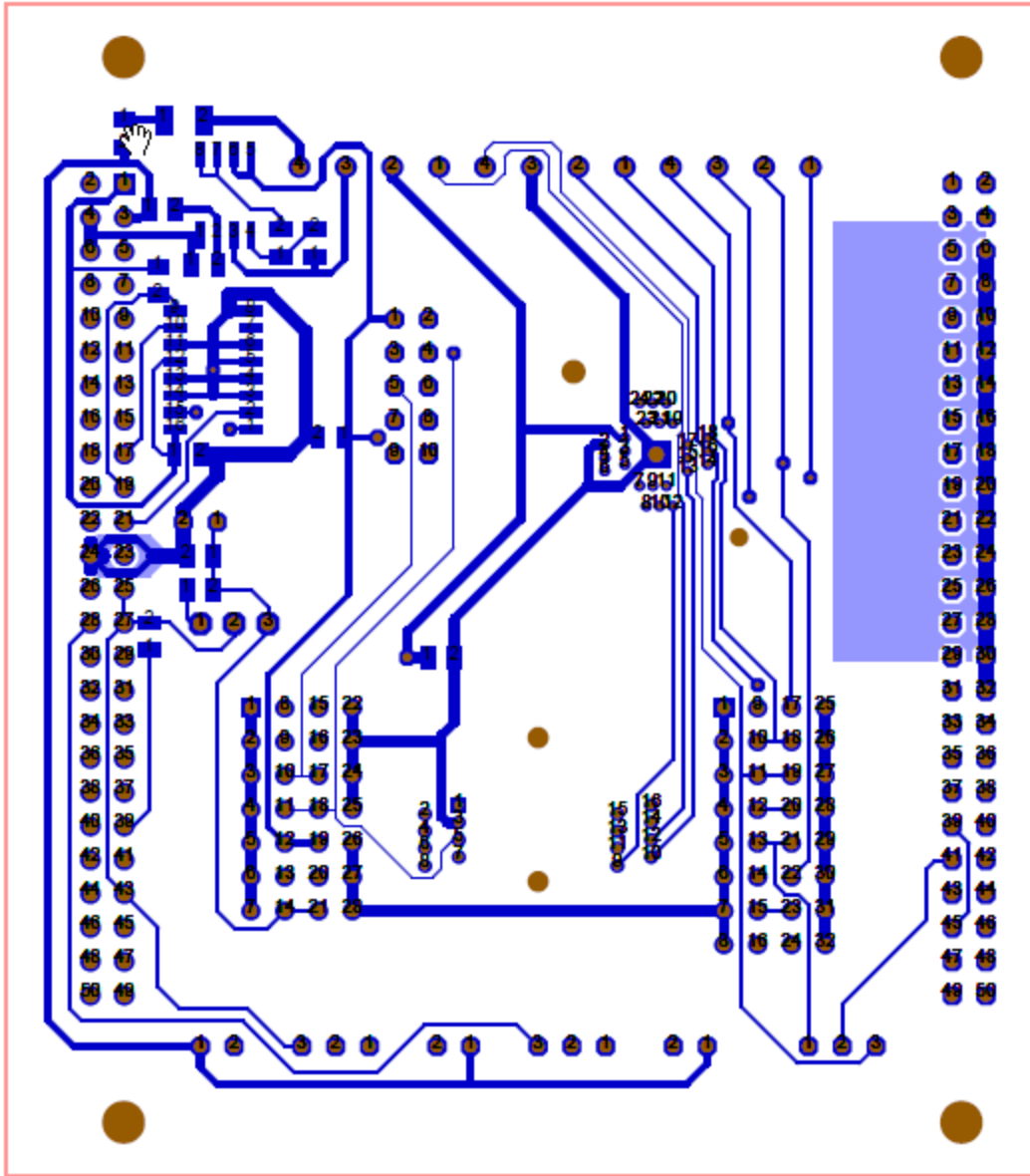
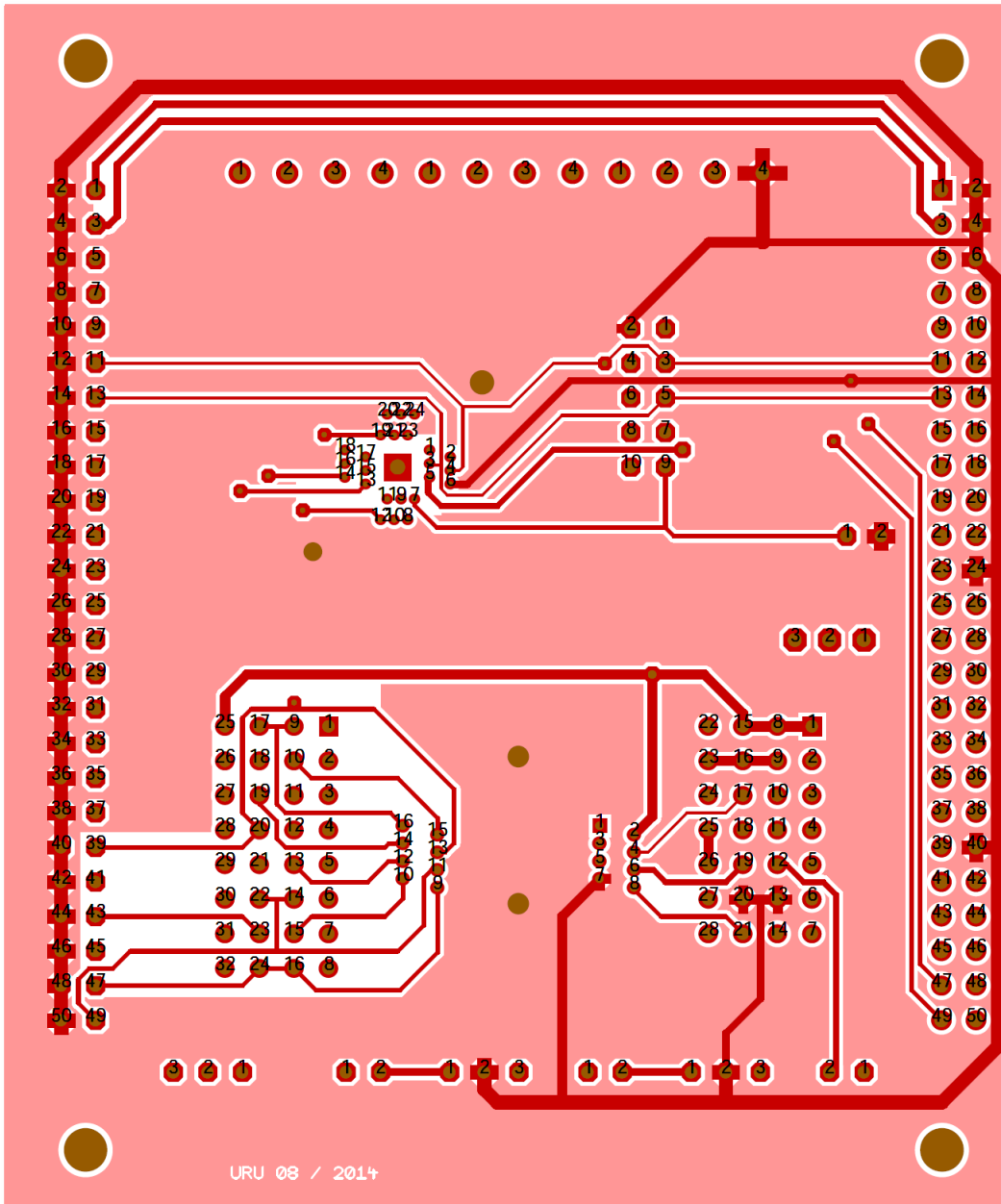

Figure 7. ZSSC41xx SSC Evaluation Board Layout – Bottom Side



## 5. Related Websites and Software

Visit the specific product pages on IDT's website [www.IDT.com](http://www.IDT.com) to download software/firmware, related documents, and the latest version of this document, or contact IDT via the contact information on the last page.

Product	IC Product Web Page	Kit Product Web Page
ZSSC4151	<a href="http://www.IDT.com/ZSSC4151">www.IDT.com/ZSSC4151</a>	<a href="http://www.IDT.com/zssc415xkit">www.IDT.com/zssc415xkit</a>
ZSSC4161	<a href="http://www.IDT.com/ZSSC4161">www.IDT.com/ZSSC4161</a>	<a href="http://www.IDT.com/zssc416xkit">www.IDT.com/zssc416xkit</a>
ZSSC4162	<a href="http://www.IDT.com/ZSSC4162">www.IDT.com/ZSSC4162</a>	<a href="http://www.IDT.com/zssc416xkit">www.IDT.com/zssc416xkit</a>
ZSSC4165	<a href="http://www.IDT.com/ZSSC4165">www.IDT.com/ZSSC4165</a>	<a href="http://www.IDT.com/zssc416xkit">www.IDT.com/zssc416xkit</a>
ZSSC4169	<a href="http://www.IDT.com/ZSSC4169">www.IDT.com/ZSSC4169</a>	<a href="http://www.IDT.com/zssc416xkit">www.IDT.com/zssc416xkit</a>
ZSSC4175	<a href="http://www.IDT.com/ZSSC4175">www.IDT.com/ZSSC4175</a>	<a href="http://www.IDT.com/zssc417xkit">www.IDT.com/zssc417xkit</a>
SSC Communication Board (SSC-CB)	<a href="http://www.IDT.com/ssc-cb">www.IDT.com/ssc-cb</a>	
Sensor Replacement Board (SSC-SRB)	<a href="http://www.IDT.com/ssc-srb">www.IDT.com/ssc-srb</a>	

## 6. Revision History

Revision Date	Description of Change
May 13, 2019	<ul style="list-style-type: none"> <li>▪ Complete document revision.</li> <li>▪ Ordering code table removed.</li> <li>▪ Product name changed to ZSSC41xx.</li> <li>▪ Minor edits and template update.</li> </ul>
February 1, 2017	<ul style="list-style-type: none"> <li>▪ Merger of separate documents for ZSSC4151 and ZSSC416x/7x and rebranding for IDT. Revision reference is now the document revision release date.</li> <li>▪ Addition of bill of materials and board layout images.</li> <li>▪ Addition of Figure 2 for user module connections.</li> <li>▪ Addition of order codes.</li> <li>▪ Minor edits and re-organization.</li> </ul>