



CAVITY

Bandpass Filter ZVBP MODEL SERIES

50Ω DC to 57 GHz

THE BIG DEAL

- Very Low Insertion Loss with Excellent Power Handling
- Fast Roll-Off with Wide Stopband
- Passbands Up to 36 GHz
- Stopband Up to 57 GHz

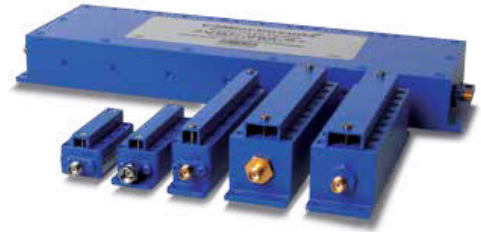

PRODUCT OVERVIEW

Mini-Circuits' coaxial cavity filters are designed by implementing resonant structures with very high Q and are ideal for narrow-band, high-selectivity applications. These designs can provide bandwidths as narrow as 0.5% with very high selectivity and excellent low noise floor. Low insertion loss combined with excellent power handling makes them well-suited for transmitter and receiver front ends. Advanced filter design and construction enables stopband width greater than 3x the center frequency.

Mini-Circuits' coaxial cavity filters feature a special protective assembly to prevent accidental de-tuning that would otherwise require expensive replacement or return to factory for re-tuning. Precise machining allows realization of cavity filters with small form factors for applications where size is critical.

KEY FEATURES

Feature	Advantages
Low insertion loss	Low signal loss results in better SNR in receiver front end and better power delivery to antenna in transmitter.
Fast roll-off	Higher selectivity results in better adjacent channel rejection and dynamic range
Wide stopband	Wide spur free band results in better receiver sensitivity
High power handling	Well suited for transmitter application
Protective assembly	Prevents accidental de-tuning of precisely tuned resonant circuit





CAVITY

Bandpass Filter

ZVBP-3R25G-S+

Mini-Circuits

50Ω 3000 to 3500 MHz SMA-Female

FEATURES

- Low Insertion Loss of 0.3dB Typ.
- Good Return Loss of 20dB Typ.
- Good Rejection
- Stopband up to 7800 MHz



Generic photo used for illustration purposes only

Model No.	ZVBP-3R25G-S+
Case Style	YM3241
Connectors	SMA-FEMALE

APPLICATIONS

- Test & Measurement Equipment
- R&D Lab, Production, and OTA Test Systems

+RoHS Compliant

The +Suffix identifies RoHS Compliance. See our website for methodologies and qualifications

ELECTRICAL SPECIFICATIONS AT 25°C

Parameter	F#	Frequency (MHz)	Min.	Typ.	Max.	Units
Center Frequency	Fc	—	—	3250	—	MHz
Passband	Insertion Loss	F1-F2	3000 - 3500	0.3	0.7	dB
	Return Loss	F1-F2	3000 - 3500	14	19	dB
Stop Band, Lower	Rejection	DC-F3	DC - 2200	55	61	—
		F3-F4	2200 - 2600	35	40	—
Stop Band, Upper	Rejection	F4-F5	2600 - 2850	10	16	—
		F6-F7	3650 - 3800	10	16	—
Stop Band, Upper	Rejection	F7-F8	3800 - 4100	25	32	—
		F8-F9	4100 - 7800	45	51	—

ABSOLUTE MAXIMUM RATINGS

Parameter	Ratings
Operating temperature	-40°C to +85°C
Storage temperature	-55°C to +100°C
RF Power Input	25W at 25°C

Permanent damage may occur if any of these limits are exceeded
Input and output ports are DC short to ground.

TYPICAL FREQUENCY RESPONSE

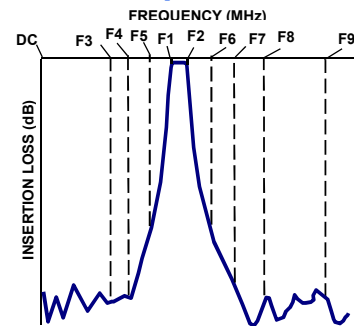

FUNCTIONAL DIAGRAM

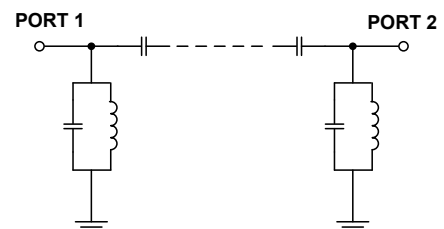

Mini-Circuits



CAVITY

Bandpass Filter

ZVBP-3R25G-S+

Mini-Circuits

COAXIAL CONNECTIONS

PORT 1	SMA-Female
PORT 2	SMA-Female

OUTLINE DRAWING

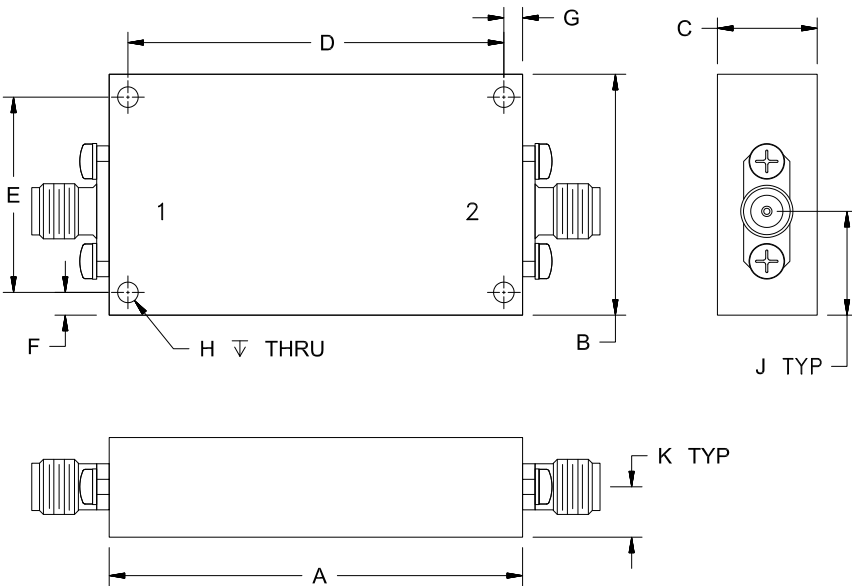

OUTLINE DIMENSIONS (Inches) mm

A	B	C	D	E	F
1.99	1.16	.48	1.810	.940	.11
50.5	29.5	12.2	45.97	23.88	2.8
G	H	J	K		Wt.
.09	.100	.50	.24		grams
2.3	2.54	12.7	6.2		87

Note. Please refer to case style drawing for details

