



COAXIAL

Low Noise Amplifier

ZX60-3011+

50Ω

400 to 3000 MHz

FEATURES

- High Dynamic Range
- Wide Bandwidth, 400 to 3000 MHz
- Low Noise Figure 1.5 dB typ.
- 1dB Compression, +21 dBm
- Medium IP3
- Reverse voltage connection protected
- Over-voltage transient protected
- Low Cost
- Protected by US patent 6,790,049



Generic photo used for illustration purposes only

Model No.	ZX60-3011+
Case Style	GC957
Connectors	SMA

+RoHS Compliant

The +Suffix identifies RoHS Compliance. See our website for methodologies and qualifications

APPLICATIONS

- Buffer Amplifier
- LO Amplifiers for mixers
- Cellular
- PCN
- General purpose small signal

ELECTRICAL SPECIFICATIONS AT 25°C

Parameter	Condition (MHz)	Min	Typ.	Max.	Units
Frequency		400		3000	MHz
Noise Figure	400-1000	-	1.4	2.5	dB
	1000-1700	-	1.5	2.5	
	1700-2400	-	1.7	2.6	
	2400-3000	-	1.8	2.8	
Gain	400-1000	12	15.0	-	dB
	1000-1700	11	13.5	-	
	1700-2400	9	11.5	-	
	2400-3000	7.5	10.0	-	
Gain Flatness	400-1000	-	±.70	-	dB
	1000-1700	-	±1.0	-	
	1700-2400	-	±1.0	-	
	2400-3000	-	±.70	-	
Output Power at 1dB compression	400-1000	19.5	21.5	-	dBm
	1000-1700	19.5	21.5	-	
	1700-2400	18.5	21.0	-	
	2400-3000	18.0	20.4	-	
Output third order intercept point		-	31	-	dBm
Input VSWR		-	1.7	-	:1
Output VSWR	400-3000	-	1.6	-	:1
DC Supply Voltage		-	12	-	V
Supply Current		-	120	-	mA

REV. H
ECO-016035
ZX60-3011+
MCL NY
221206





COAXIAL

Low Noise Amplifier

ZX60-3011+

Mini-Circuits

50Ω

400 to 3000 MHz

MAXIMUM RATINGS

Parameter	Ratings
Operating Temperature	-40°C to 85°C Case -40°C to 60°C Ambient
Storage Temperature	-55°C to 100°C
DC Voltage ¹	+6.5V Min. to +15V Max
Input RF Power (no damage)	+15 dBm
Power Dissipation	1.12W typ. at +12V

Permanent damage may occur if any of these limits are exceeded.
 1. Other voltages available in the +6.5 to +20V range. Contact Factory.

OUTLINE DRAWING

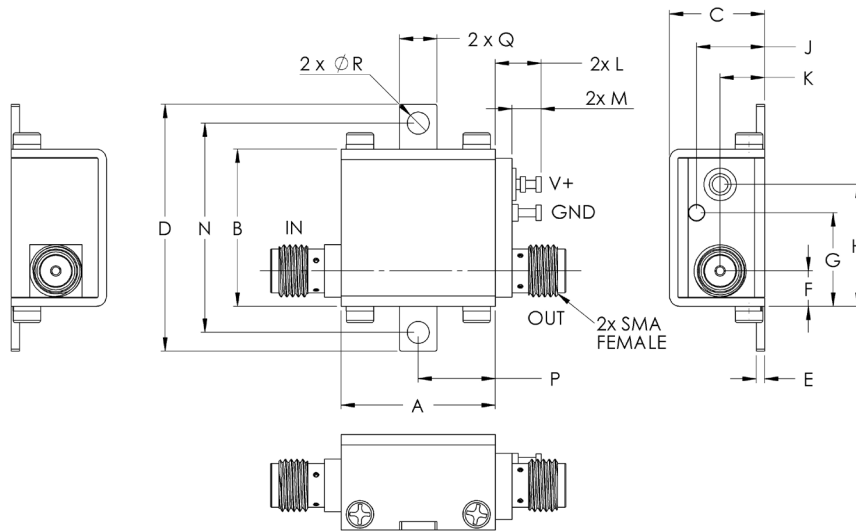

! NOTE: When soldering the DC connections, caution must be used to avoid overheating the DC terminal.
 See Application Note. [AN-40-010](#).

OUTLINE DIMENSIONS (Inches)

A	B	C	D	E	F	G	H	J	K	L	M	N	P	Q	R	wt
																grams
.74	.75	.46	1.18	.04	.17	.45	.59	.33	.21	.22	.14	1.00	.37	.18	.106	23.0
18.80	19.1	11.68	30.0	1.02	4.32	11.4	14.99	8.38	5.33	5.59	3.56	25.40	9.40	4.57	2.69	

