

## Description

The ZXCT21x series are high-precision current-shunt monitor with different choices of gain options to measure low-voltage drop (10mV) across a small shunt resistor with minimal error. This enables high accuracy of large current measurement and reduces a power loss caused by the measurement at common-mode voltages from -0.3V to 26V.

OUT pin is a voltage proportional to the load current. It can then be processed with an ADC. There are six fixed gains available: 50, 75, 100, 200, 500, and 1000 V/V respectively. This device is designed with zero-drift architecture and is manufactured by post trim technology to achieve low offset voltage, low gain drift and low gain error among full temperature range for precise measurement.

The ZXCT21x operates from a single 2.7V to 26V power supply with a maximum of 100µA of supply current from -40°C to +125°C, and is offered in SOT363 and U-QFN1418-10 package.

## Features

- Supply Voltage Range: 2.7V to 26V
- Temperature Range: -40°C to +125°C
- Wide Common-Mode Range: -0.3V to 26V
- Support Shunt Drops of 10mV Full-Scale
- Gain Error (Maximum Overtemperature)
  - A and B Version: ±0.8%
  - C Version: ±0.5%
- Low Offset Voltage: ±30µV (max)
- Quiescent Current: 100µA (max)
- Low Gain Error Drift: 10ppm/°C (max)
- Rail-to-Rail Output Capacity
- Choice of Gains:
  - ZXCT210: 200V/V
  - ZXCT211: 500V/V
  - ZXCT212: 1000V/V
  - ZXCT213: 50V/V
  - ZXCT214: 100V/V
  - ZXCT215: 75V/V
- Package: 6-pin SOT363 and 10-pin U-QFN1418-10
- **Totally Lead-Free & Fully RoHS Compliant (Notes 1 & 2)**
- **Halogen and Antimony Free. “Green” Device (Note 3)**
- **An automotive-compliant part is available under separate datasheet ([ZXCT21xQ](#))**

Notes: 1. No purposely added lead. Fully EU Directive 2002/95/EC (RoHS), 2011/65/EU (RoHS 2) & 2015/863/EU (RoHS 3) compliant.  
 2. See <https://www.diodes.com/quality/lead-free/> for more information about Diodes Incorporated's definitions of Halogen- and Antimony-free, "Green" and Lead-free.  
 3. Halogen- and Antimony-free "Green" products are defined as those which contain <900ppm bromine, <900ppm chlorine (<1500ppm total Br + Cl) and <1000ppm antimony compounds.

## Pin Assignments

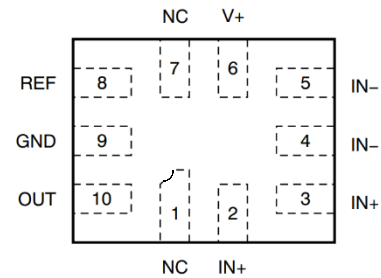

U-QFN1418-10

### Top View

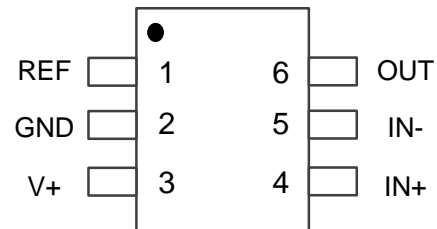

SOT363

## Applications

- Notebook computers
- Server farms
- Telecoms
- Current sensing (high-side/low-side)
- Battery charging and discharging
- High-performance video cards
- Industrial power supplies
- Instrumentation
- Control systems
- Metering

**Typical Applications Circuit**

Part Number	Version	Gain	Gain Error	V <sub>OS</sub>	Gain Drift
		V/V	%	μV	ppm/°C
ZXCT210	A	200	0.8	±35	10
ZXCT210	B	200	0.8	±30	10
ZXCT210	C	200	0.5	±30	10
ZXCT211	A	500	0.8	±35	10
ZXCT211	B	500	0.8	±30	10
ZXCT211	C	500	0.5	±30	10
ZXCT212	A	1000	0.8	±35	10
ZXCT212	B	1000	0.8	±30	10
ZXCT212	C	1000	0.5	±30	10
ZXCT213	A	50	0.8	±100	10
ZXCT213	B	50	0.8	±90	10
ZXCT213	C	50	0.5	±90	10
ZXCT214	A	100	0.8	±75	10
ZXCT214	B	100	0.8	±60	10
ZXCT214	C	100	0.5	±60	10
ZXCT215	A	75	0.8	±75	10
ZXCT215	B	75	0.8	±60	10
ZXCT215	C	75	0.5	±60	10

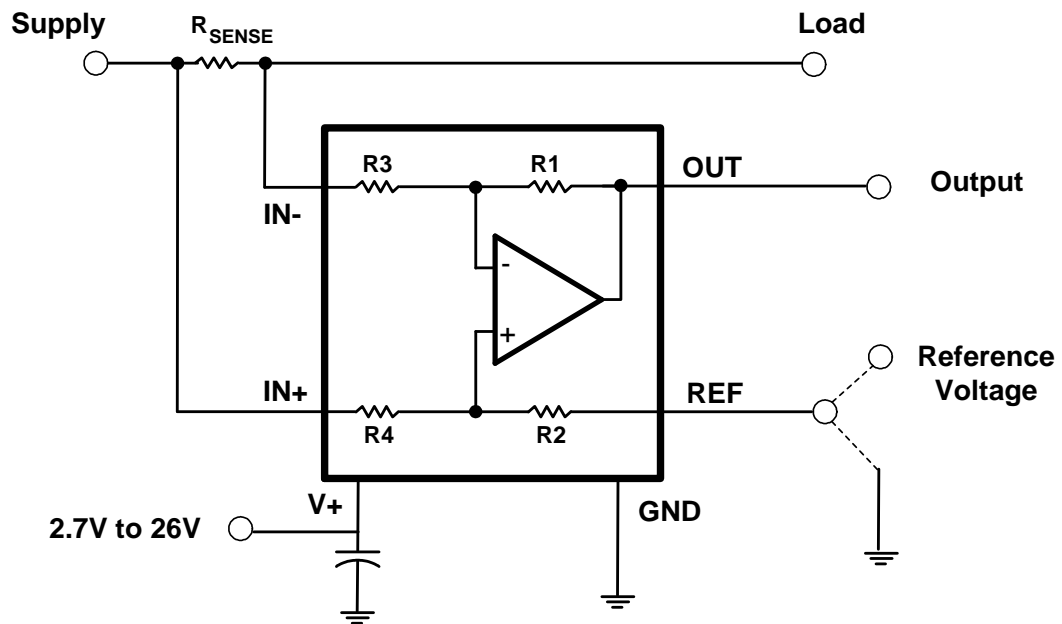

$$V_{OUT} = (I_{LOAD} \times R_{SENSE}) \text{ GAIN} + V_{REF}$$

## Pin Descriptions

Pin Name	Pin Number		I/O	Description
	SOT363	U-QFN1418-10		
REF	1	8	Analog input	Reference voltage, 0V to V+
GND	2	9	—	Ground
V+	3	6	Power	Power supply, 2.7V to 26V
IN+	4	2, 3	Analog input	Connect to supply side of shunt resistor.
IN-	5	4, 5	Analog input	Connect to load side of shunt resistor.
OUT	6	10	Analog output	Output voltage
NC	—	1, 7	—	Not internally connected. Leave floating or connect to ground.

## Absolute Maximum Ratings (@T<sub>A</sub> = +25°C, unless otherwise specified.) (Notes 4, 5)

Description	Rating	Unit
Supply Voltage (V+)	26	V
Analog Inputs IN+, IN-	Differential (IN+)-(IN-)	-26 to 26
	Common Mode	GND - 0.3 to 26
REF Input Voltage	GND - 0.3 to (V+) + 0.3	V
Output	GND - 0.3 to (V+) + 0.3	V
Input Current Into All Pins (Note 5)	5	mA
ESD Human Body Model ESD Protection (HBM)	±5	kV
ESD Charged Device Model ESD Protection (CDM)	±1.5	kV
Operating Ambient Temperature, T <sub>A</sub>	-40 to +125	°C
Operating Junction Temperature, T <sub>J</sub>	-40 to +150	°C
Storage Temperature, T <sub>STG</sub>	-65 to +150	°C

- Notes:
- Stresses greater than the *Absolute Maximum Ratings* specified above can cause permanent damage to the device. These are stress ratings only; functional operation of the device at these or any other conditions exceeding those indicated in this specification is not implied. Device reliability can be affected by exposure to absolute maximum rating conditions for extended periods of time.
  - Input voltage at any pin can exceed the voltage shown if the current at that pin is limited to 5mA.

## Thermal Information (Note 6)

Symbol	Parameter	Value	Unit
R <sub>θJA</sub>	Junction-to-Ambient Thermal Resistance, SOT363	228	°C/W
R <sub>θJC</sub>	Junction-to-Case Thermal Resistance, SOT363	64	
R <sub>θJA</sub>	Junction-to-Ambient Thermal Resistance, U-QFN1418-10	115	
R <sub>θJC</sub>	Junction-to-Case Thermal Resistance, U-QFN1418-10	50	

- Note: 6. R<sub>θJA</sub> and R<sub>θJC</sub> are measured at T<sub>A</sub> = +25°C on a high effective thermal conductivity four-layer test board per JEDEC 51-7.

## Recommended Operating Conditions (Note 7)

Symbol	Parameter	Min	Typ	Max	Unit
V <sub>CM</sub>	Common-Mode Input Voltage	-0.3	12	26	V
V <sub>S</sub>	Operating Supply Voltage (Applied to V+)	2.7	5	26	V
T <sub>A</sub>	Operating Ambient Temperature	-40	—	+125	°C

- Note: 7. Refer to the typical application circuit.

**Electrical Characteristics** ( $T_A = +25^\circ\text{C}$ ,  $V_S = 5\text{V}$ ,  $V_{IN+} = 12\text{V}$ ,  $V_{SENSE} = V_{IN+} - V_{IN-}$ , and  $V_{REF} = V_S/2$ , unless otherwise specified.)

Symbol	Parameter		Test Conditions	Min	Typ	Max	Unit
$V_{CM}$	Common-Mode Input		$T_A = -40^\circ\text{C}$ to $+125^\circ\text{C}$	-0.3	—	26	V
CMRR	Common-Mode Rejection	ZXCT210, ZXCT211, ZXCT212, ZXCT214, ZXCT215	$V_{IN+} = 0\text{V}$ to $26\text{V}$ , $V_{SENSE} = 0\text{mV}$ , $T_A = -40^\circ\text{C}$ to $+125^\circ\text{C}$	100	120	—	dB
		ZXCT213	$V_{IN+} = 0\text{V}$ to $26\text{V}$ , $V_{SENSE} = 0\text{mV}$ , $T_A = -40^\circ\text{C}$ to $+125^\circ\text{C}$	95	120	—	
$V_{OS}$	Offset Voltage, RTI (Note 8)	ZXCT210, ZXCT211, ZXCT212	$V_{SENSE} = 0\text{mV}$	—	$\pm 0.55$	$\pm 35$	$\mu\text{V}$
		ZXCT213	$V_{SENSE} = 0\text{mV}$	—	$\pm 5$	$\pm 100$	$\mu\text{V}$
		ZXCT214, ZXCT215	$V_{SENSE} = 0\text{mV}$	—	$\pm 1$	$\pm 75$	$\mu\text{V}$
$dV_{OS}/dT$	$V_{OS}$ vs. Temperature		$T_A = -40^\circ\text{C}$ to $+125^\circ\text{C}$	—	0.1	0.5	$\mu\text{V}/^\circ\text{C}$
PSRR	Power Supply Rejection		$V_S = 2.7\text{V}$ to $18\text{V}$ , $V_{IN+} = 18\text{V}$ , $V_{SENSE} = 0\text{mV}$	—	$\pm 0.1$	$\pm 10$	$\mu\text{V}/\text{V}$
$I_B$	Input Bias Current		$V_{SENSE} = 0\text{mV}$	—	28	35	$\mu\text{A}$
$I_{OS}$	Input Offset Current		$V_{SENSE} = 0\text{mV}$	—	$\pm 0.02$	—	$\mu\text{A}$
G	Gain	ZXCT210	—	—	200	—	V/V
		ZXCT211	—	—	500	—	
		ZXCT212	—	—	1000	—	
		ZXCT213	—	—	50	—	
		ZXCT214	—	—	100	—	
		ZXCT215	—	—	75	—	
$E_G$	Gain Error	A and B Version, $V_{SENSE} = -5\text{mV}$ to $5\text{mV}$ , $T_A = -40^\circ\text{C}$ to $+125^\circ\text{C}$		—	$\pm 0.03\%$	$\pm 0.8\%$	—
		C Version, $V_{SENSE} = -5\text{mV}$ to $5\text{mV}$ , $T_A = -40^\circ\text{C}$ to $+125^\circ\text{C}$		—	$\pm 0.03\%$	$\pm 0.5\%$	—
—	Gain Drift vs. Temperature		$T_A = -40^\circ\text{C}$ to $+125^\circ\text{C}$	—	3	10	ppm/ $^\circ\text{C}$
—	Nonlinearity Error		$V_{SENSE} = -5\text{mV}$ to $5\text{mV}$	—	$\pm 0.01\%$	—	—
$V_{OH}$	Swing to V+ Power-Supply Rail		$R_L = 10\text{k}\Omega$ to GND, $T_A = -40^\circ\text{C}$ to $+125^\circ\text{C}$	—	$(V+) - 0.05$	$(V+) - 0.2$	V
$V_{OL}$	Swing to GND		$R_L = 10\text{k}\Omega$ to GND, $T_A = -40^\circ\text{C}$ to $+125^\circ\text{C}$	—	$(V_{GND}) + 0.005$	$(V_{GND}) + 0.05$	V
—	Maximum Capacitive Load		No Sustained Oscillation	—	1	—	nF
GBW	Bandwidth	$C_{LOAD} = 10\text{pF}$ , ZXCT210		—	14	—	kHz
		$C_{LOAD} = 10\text{pF}$ , ZXCT211		—	7	—	
		$C_{LOAD} = 10\text{pF}$ , ZXCT212		—	4	—	
		$C_{LOAD} = 10\text{pF}$ , ZXCT213		—	80	—	
		$C_{LOAD} = 10\text{pF}$ , ZXCT214		—	30	—	
		$C_{LOAD} = 10\text{pF}$ , ZXCT215		—	40	—	
SR	Slew Rate		—	—	0.4	—	V/ $\mu\text{s}$
—	Voltage Noise Density		—	—	25	—	nV/ $\sqrt{\text{Hz}}$
$V_S$	Operating Voltage Range		$T_A = -40^\circ\text{C}$ to $+125^\circ\text{C}$	2.7	—	26	V
$I_Q$	Quiescent Current		$V_{SENSE} = 0\text{mV}$	—	65	100	$\mu\text{A}$
	$I_Q$ Overtemperature		$T_A = -40^\circ\text{C}$ to $+125^\circ\text{C}$	—	—	115	$\mu\text{A}$

Note: 8. RTI stands for referred to input. For ZXCT210 and ZXCT213, the long-term stability of  $V_{OS}$  are  $100\mu\text{V}$  and  $150\mu\text{V}$  respectively which are defined as maximum  $V_{OS}$  drift during high temperature life test 1000 hours with  $T_A = +125^\circ\text{C}$ . The  $V_{OS}$  drift is not a linear function of time, and is greater initially and diminishes over time. This parameter is not in production test, but guaranteed by design.

**Typical Performance Characteristics**

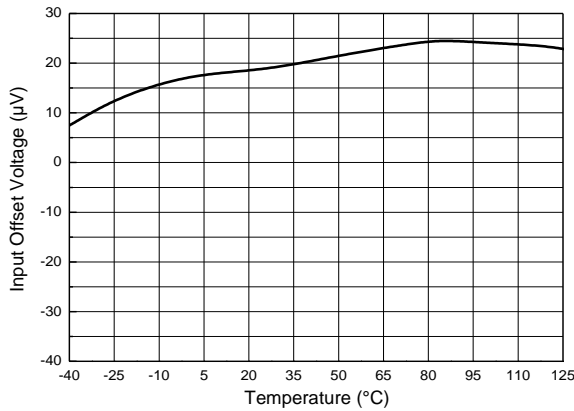

Figure 1. Offset Voltage vs. Temperature

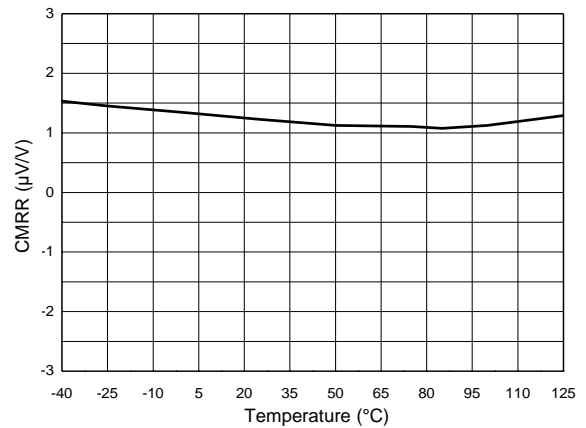

Figure 2. Common-Mode Rejection Ratio vs. Temperature

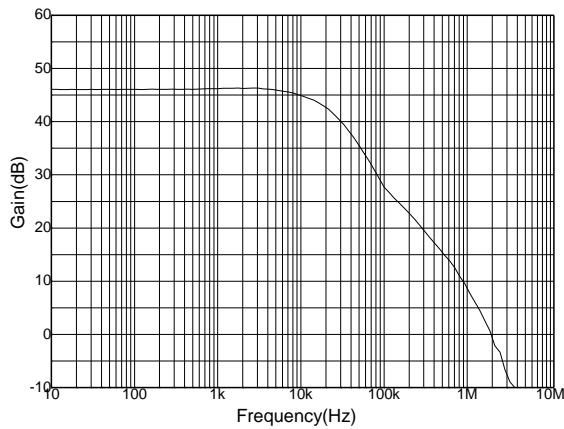

Figure 3. Gain vs. Frequency

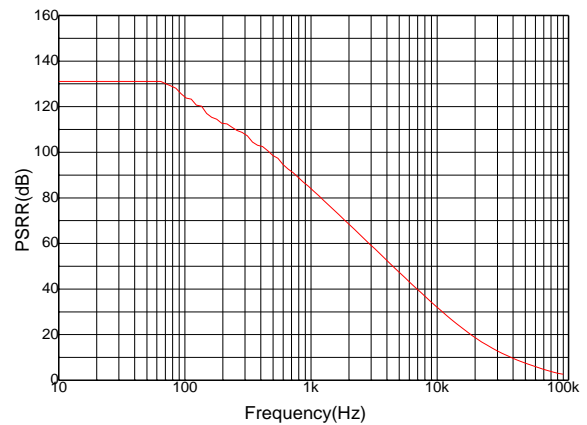

Figure 4. Power-Supply Rejection Ratio vs. Frequency

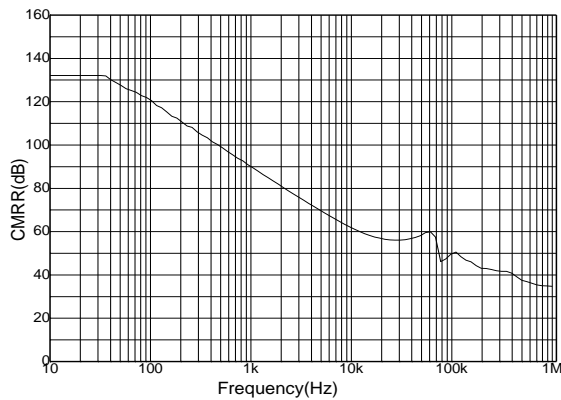

Figure 5. Common-Mode Rejection Ratio vs. Frequency

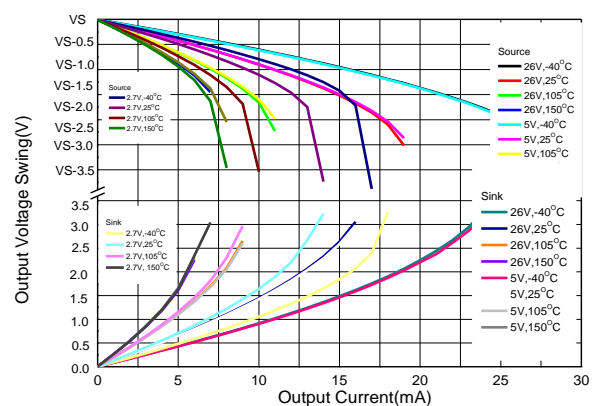

Figure 6. Output Voltage Swing vs. Output Current

**Typical Performance Characteristics** (continued)

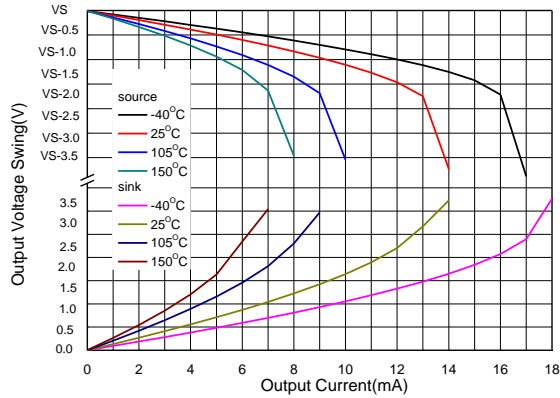

Figure 7. Output Voltage Swing vs. Output Current

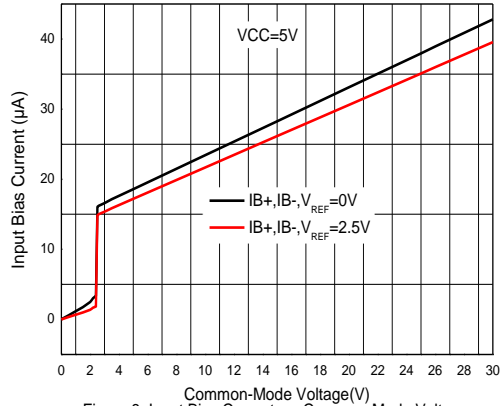

Figure 8. Input Bias Current vs. Common-Mode Voltage

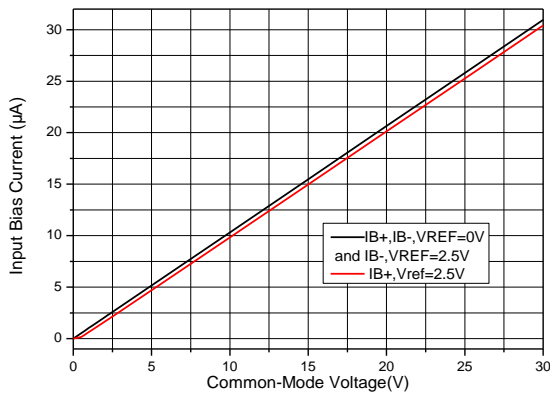

Figure 9. Input Bias Current vs. Common-Mode Voltage With Supply Voltage=0V(Shutdown)

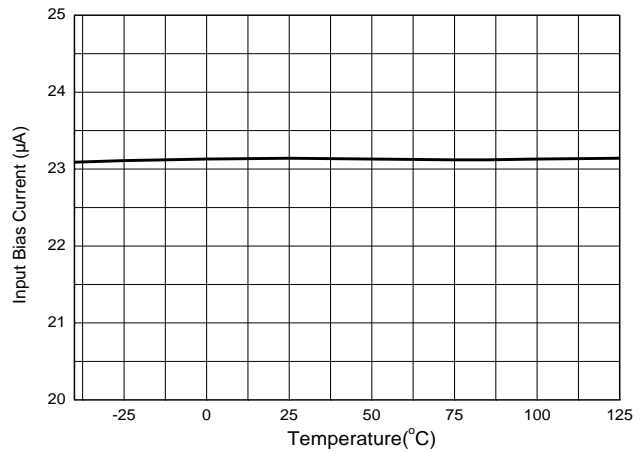

Figure 10. Input Bias Current vs. Temperature

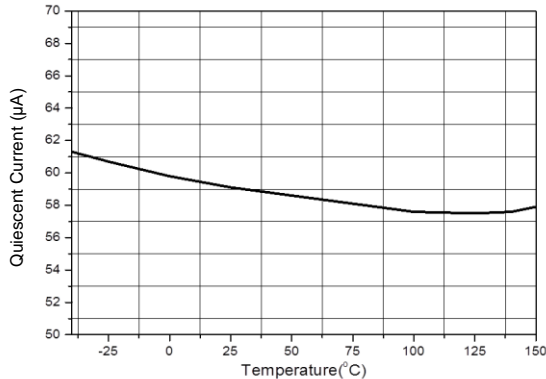

Figure 11. Quiescent Current vs. Temperature

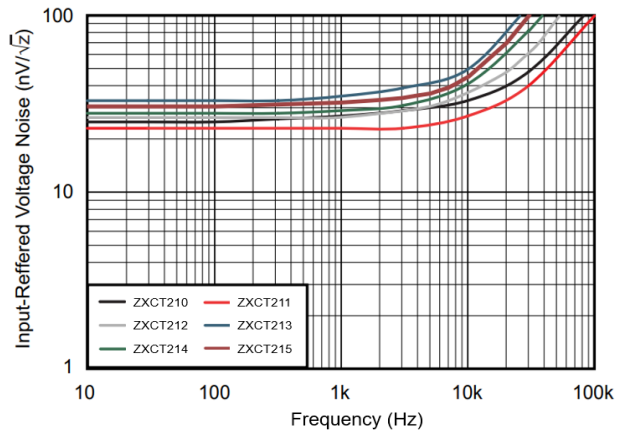

Figure 12. Input-Referred Voltage Noise vs. Frequency

**Typical Performance Characteristics** (continued)

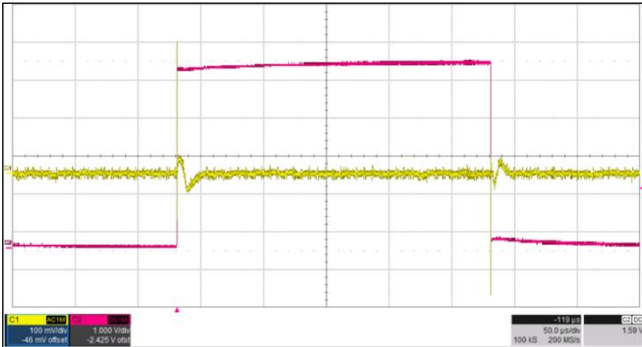

Figure 13. Common-Mode Voltage vs. Transient Response

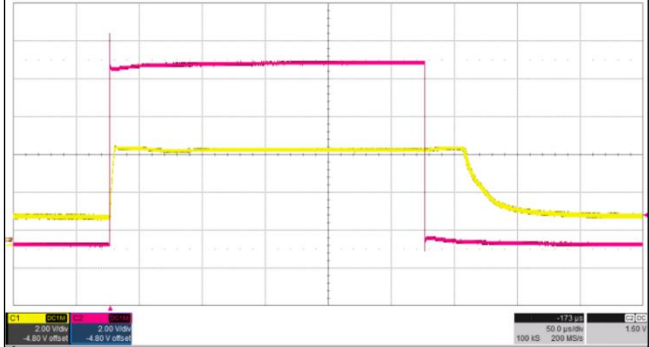

Figure 14. Noninverting Differential Input Overload

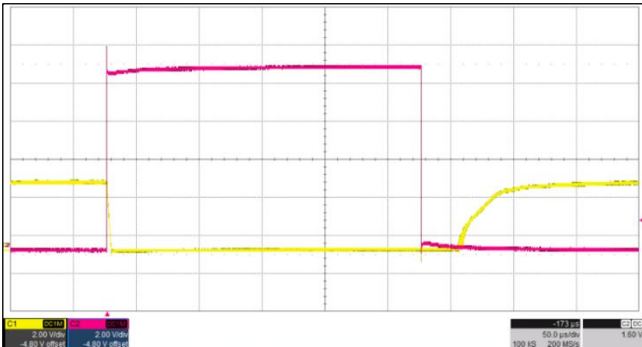

Figure 15. Inverting Differential Input Overload

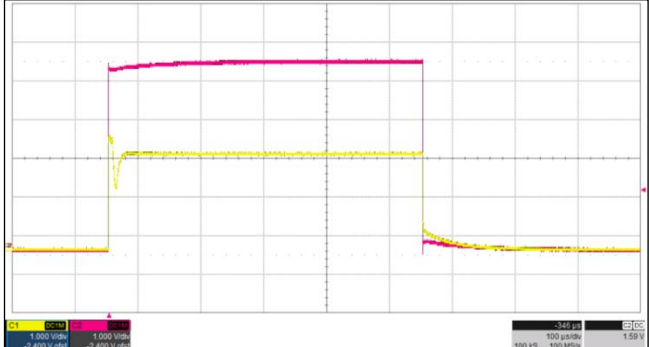

Figure 16. Startup Response

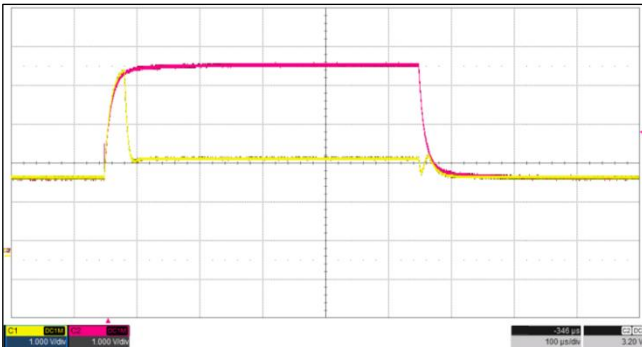

Figure 17. Brownout Recovery

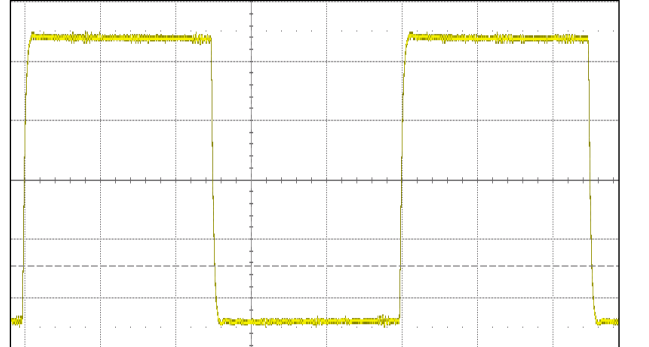

Figure 18. Output Stability with Load 2.2nF

## Application Information

The ZXCT21x series are 26V, common-mode, zero-drift, current-sensing amplifiers that can be used in both low-side and high-side configurations. These specially-designed, current-sensing amplifiers are able to accurately measure voltages developed across current-sensing resistors on common-mode voltages that far exceed the supply voltage powering the device. Current can be measured on input voltage rails as high as 26V while the device can be powered from supply voltages as low as 2.7V.

The ZXCT21x current-sense amplifiers can be configured for both low-side and high-side current sensing. Low-side sensing appears to have the advantage of being straightforward, inexpensive, and can be implemented with a simple op amp circuit. The zero-drift topology enables high-precision measurements with the low temperature drift  $0.5\mu\text{V}/^\circ\text{C}$  among full operating temperature range from  $-40^\circ\text{C}$  to  $+125^\circ\text{C}$ .

### Unidirectional Current-Sensing Circuit:

Figure 19 shows the basic connections for the ZXCT21x series to sense the unidirectional load current. The input pins, IN+ and IN-, must be connected as close as possible to the shunt resistor to minimize any resistance in series with the shunt resistor. Power-supply bypass capacitors are required for stability. It is also recommended to add decoupling capacitors to reject power-supply noise. Those capacitors would contribute in the best performance while PCB layout in consideration shall be placed as close as possible to the device pins.

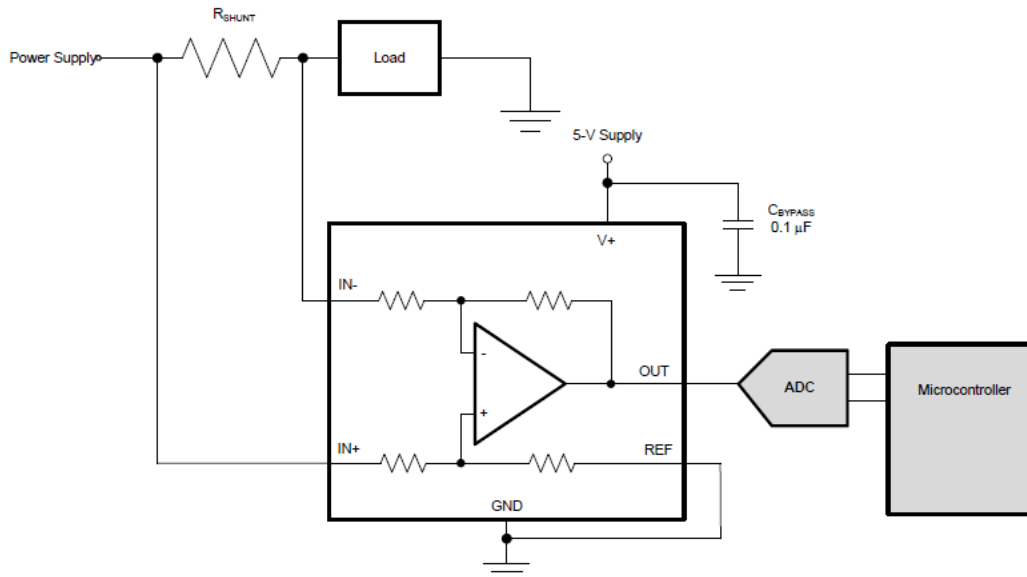

**Figure 19. Unidirectional Current Sensing Processed with an ADC**

### How to Select R<sub>SHUNT</sub>:

The zero-drift topology of the ZXCT21x offers a major advantage of the low offset characteristic enables lower full-scale drops across the shunt resistor. This results in high accuracy at a full-scale range on the order of 10mV to reduce power dissipation at the shunt resistor. While measuring load current over a wide dynamic range, lower gains of the ZXCT213, ZXCT214, or ZXCT215 are recommended to monitor a larger shunt voltage drop. For example, choose ZXCT213 (gain = 50) @  $V_+ = 3.3\text{V}$ , this can easily handle a full-scale shunt drop of 60mV to convert  $\text{OUT} = 3.0\text{V}$ . And then MCU can read out ADC for a real-time current monitoring.

### Bidirectional Current-Sensing Circuit:

Figure 20 shows an alternative connection in applications for the bidirectional current sensing. What is different from Figure 19 is the configuration of REF pin. In bidirectional current sensing, the current measurements are taken when current is flowing in both directions. For example, BMS (battery management system), the current is measured when the battery is being charged or discharged.

Bidirectional operation requires the output to swing both positive and negative around a bias voltage applied to the REF pin. The voltage applied to the REF pin depends on the application. However, most often it is biased to either half of the supply voltage or to half the value of the measurement system reference. Take care the REF pin must always be connected to a low impedance circuit and to avoid any voltage that exceeds its absolute maximum rating.



**Application Information** (continued)

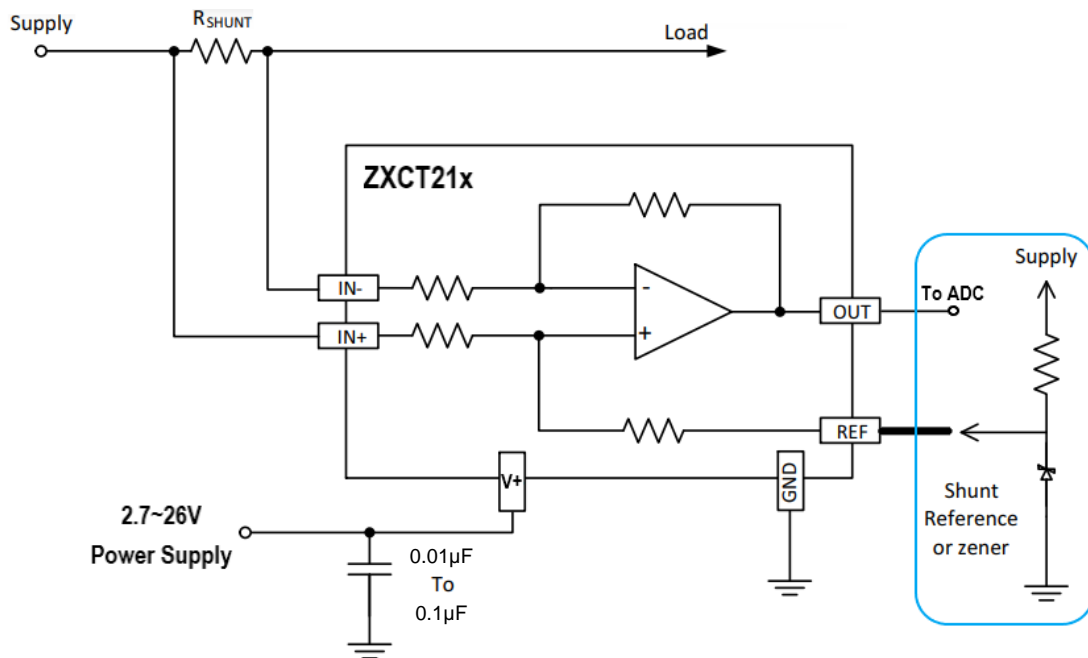

Figure 20. Bidirectional Current Sensing with an External Voltage Reference Circuit

**Input Filtering**

Input filtering may be needed to limit the bandwidth of signals or to add protection against transients that may be generated as the result of shunt inductance. Input filter resistors associates resistance mismatch between them can adversely affect gain, CMRR, and VOS. The effect on VOS is partly due to input bias currents as well. As a result, the value of the input resistors should be limited to 10Ω or less. Ideally, select the capacitor to exactly match the time constant of the shunt resistor and its inductance. Figure 21 shows a filter placed at the inputs pins in some applications, where the current being measured may be inherently noisy.

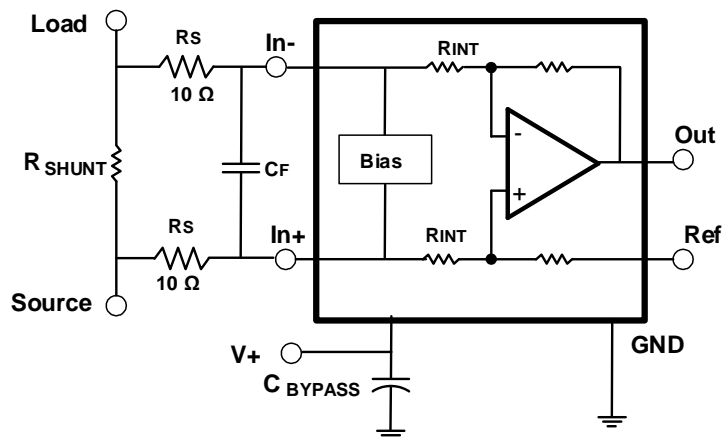

Figure 21.  $R_s$  ( $< 10\Omega$ ) and  $C_f$  to Compensate for Shunt Inductance on Shunts Less than 1mΩ or in Noisy Applications.

## Application Information (continued)

As a consideration to mitigate the impact of shunt inductance in a high-current, high-transient environment, the RC time constant of the added  $R_S$  and  $C_F$  should be greater than the time constant implied by the inductance and resistance implied by  $R_{SHUNT}$ .

$$2 \cdot R_S \cdot C_F \geq \frac{L_{SHUNT}}{R_{SHUNT}}$$

Due to additional current used in the bias circuit the voltage between the IN- and IN+ pins will differ from voltage across the sense resistor. This will appear as a gain error at the output. These internal bias currents from the inputs are not equal in magnitude and change depending on common-mode conditions. This is the motivation of keeping the added resistor below 10Ω. The chart below has the equations for calculating the gain errors based on adding well-matched source resistors. The equations include a provision for the additional 20μA current used by the bias circuit block that is depicted as bias in Figure 19.

Part Number	Gain	R <sub>INT</sub> R3 and R4	Gain Error Factor Equations	Gain Error % *
				R <sub>S</sub> = 5Ω
ZXCT210	200	5kΩ	$\frac{1000}{R_S + 1000}$	0.4975%
ZXCT211	500	2kΩ	$\frac{10000}{13 \cdot R_S + 10000}$	0.6458%
ZXCT212	1000	1kΩ	$\frac{5000}{9 \cdot R_S + 5000}$	0.8919%
ZXCT213	50	20kΩ	$\frac{20000}{17 \cdot R_S + 20000}$	0.4232%
ZXCT214	100	10kΩ	$\frac{10000}{9 \cdot R_S + 10000}$	0.4479%
ZXCT215	75	13.3kΩ	$\frac{8000}{7 \cdot R_S + 8000}$	0.4356%

\*The percentages shown should be rounded to 2 significant figures. The excess can be used to check calculations. This is for a typical semiconductor process.

$$\text{Gain Error (\%)} = 100 \cdot (1 - \text{Gain Error Factor})$$

Where:

R<sub>INT</sub> is the internal resistors R3 and R4 used to set the gain and differs per device type.

R<sub>S</sub> is the added input resistors.

## Ordering Information

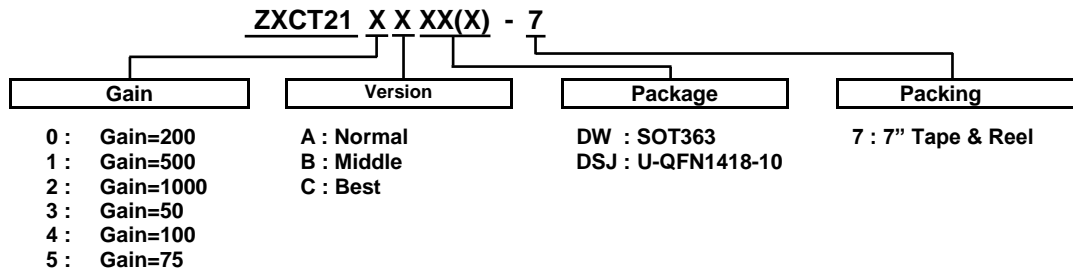

Part Number	Package Code	Package	Packing	
			Qty.	Carrier
ZXCT210ADW-7	DW	SOT363	3000	7" Tape and Reel
ZXCT210BDW-7	DW	SOT363	3000	7" Tape and Reel
ZXCT210CDW-7	DW	SOT363	3000	7" Tape and Reel
ZXCT210ADSJ-7	DSJ	U-QFN1418-10	3000	7" Tape and Reel
ZXCT210BDSJ-7	DSJ	U-QFN1418-10	3000	7" Tape and Reel
ZXCT210CDSJ-7	DSJ	U-QFN1418-10	3000	7" Tape and Reel
ZXCT211ADW-7	DW	SOT363	3000	7" Tape and Reel
ZXCT211BDW-7	DW	SOT363	3000	7" Tape and Reel
ZXCT211CDW-7	DW	SOT363	3000	7" Tape and Reel
ZXCT211ADSJ-7	DSJ	U-QFN1418-10	3000	7" Tape and Reel
ZXCT211BDSJ-7	DSJ	U-QFN1418-10	3000	7" Tape and Reel
ZXCT211CDSJ-7	DSJ	U-QFN1418-10	3000	7" Tape and Reel
ZXCT212ADW-7	DW	SOT363	3000	7" Tape and Reel
ZXCT212BDW-7	DW	SOT363	3000	7" Tape and Reel
ZXCT212CDW-7	DW	SOT363	3000	7" Tape and Reel
ZXCT212ADSJ-7	DSJ	U-QFN1418-10	3000	7" Tape and Reel
ZXCT212BDSJ-7	DSJ	U-QFN1418-10	3000	7" Tape and Reel
ZXCT212CDSJ-7	DSJ	U-QFN1418-10	3000	7" Tape and Reel
ZXCT213ADW-7	DW	SOT363	3000	7" Tape and Reel
ZXCT213BDW-7	DW	SOT363	3000	7" Tape and Reel
ZXCT213CDW-7	DW	SOT363	3000	7" Tape and Reel
ZXCT213ADSJ-7	DSJ	U-QFN1418-10	3000	7" Tape and Reel
ZXCT213BDSJ-7	DSJ	U-QFN1418-10	3000	7" Tape and Reel
ZXCT213CDSJ-7	DSJ	U-QFN1418-10	3000	7" Tape and Reel
ZXCT214ADW-7	DW	SOT363	3000	7" Tape and Reel
ZXCT214BDW-7	DW	SOT363	3000	7" Tape and Reel
ZXCT214CDW-7	DW	SOT363	3000	7" Tape and Reel
ZXCT214ADSJ-7	DSJ	U-QFN1418-10	3000	7" Tape and Reel
ZXCT214BDSJ-7	DSJ	U-QFN1418-10	3000	7" Tape and Reel
ZXCT214CDSJ-7	DSJ	U-QFN1418-10	3000	7" Tape and Reel
ZXCT215ADW-7	DW	SOT363	3000	7" Tape and Reel
ZXCT215BDW-7	DW	SOT363	3000	7" Tape and Reel
ZXCT215CDW-7	DW	SOT363	3000	7" Tape and Reel
ZXCT215ADSJ-7	DSJ	U-QFN1418-10	3000	7" Tape and Reel
ZXCT215BDSJ-7	DSJ	U-QFN1418-10	3000	7" Tape and Reel
ZXCT215CDSJ-7	DSJ	U-QFN1418-10	3000	7" Tape and Reel

## Marking Information

SOT363

(Top View)

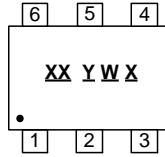

**XX** : Identification Code  
**Y** : Year 0~9  
**W** : Week : A~Z : 1~26 week;  
           a~z : 27~52 week; z represents  
           52 and 53 week  
**X** : Internal Code

Part Number	Package	Identification Code
ZXCT210ADW-7	SOT363	YC
ZXCT210BDW-7	SOT363	YD
ZXCT210CDW-7	SOT363	YE
ZXCT211ADW-7	SOT363	YF
ZXCT211BDW-7	SOT363	YG
ZXCT211CDW-7	SOT363	YH
ZXCT212ADW-7	SOT363	YJ
ZXCT212BDW-7	SOT363	YK
ZXCT212CDW-7	SOT363	YM
ZXCT213ADW-7	SOT363	YN
ZXCT213BDW-7	SOT363	YP
ZXCT213CDW-7	SOT363	YR
ZXCT214ADW-7	SOT363	YS
ZXCT214BDW-7	SOT363	YT
ZXCT214CDW-7	SOT363	YU
ZXCT215ADW-7	SOT363	YV
ZXCT215BDW-7	SOT363	YW
ZXCT215CDW-7	SOT363	YX

U-QFN1418-10

(Top View)

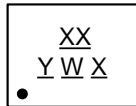

**XX** : Identification Code  
**Y** : Year : 0~9  
**W** : Week : A~Z : 1~26 week;  
           a~z : 27~52 week; z represents  
           52 and 53 week  
**X** : Internal Code

Part Number	Package	Identification Code
ZXCT210ADSJ-7	U-QFN1418-10	V2
ZXCT210BDSJ-7	U-QFN1418-10	V3
ZXCT210CDSJ-7	U-QFN1418-10	V4
ZXCT211ADSJ-7	U-QFN1418-10	V5
ZXCT211BDSJ-7	U-QFN1418-10	V6
ZXCT211CDSJ-7	U-QFN1418-10	V7
ZXCT212ADSJ-7	U-QFN1418-10	V8
ZXCT212BDSJ-7	U-QFN1418-10	V9
ZXCT212CDSJ-7	U-QFN1418-10	VA
ZXCT213ADSJ-7	U-QFN1418-10	VB
ZXCT213BDSJ-7	U-QFN1418-10	VC
ZXCT213CDSJ-7	U-QFN1418-10	VD
ZXCT214ADSJ-7	U-QFN1418-10	VE
ZXCT214BDSJ-7	U-QFN1418-10	VF
ZXCT214CDSJ-7	U-QFN1418-10	VG
ZXCT215ADSJ-7	U-QFN1418-10	VH
ZXCT215BDSJ-7	U-QFN1418-10	VJ
ZXCT215CDSJ-7	U-QFN1418-10	VK

**Package Outline Dimensions**

Please see <http://www.diodes.com/package-outlines.html> for the latest version.

**SOT363**

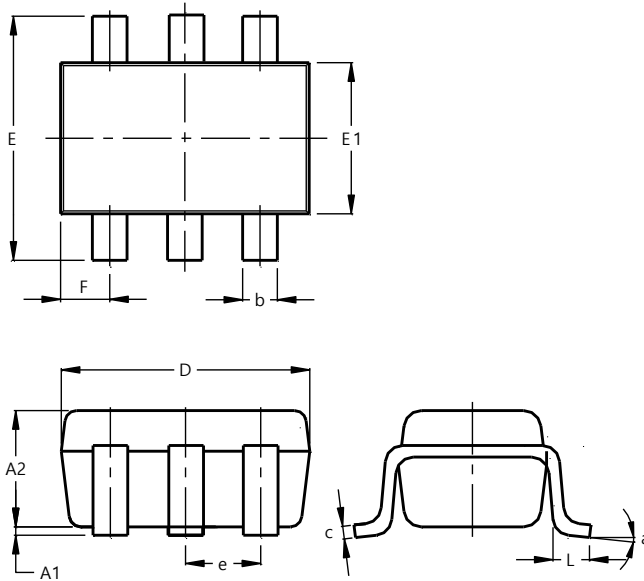

SOT363			
Dim	Min	Max	Typ
A1	0.00	0.10	0.05
A2	0.90	1.00	0.95
b	0.10	0.30	0.25
c	0.10	0.22	0.11
D	1.80	2.20	2.15
E	2.00	2.20	2.10
E1	1.15	1.35	1.30
e	0.650 BSC		
F	0.40	0.45	0.425
L	0.25	0.40	0.30
a	0°	8°	--
<b>All Dimensions in mm</b>			

**U-QFN1418-10**

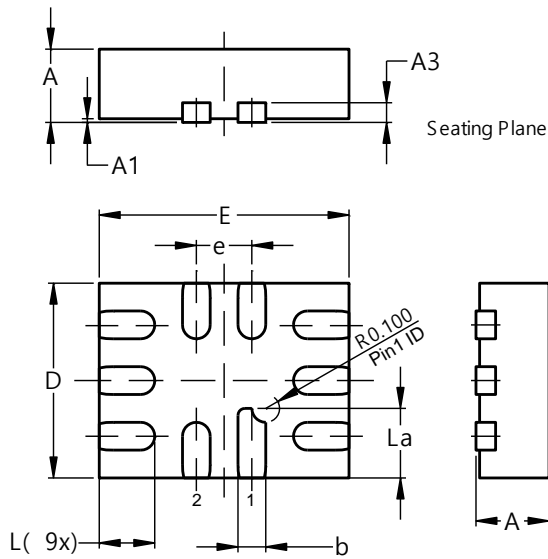

U-QFN1418-10			
Dim	Min	Max	Typ
A	0.45	0.55	0.50
A1	0.00	0.05	0.02
A3	--	--	0.13
b	0.15	0.25	0.20
D	1.35	1.45	1.40
E	1.75	1.85	1.80
e	--	--	0.40
L	0.35	0.45	0.40
L <sub>a</sub>	0.45	0.55	0.50
<b>All Dimensions in mm</b>			

**Suggested Pad Layout**

Please see <http://www.diodes.com/package-outlines.html> for the latest version.

**SOT363**

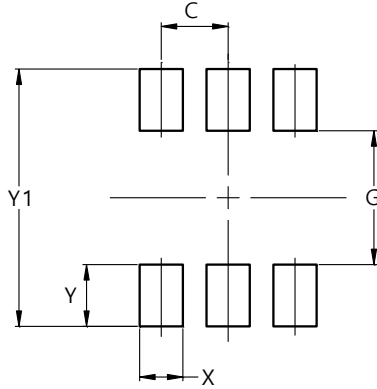

Dimensions	Value (in mm)
C	0.650
G	1.300
X	0.420
Y	0.600
Y1	2.500

**U-QFN1418-10**

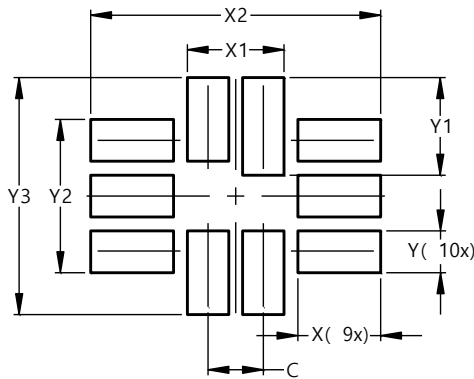

Dimensions	Value (in mm)
C	0.400
X	0.600
X1	0.700
X2	2.100
Y	0.300
Y1	0.700
Y2	1.100
Y3	1.700

**Mechanical Data**

**SOT363**

- Moisture Sensitivity: Level 1 per J-STD-020
- Terminals: Finish – Matte Tin Plated Leads, Solderable per MIL-STD-202, Method 208 (e3)
- Weight: 0.006 grams (Approximate)
- Max Soldering Temperature +260°C for 30 secs as per JEDEC J-STD-020

**U-QFN1418-10**

- Moisture Sensitivity: Level 1 per J-STD-020
- Terminals: NiPdAu over Copper Leads, Solderable per MIL-STD-202, Method 208 (e4)
- Weight: 0.004 grams (Approximate)
- Max Soldering Temperature +260°C for 30 secs as per JEDEC J-STD-020