

Features

- Combination of 120V NPN Darlington Transistor and 120V Rectifier Diode
- High Current Gain: $h_{FE} = 2000\text{min}$ @ $V_{CE} = 2V, I_C = 1A$
- **Totally Lead-Free & Fully RoHS Compliant (Notes 1 & 2)**
- **Halogen and Antimony Free. "Green" Device (Note 3)**

Application

- Printer Head Driver

Mechanical Data

- Case: V-DFN3030-8
- UL Flammability Rating 94V-0
- Case Material: Molded Plastic. "Green" Molding Compound. Moisture Sensitivity: Level 1 per J-STD-020
- Terminals: Finish — NiPdAu over Copper Leadframe. Solderable per MIL-STD-202, Method 208
- Weight: 0.02 grams (Approximate)

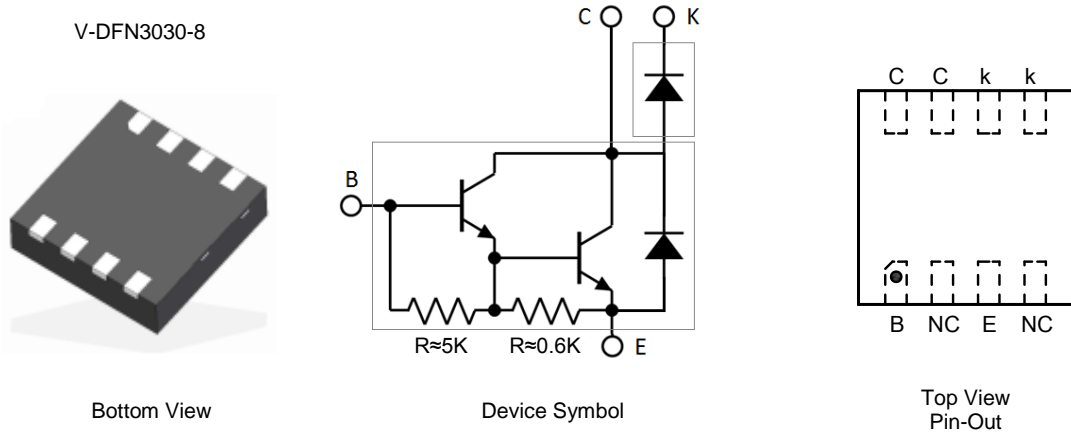

Ordering Information (Note 4)

Product	Marking	Reel Size (inches)	Tape Width (mm)	Quantity per Reel
ZXPD4000DH-7	1T9	7	8	3,000

- Notes:
1. No purposely added lead. Fully EU Directive 2002/95/EC (RoHS), 2011/65/EU (RoHS 2) & 2015/863/EU (RoHS 3) compliant.
 2. See <https://www.diodes.com/quality/lead-free/> for more information about Diodes Incorporated's definitions of Halogen- and Antimony-free, "Green" and Lead-free.
 3. Halogen- and Antimony-free "Green" products are defined as those which contain <900ppm bromine, <900ppm chlorine (<1500ppm total Br + Cl) and <1000ppm antimony compounds.
 4. For packaging details, go to our website at <https://www.diodes.com/design/support/packaging/diodes-packaging/>.

Marking Information

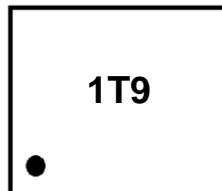

1T9 = Product Type Marking Code

BJT Absolute Maximum Ratings (@T_A = +25°C, unless otherwise specified.)

Characteristic	Symbol	Value	Unit
Collector-Base Voltage	V _{CB0}	120	V
Collector-Emitter Voltage	V _{CEO}	120	V
Emitter-Base Voltage	V _{EBO}	8	V
Continuous Collector Current	I _C	2	A
Peak Collector Current	I _{CP}	3	A
Base Current	I _B	0.5	A

Diode Absolute Maximum Ratings (@T_A = +25°C, unless otherwise specified.)

Characteristic	Symbol	Value	Unit
Repetitive Peak Reverse Voltage	V _R RM	120	V
Average Current	I _{F(AV)}	1	A
Non-Repetitive Peak Forward Current (Surge Current), 1 Cycle (50Hz)	I _{FSM}	15	A

Thermal Characteristics (@T_A = +25°C, unless otherwise specified.)

Characteristic	Symbol	Value	Unit
Power Dissipation (Note 5)	P _D	0.9	W
Power Dissipation (Note 6)	P _D	0.72	W
Thermal Resistance, Junction to Ambient (Note 5)	R _{θJA}	139	°C/W
Thermal Resistance, Junction to Ambient (Note 6)	R _{θJA}	172	°C/W
Operating and Storage Temperature Range	T _J , T _{STG}	-55 to +150	°C

ESD Ratings (Note 7)

Characteristic	Symbol	Value	Unit	JEDEC Class
Electrostatic Discharge – Human Body Model	ESD HBM	4,000	V	3A
Electrostatic Discharge – Machine Model	ESD MM	400	V	C

- Notes:
5. For a device surface mounted on 25mm X 25mm X 1.6mm FR-4 PCB with high coverage of single sided 1 oz copper, in still air conditions.
 6. Same as Note 5, except the device is mounted on minimum recommended pad layout.
 7. Refer to JEDEC specification JESD22-A114 and JESD22-A115.

BJT Electrical Characteristics (@T_A = +25°C, unless otherwise specified.)

Characteristic	Symbol	Min	Typ	Max	Unit	Test Condition
Collector Cutoff Current	I _{CBO}	-	-	10	μA	V _{CB} = 120V, I _E = 0
Emitter Cutoff Current	I _{EBO}	1	-	2.67	mA	V _{EB} = 8V, I _C = 0
Collector-Emitter Breakdown Voltage	BV _{CEO}	120	-	-	V	I _C = 10mA, I _B = 0
DC Current Gain	h _{FE}	2000	-	9000	-	V _{CE} = 2V, I _C = 1A
Collector-Emitter Saturation Voltage	V _{CE(sat)}	-	-	1.5	V	I _C = 1A, I _B = 1mA
Base-Emitter Saturation Voltage	V _{BE(sat)}	-	-	2	V	I _C = 1A, I _B = 1mA
Output Capacitance	C _{obo}	-	12	-	pF	V _{CB} = 10V, I _E = 0, f = 1MHz
Delay Time	t _D	-	0.34	-	μs	V _{CC} = 30V, R _L = 30Ω, I _{B1} = -I _{B2} = 1mA
Rise Time	t _R	-	1.8	-	μs	
Storage time	t _{STG}	-	0.2	-	μs	
Fall Time	t _F	-	0.15	-	μs	

Diode Electrical Characteristics (@T_A = +25°C, unless otherwise specified.)

Characteristic	Symbol	Min	Typ	Max	Unit	Test Condition
Peak Forward Voltage	V _{FM}	-	-	0.98	V	I _{FM} = 1 A
Reverse Leakage Current	I _R	-	-	10	μA	V _R = 120V
Reverse Recovery Time	t _{RR}	-	300	450	ns	I _F = 1A, di/dt = -20A/μs
Forward Recovery Time	t _{FR}	-	150	300	ns	I _F = 1A

BJT Typical Electrical Characteristics (@ $T_A = +25^\circ\text{C}$, unless otherwise specified.)

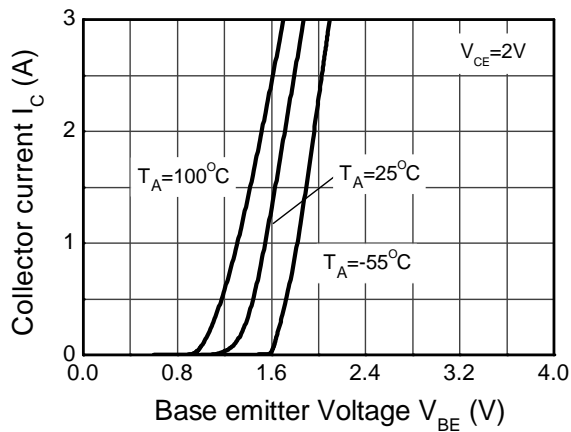
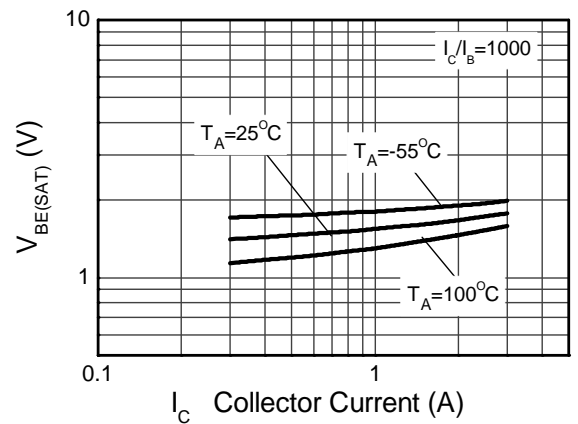
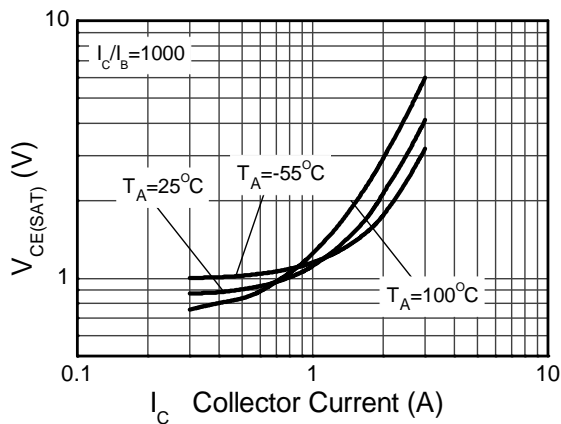
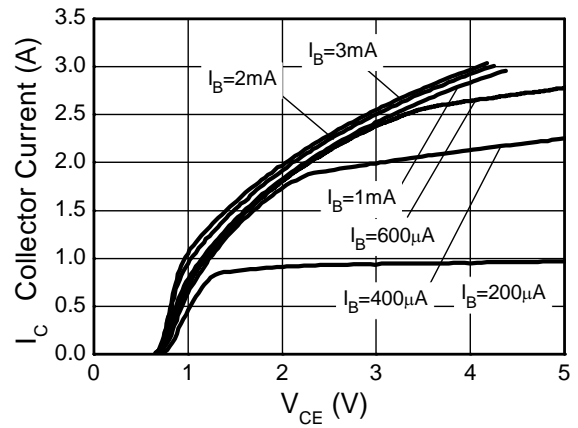
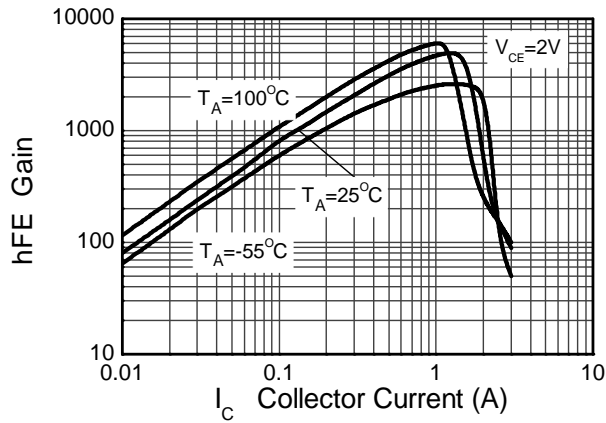

BJT Typical Electrical Characteristics (@ $T_A = +25^\circ\text{C}$, unless otherwise specified.)

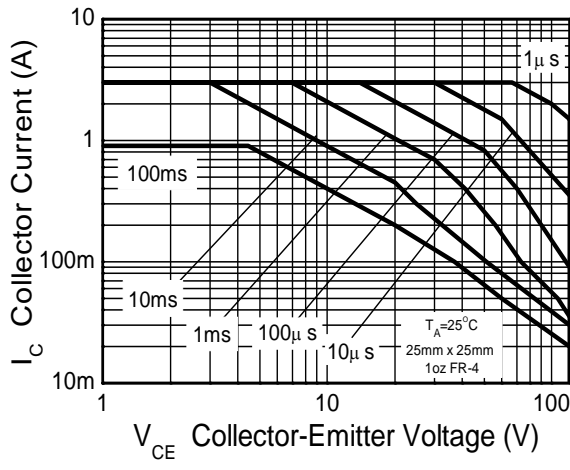

Forward Bias Safe operating Area

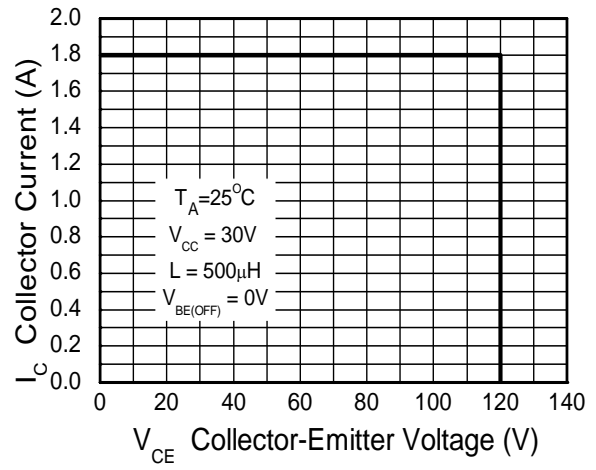

Reverse Bias Safe operating Area

Package Outline Dimensions

Please see <http://www.diodes.com/package-outlines.html> for the latest version.

V-DFN3030-8

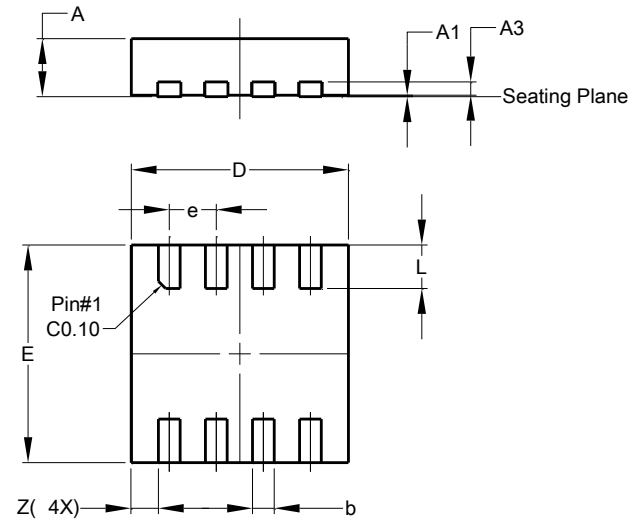

V-DFN3030-8			
Dim	Min	Max	Typ
A	0.75	0.85	0.80
A1	0.00	0.05	0.02
A3	-	-	0.203
b	0.25	0.35	0.30
D	2.95	3.05	3.00
E	2.95	3.05	3.00
e	-	-	0.65
L	0.55	0.65	0.60
Z	-	-	0.375
All Dimensions in mm			

Suggested Pad Layout

Please see <http://www.diodes.com/package-outlines.html> for the latest version.

V-DFN3030-8

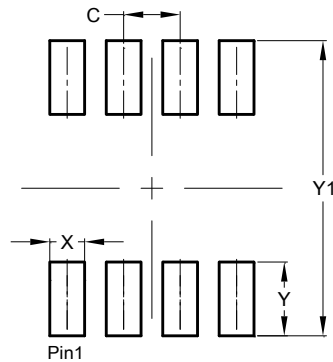

Dimensions	Value (in mm)
C	0.650
X	0.400
Y	0.850
Y1	3.400