

## AC/DC Digital Power Controller for Single-Stage High Power Factor Dimmable LED Drivers

### 1 Description

The iW3681-20 is a single-stage, high-performance AC/DC off-line power supply controller for dimmable LED luminaires. It applies advanced digital control technology to detect the dimmer type, enabling it to provide dynamic impedance to interface with the dimmer and to control the LED brightness at the same time.

With advanced dimmer detection technology, the iW3681-20 can operate with most wall dimmers including leading-edge dimmers (R-type or R-L type), trailing-edge dimmers (R-C type), and smart dimmers. In addition, the iW3681-20's cycle-by-cycle waveform analysis technology allows for fast dimmer transient response.

In no-dimmer mode, the iW3681-20 operates the main power converter that delivers current to the LED load in quasi-resonant mode to provide high power efficiency and low electro-magnetic interference (EMI). The commonly utilized converter topologies for iW3681-20 are buck-boost and flyback.

The iW3681-20 uses patented **PrimAccurate**<sup>™</sup> primary-side sensing technology to achieve excellent LED current regulation under different AC line and LED load voltages, without using a secondary-side feedback circuit and thus eliminating the need for an opto-coupler.

The iW3681-20 minimizes the external components count by simplifying the EMI filter with Dialog's **EZ-EMI**<sup>®</sup> technology, and by integrating current sink, switching, and  $V_{CC}$  charging circuit. Additionally, the iW3681-20 does not require an auxiliary winding, which eliminates the need for a custom inductor. The digital control loop of the iW3681-20 maintains stability over all operating conditions without the need for loop compensation components.

The iW3681-20 maintains high performance wide-range dimming and achieves excellent dimmer compatibility with a simple application circuit.

### 2 Features

- Isolated/non-isolated off-line 120V<sub>AC</sub>/230V<sub>AC</sub> LED driver up to 25W (Note 1)
- Wide line frequency range (from 45Hz to 66Hz)
- Meets IEC61000-3-2 current harmonic requirement
- Excellent dimmer compatibility
  - » Leading-edge dimmer
  - » Trailing-edge dimmer
  - » Digital smart dimmer
- Wide dimming range of 1% to 100%
- Intelligent digital control integrates current sink and  $V_{CC}$  maintenance function into power switching circuit
- Advanced IC power management and voltage sensing enables the use of off-the-shelf inductor
- Resonant control to achieve high efficiency (typical >85% without dimmer)
- Excellent AC line distortion immunity ensures quality of product under real-life circumstances
- Over-temperature LED current foldback and shutdown
- Tight LED current regulation ( $\pm 5\%$ )
- Fast start-up (< 0.5s without dimmer)
- Multiple protection features that include:
  - » LED open-circuit and short-circuit protection
  - » Current sensing resistor open circuit and short-circuit protection
  - » Over-current protection

### 3 Applications

- Dimmable LED retrofit lamps up to 25W (Note 1)
- Dimmable LED luminaires up to 25W (Note 1)

AC/DC Digital Power Controller for  
Single-Stage High Power Factor Dimmable LED Drivers

Company Confidential

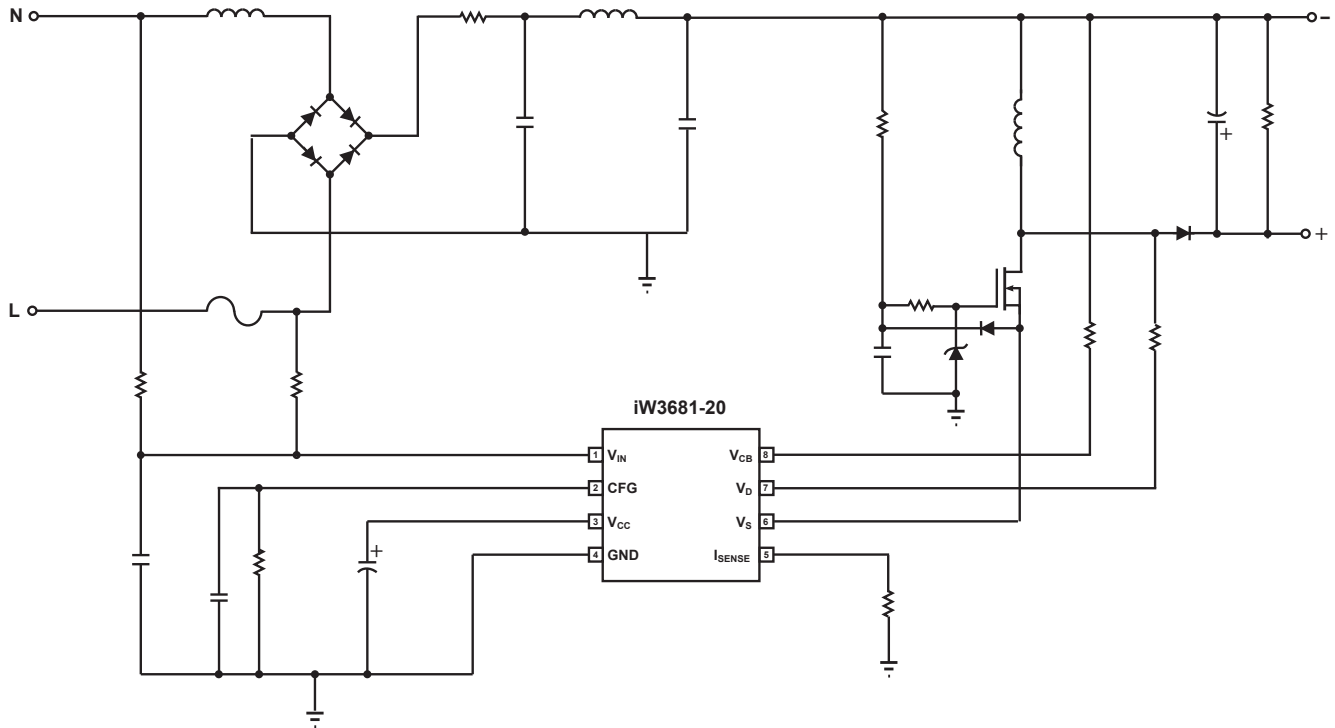

Figure 3.1 : iW3681-20 Typical Application Circuit

Note 1 : For output power above 12W designs, care should be taken to verify the thermal and reliability constrains on the IC. IC temperature below 120°C is recommended for proper IC operation.

## AC/DC Digital Power Controller for Single-Stage High Power Factor Dimmable LED Drivers

Company Confidential

### 4 Pinout Description

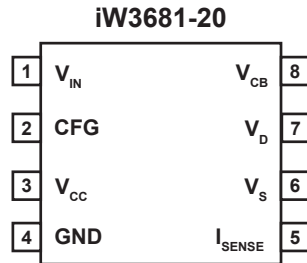

Figure 4.1 : 8-Lead SOIC-8 Package

Pin Number	Pin Name	Type	Pin Description
1	$V_{IN}$	Analog Input	Rectified AC line voltage input.
2	CFG	Analog Input	OTP threshold and dimmer mode configuration on start-up.
3	$V_{CC}$	Power	Power supply for control logic.
4	GND	Ground	Ground.
5	$I_{SENSE}$	Analog Input	Current sense.
6	$V_S$	Analog Input	Source voltage of MOSFET.
7	$V_D$	Analog Input	Drain voltage of MOSFET.
8	$V_{CB}$	Analog Input	Input capacitor voltage after EMI filter.

## AC/DC Digital Power Controller for Single-Stage High Power Factor Dimmable LED Drivers

Company Confidential

### 5 Absolute Maximum Ratings

Absolute maximum ratings are the parameter values or ranges which can cause permanent damage if exceeded.

Parameter	Symbol	Value	Unit
DC supply voltage range (pin 3)	$V_{CC}$	-0.3 to 6	V
$V_{IN}$ input (pin 1)		-0.3 to 6	V
CFG input (pin 2)		-0.3 to 6	V
$I_{SENSE}$ input (pin 5)		-0.3 to 6	V
$V_S$ input (pin 6)		-0.3 to 24	V
$V_D$ input voltage (pin 7)		-0.3 to 6	V
$V_{CB}$ input voltage (pin 8)		-0.3 to 6	V
$V_D$ input current (pin 7)		750	$\mu A$
$V_{CB}$ input current (pin 8)		750	$\mu A$
Power dissipation at $T_A \leq 25^\circ C$		900	mW
Maximum junction temperature	$T_{JMAX}$	150	$^\circ C$
Operating junction temperature	$T_{JOPT}$	-40 to 150	$^\circ C$
Storage temperature	$T_{STG}$	-65 to 150	$^\circ C$
Thermal resistance junction-to-PCB [gnd lead]	$\Psi_{JB}$	75	$^\circ C/W$
ESD rating per JEDEC JESD22-A114		$\pm 2,000$	V
Latch-up test per JESD78A		$\pm 100$	mA

## AC/DC Digital Power Controller for Single-Stage High Power Factor Dimmable LED Drivers

Company Confidential

### 6 Electrical Characteristics

 $V_{CC} = 5V$ ,  $-40^{\circ}C \leq T_A \leq 85^{\circ}C$ , unless otherwise specified (Note 1)

Parameter	Symbol	Test Conditions	Min	Typ	Max	Unit
<b>V<sub>IN</sub> SECTION</b>						
Start-up voltage threshold (Note 2 & 3)	$V_{IN(ST)}$	$T_A = 25^{\circ}C$ , pulse width $\geq 500\mu s$		0.4		V
$V_{IN}$ scaling resistance (Note 4)	$Z_{VIN}$	After start-up, $T_A = 25^{\circ}C$	2.425	2.5	2.575	k $\Omega$
$V_{IN}$ sampling range (Note 2 & 3)	$V_{IN}$	After start-up	0		1.8	V
<b>V<sub>D</sub>/V<sub>CB</sub> SECTION</b>						
Output over-voltage protection (OVP) threshold (Note 3)	$V_{SENSE(OVP)}$	$T_A = 25^{\circ}C$ , negative edge		1.95		V
Output nominal threshold (Note 3)	$V_{SENSE(NOM)}$	$T_A = 25^{\circ}C$ , negative edge		1.5		V
Output under-voltage protection (UVP) threshold (Note 3)	$V_{SENSE(UVP)}$	$T_A = 25^{\circ}C$ , negative edge		0.15		V
<b>Source Switch SECTION</b>						
Internal switching MOSFET ON-resistance	$R_{DS(ON)}$	$T_A = 25^{\circ}C$		0.25	0.5	$\Omega$
Maximum switching frequency (Note 5)	$f_{SW(MAX)}$			200		kHz
Sinking current at quarter range (Note 6)	$I_{PK(CS\_QUARTER)}$	$V_S = 12V$ , $T_A = 25^{\circ}C$		67		mA
<b>V<sub>CC</sub> SECTION</b>						
Operating voltage	$V_{CC}$	$T_A = 25^{\circ}C$		5	5.6	V
Start-up threshold	$V_{CC(ST)}$			5		V
Under-voltage lockout threshold	$V_{CC(UVL)}$			4		V
Operating current	$I_{CC}$			2.5		mA
<b>I<sub>SENSE</sub> SECTION</b>						
$I_{SENSE}$ short protection reference	$V_{RSENSE}$			0.16		V
Over-current limit threshold	$V_{OCP}$			1.4		V

## AC/DC Digital Power Controller for Single-Stage High Power Factor Dimmable LED Drivers

Company Confidential

### 6.0 Electrical Characteristics (cont.)

 $V_{CC} = 5V$ ,  $-40^{\circ}C \leq T_A \leq 85^{\circ}C$ , unless otherwise specified (Note 1)

Parameter	Symbol	Test Conditions	Min	Typ	Max	Unit
<b>Configuration SECTION</b>						
CFG pin configuration current	$I_{CFG}$		95	100	105	$\mu A$
<b>Temperature Derating and Over-Temperature Protection SECTION</b>						
Shutdown threshold (Note 3)	$T_{OTP(START)}$			150		$^{\circ}C$

#### Notes:

- Note 1. Adjust  $V_{CC}$  above the start-up threshold before setting at 5V.
- Note 2. Refer to the voltage level at the  $V_{IN\_A}$  point in Figure 8.1. The typical impedance between the  $V_{IN}$  pin and  $V_{IN\_A}$  point is  $500\Omega$ .
- Note 3. These parameters are not 100% tested. They are guaranteed by design.
- Note 4. Refer to  $Z_{VIN}$  in Figure 8.1.
- Note 5. Operating frequency varies based on the line and load conditions. See the Theory of Operation section (Section 9.0) for more details.
- Note 6. The peak sinking current is quadruple the sinking current at quarter range.

AC/DC Digital Power Controller for Single-Stage High Power Factor Dimmable LED Drivers

7 Typical Performance Characteristics

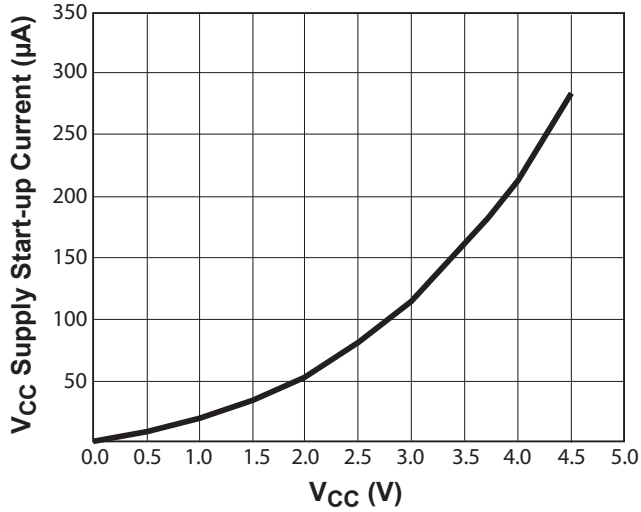

Figure 7.1 : V<sub>CC</sub> vs. V<sub>CC</sub> Supply Start-up Current

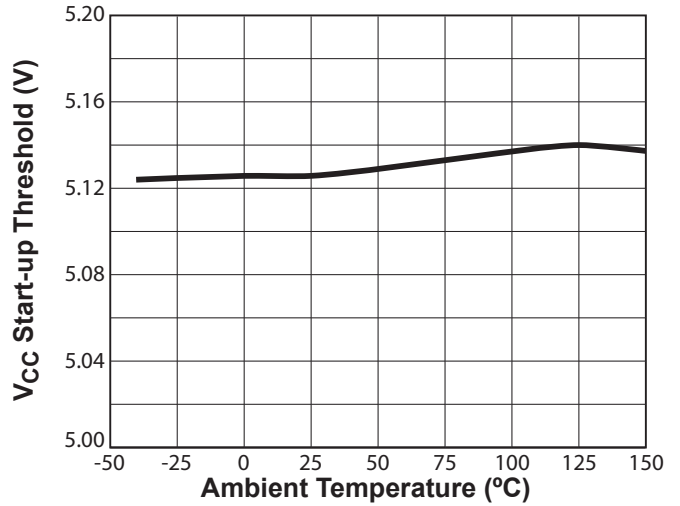

Figure 7.2 : V<sub>CC</sub> Start-Up Threshold vs. Temperature

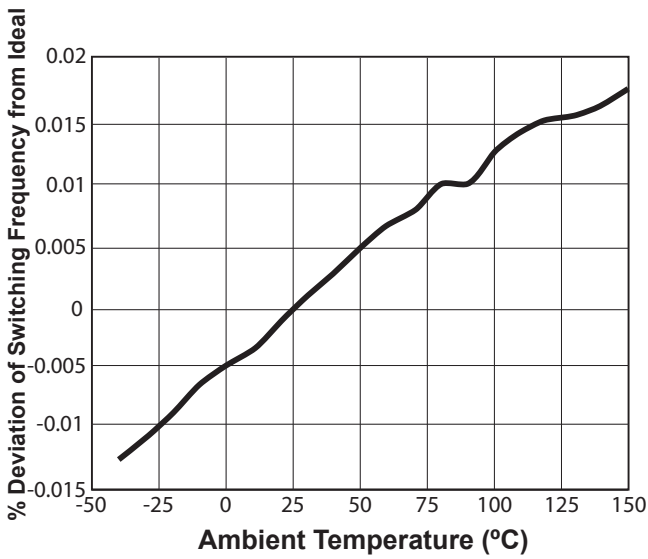

Figure 7.3 : % Deviation of Switching Frequency to Ideal Switching Frequency vs. Temperature

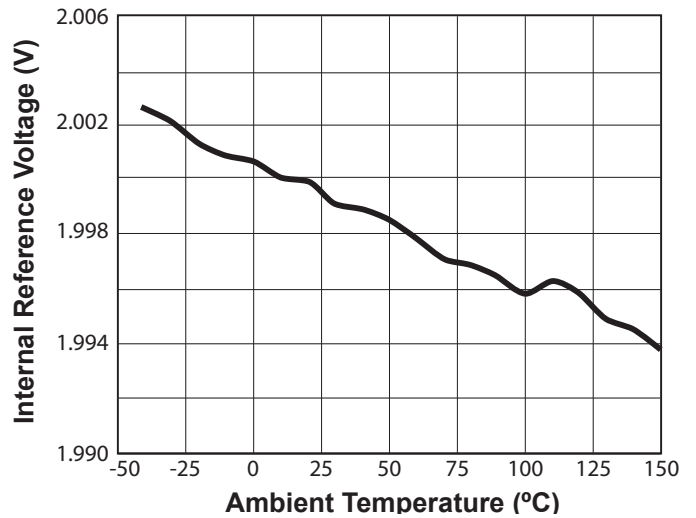

Figure 7.4 : Internal Reference vs. Temperature

## AC/DC Digital Power Controller for Single-Stage High Power Factor Dimmable LED Drivers

### 8 Functional Block Diagram

The Digital Core (shown in Figure 8.1) analyzes the rectified AC waveform and determines whether a dimmer is connected on the line. There are three dimmer modes in the iW3681-20: no-dimmer, leading-edge dimmer, and trailing-edge dimmer. Based on the detected dimmer type and input voltage waveform, the iW3681-20 determines whether to operate in current sink mode or switching mode. During switching mode, the output current regulation is determined by the inductor peak current ( $I_{\text{SENSE}}$  pin), the magnetic flux status of the inductor ( $V_D$  and  $V_{CB}$  pins), and the input voltage waveform ( $V_{\text{IN}}$  pin) (refer to section 9.4 for more information).

If no dimmer is detected on the AC line, the iW3681-20 operates in no-dimmer mode where only the switching circuit is enabled. In this mode, the average output current is regulated to the nominal value and is immune to input voltage variation.

If a dimmer (either leading-edge or trailing-edge) is detected on the AC line, the iW3681-20 operates in dimmer mode. In dimmer mode, MOSFET (Q1 in Figure 11.1) operates in both switching mode and current sink mode based on the timing control of iW3681-20. During the switching mode, the output current is adjusted based on the detected phase conduction angle. During current sink mode, the switching circuit is disabled and the current sink circuit is enabled. The main MOSFET is forced to operate in linear mode, where the current through MOSFET is regulated by the Digital Core. As shown in Figure 8.1,  $V_{\text{CC}}$  can be charged during both current sink mode and switching mode.

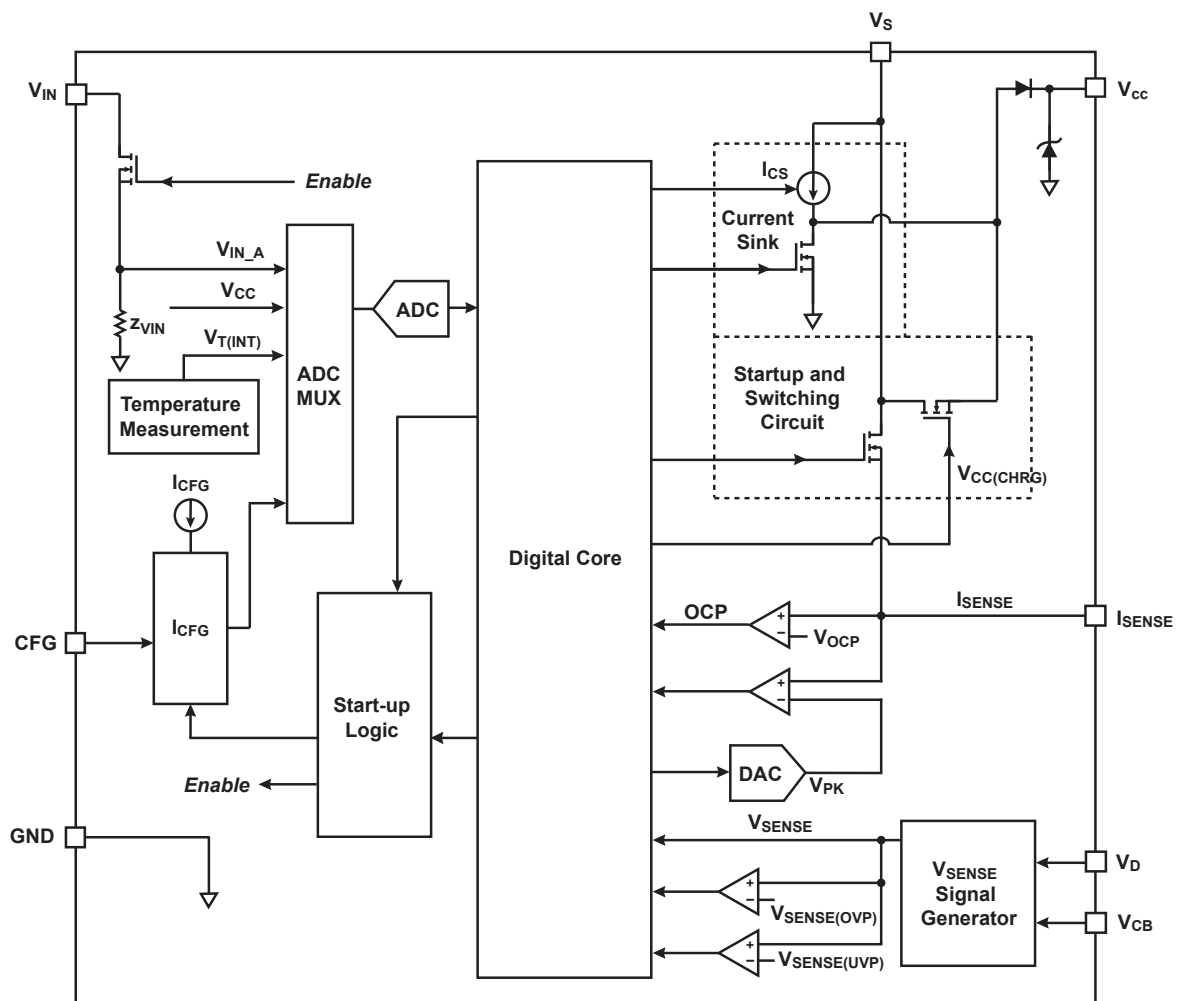

Figure 8.1 : iW3681-20 Functional Block Diagram



## AC/DC Digital Power Controller for Single-Stage High Power Factor Dimmable LED Drivers

### 9 Theory of Operation

#### 9.1 System Startup

This section provides information about iW3681-20 system start up, which includes the IC startup, wall dimmer detection, and the LED current soft start.

##### 9.1.1 IC Startup

When AC voltage is applied, the gate voltage of MOSFET,  $V_G$  is charged up through RC circuit (R6, and C5 in Figure 11.1). When  $V_{GS} > V_{GS(TH)}$ , the MOSFET starts to turn on and charge the  $V_{CC}$  capacitors (C7 and C8 in Figure 11.1). When  $V_{CC}$  voltage reaches  $V_{CC}$  start-up threshold  $V_{CC(ST)}$ , the iW3681-20's control logic is activated and the IC starts up.

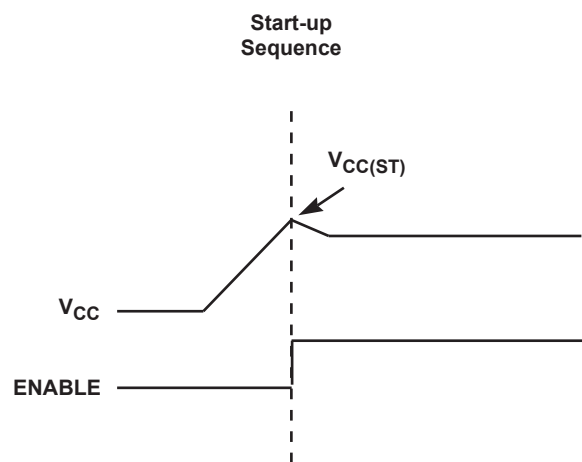

Figure 9.1 : Start-up Sequence Diagram

##### 9.1.2 Wall Dimmer Detection

There are two basic categories of phase-cut wall dimmers: leading-edge dimmers and trailing-edge dimmers. If the AC voltage rises at the phase-cut edge, the dimmer is called leading-edge dimmer (shown in Figure 9.2). Otherwise it is called trailing-edge dimmer (shown in Figure 9.3). Normally, a leading-edge dimmer is either an R-type or RL-type; a trailing-edge dimmer is an RC-type.

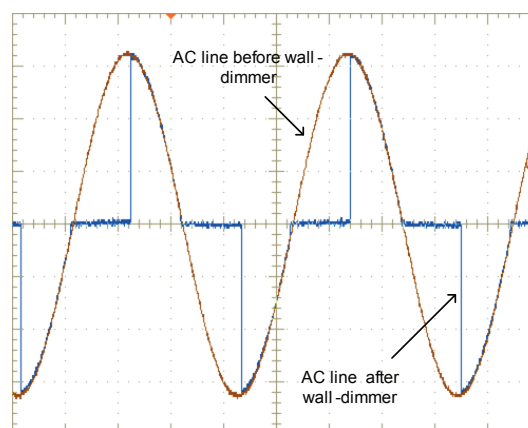
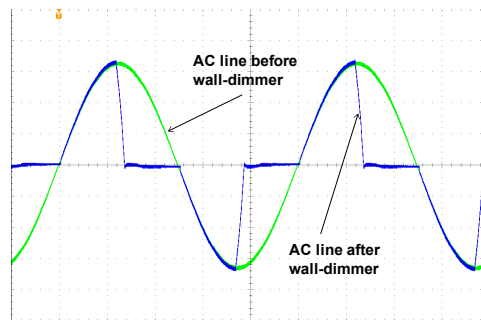

Figure 9.2 : Leading-edge wall dimmer waveforms

**Figure 9.3 : Trailing-Edge Wall Dimmer Waveforms**

The dimmer detection stage occurs in the iW3681-20 immediately after IC starts up. During this stage, the iW3681-20 stays in current sink mode to place a low impedance load on the AC line, where the current through MOSFET is regulated by the Digital Core. As a result, the dimmer type (no-dimmer, leading-edge, or trailing-edge) can be accurately detected.

The dimmer type is determined by sensing the slope of the input AC voltage and the dimming phase angle. A fast rising edge of the input AC voltage indicates a leading-edge dimmer. A large dimming phase angle indicates no dimmer is on the line. Otherwise, a trailing-edge dimmer is detected.

When the  $V_{IN\_A}$  signal is above  $V_{IN(ST)}$  for 500 $\mu$ s and the AC line frequency is within the range, the AC input signal is qualified for startup. If  $V_{CC}$  drops below  $V_{CC(UVL)}$ , the iW3681-20 resets and the startup sequence is initiated.

### 9.1.3 LED Current Soft-Start

After the iW3681-20 qualifies the AC input signal, the buck-boost or flyback converter immediately starts to deliver current to the LED load. A soft-start algorithm is applied to the buck-boost or flyback converter to gradually ramp up the LED current.

If a dimmer is connected, the driver starts immediately into leading-edge or trailing-edge mode operation (refer to section 9.3.1 and 9.3.2 for details) to interface with the dimmer. If no dimmer is connected, the driver starts no-dimmer mode operation (refer to section 9.3.3 for details).

## 9.2 Dimming Curve

When a leading-edge or a trailing-edge dimmer is detected, the iW3681-20 adjusts the output current to a certain ratio of the nominal output current, based on the dimming phase angle detected. This ratio between the desired output current to the nominal output current is called the dimming percentage. A typical mapping between the dimming phase angle and the dimming percentage is shown in Figure 10.6. All the dimming curves of the iW3681-20 fall within the limits of the NEMA SSL6 and SSL7 standard (shown in Figure 10.6). The iW3681-20 updates the dimming percentage every half-AC-cycle based on the detected dimming phase angle to ensure fast dimming response.

## 9.3 Current Sink and Switching Circuit Control

This section provides information about how the iW3681-20 controls the current sink circuit and the switching circuit during leading-edge dimmer mode, trailing-edge dimmer mode, and no-dimmer mode.

### 9.3.1 Leading-Edge and Trailing-Edge Dimmer Mode

Initially, the current sink circuit is enabled to provide a low impedance load to ensure proper functionality of the dimmer, whether leading-edge or trailing-edge. Subsequently, depending upon which dimmer type is detected, the digital algorithms inside the controller enable alternately the current sink function or the switching circuit to deliver the required output current to the LEDs based on the phase angle and controlling the input current of the driver board.

## AC/DC Digital Power Controller for Single-Stage High Power Factor Dimmable LED Drivers

As the dimmer output voltage approaches zero again, the iW3681-20 enables the current sink circuit to discharge the capacitors of the dimmer and driver board.

### 9.3.2 No-dimmer Mode

If there is no dimmer on the line, the iW3681-20 operates in no-dimmer mode to optimize power factor and to minimize harmonic distortion. The current sink circuit is disabled in this mode and only the switching circuit is used.

### 9.3.3 Controller Power Management

Unlike most off-line LED controllers, the iW3681-20 does not rely on an auxiliary winding of the main power inductor/transformer to supply the operating current. Instead, it uses Dialog's proprietary multi-path charging technology to sustain the  $V_{CC}$  voltage. Also, a lower nominal  $V_{CC}$  level is made possible with source switching structure, which reduces the IC power consumption and enables the use of a smaller size  $V_{CC}$  capacitor.

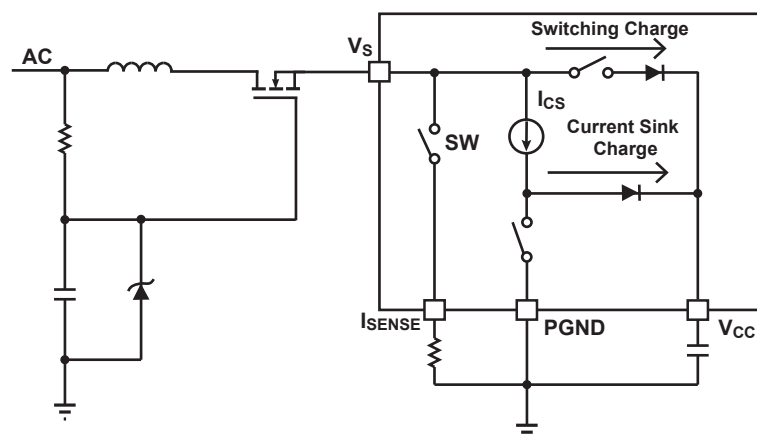

Figure 9.4 :  $V_{CC}$  Charging Circuit

The iW3681-20's operating current is supplied by two paths (shown in Figure 9.4). The first path, called switching charge, re-directs the switching current into the  $V_{CC}$  capacitor when the MOSFET is turned on. The second path, called sinking charge, re-directs the sinking current into  $V_{CC}$  capacitor. When there is no dimmer on the line, only the switching charge is used to achieve high efficiency. When there is a dimmer on the line, both switching and sinking charge are used to ensure  $V_{CC}$  is sustained across the entire dimming range.

The iW3681-20 regulates the  $V_{CC}$  voltage by adjusting the duration of the charging time.  $V_{CC}$  voltage is smoothly regulated to the nominal level when the iW3681-20 operates in no-dimmer mode. When the iW3681-20 operates in dimmer mode, the window for  $V_{CC}$  charging is limited. Therefore, the iW3681-20 charges the  $V_{CC}$  voltage to  $V_{CC(HIGH)}$  in the charging window. Although  $V_{CC}$  voltage droops before next charging window, the iW3681-20 guarantees  $V_{CC}$  level is always above  $V_{CC(UVL)}$  when a proper sized  $V_{CC}$  capacitor is used.

## 9.4 Output Current Regulation

This section provides information about iW3681-20 output current regulation, which incorporates the Dialog-patented **PrimAccurate™** technology.

## AC/DC Digital Power Controller for Single-Stage High Power Factor Dimmable LED Drivers

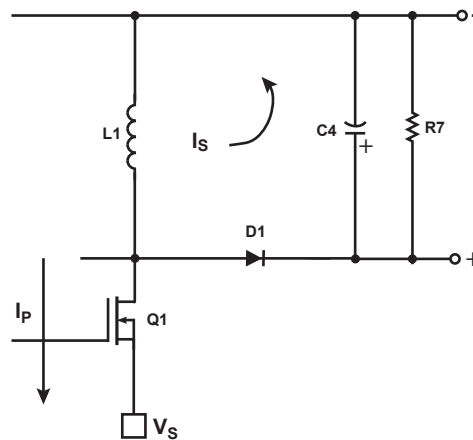

Figure 9.5 : Inductor Current Flow in Switching Mode

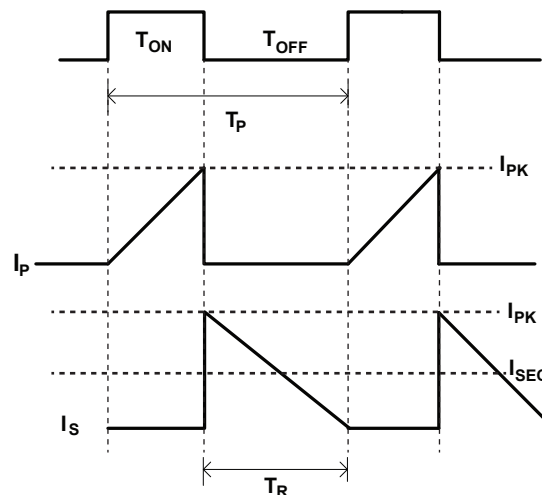

Figure 9.6 : Cycle-to-Cycle Peak Current Regulation

In iW3681-20, output current regulation is implemented through peak current control in switching mode. Figure 9.5 and 9.6 show the basic principle of this peak current regulation during the switching mode. During  $T_{ON}$ , the main switch Q1 (shown in Figure 9.5) is turned on and the current,  $I_P$ , flows through the primary side of the buck-boost converter and Q1.  $I_P$  ramps up linearly and causes energy to build up in the power inductor L1 (shown in Figure 9.5). The iW3681-20 continuously monitors  $I_{SENSE}$  pin voltage, when it reaches  $V_{PK}$  (shown in Figure 8.1), it turns off the switching circuit. At this time,  $I_P$  reaches peak current regulation level  $I_{PK}$  (shown in Figure 9.5 and 9.6). After Q1 is turned off, the current in L1 ramps down linearly through D1 (shown in Figure 9.5), until the energy stored in the power inductor is discharged. During this period, the current through L1 flows to the secondary side of the buck-boost/flyback converter, which is called  $I_S$ .

### 9.4.1 Output Current Regulation in No-Dimmer Mode

In no-dimmer mode,  $V_{PK}$  is designed to be proportional to the input voltage shape with a lower limit at the  $V_{IN}$  falling edge and a configurable limit at the  $V_{IN}$  rising edge. As shown in Figure 9.7, the  $V_{PK}$  clamp value at  $V_{IN}$  rising edge can be configured by the resistor and capacitor connected to the CFG pin, which is illustrated in section 9.5. The buck-boost or flyback converter operates in critical discontinuous conduction mode (CDCM) if the switching frequency of

## AC/DC Digital Power Controller for Single-Stage High Power Factor Dimmable LED Drivers

main MOSFET does not exceed the  $f_{SW(MAX)}$ . Otherwise, if the switching frequency reaches the  $f_{SW(MAX)}$ , the power converter operates in discontinuous conduction mode (DCM).

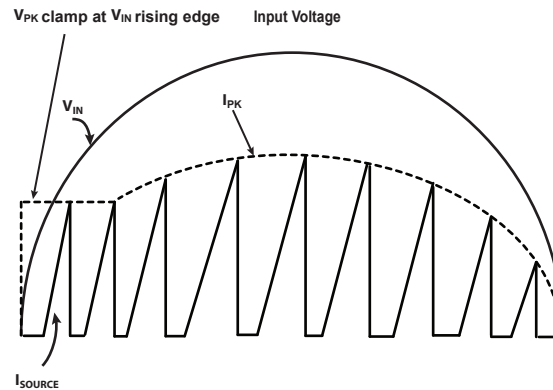

**Figure 9.7 : Peak Current Regulation in No-Dimmer Mode**

As shown in Figure 9.6, the average current of  $I_S$  in one switching cycle can be expressed by  $I_{SEC}$ , where

$$I_{SEC} = 0.5 \times N_{TR} \times I_{PK} \times \frac{T_R}{T_P} \quad (9.1)$$

where  $I_{PK}$  is the peak value of the primary winding current.  $N_{TR}$  is the primary-secondary turns ratio. For single winding inductor topology as shown in Figure 9.5,  $N_{TR} = 1$ .  $T_R$  is the secondary-side current ramp-down time, and  $T_P$  is the entire switching period.

The  $I_{PK}$  is determined by the voltage generated on the current sense resistor R19 (shown in Figure 11.1):  $I_{PK} = V_{PK} / R19$ . Therefore, the equation can be written as

$$I_{SEC} = 0.5 \times N_{TR} \times \frac{V_{PK}}{R19} \times \frac{T_R}{T_P} \quad (9.2)$$

In steady state, the average output current is equal to the average  $I_{SEC}$  over one half-AC-cycle. Therefore, the average output current can be obtained by averaging equation 9.2 over one half-AC-cycle.

The iW3681-20 regulates the averaged  $V_{PK} * (T_R/T_P)$  to be a constant over one AC half cycle. Therefore, the nominal output current  $I_{OUT(NOM)}$  can be determined by equation 9.3.

$$I_{OUT(NOM)} = 0.5 \times \frac{N_{TR}}{R19} \times 0.35V \times \eta \quad (9.3)$$

$\eta$  is ideally equal to 1.0 for single-inductor scheme.

### 9.4.2 Output Current Regulation in Dimmer Mode

In dimmer mode,  $V_{PK}$  is a fixed value determined by the configuration resistor (see section 9.5). If the buck-boost or flyback is operating in DCM, a fixed  $V_{PK}$  and PWM switching cycles control can achieve stable  $I_{SEC}$  regulation because the energy delivered to the LED is fixed regardless of input voltage variation. If the buck-boost or flyback is operating in CCM, this stable  $I_{SEC}$  regulation cannot be guaranteed. Therefore, the preset  $V_{PK}$  value needs to ensure the buck-boost or flyback is operating in DCM. When  $V_{IN}$  is low, the iW3681-20 drops the  $V_{PK}$  level to ensure DCM operation (see Figure 9.8).

## AC/DC Digital Power Controller for Single-Stage High Power Factor Dimmable LED Drivers

Company Confidential

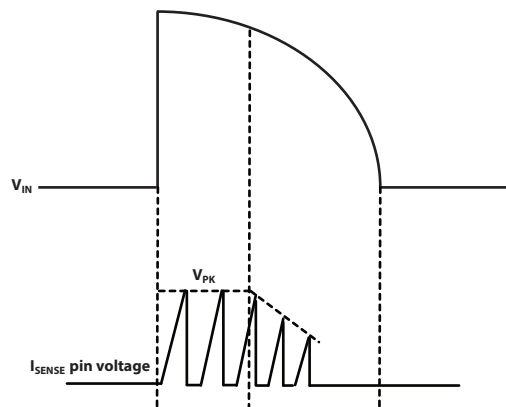

**Figure 9.8 : Peak Current Regulation in Dimmer Mode**

During dimmer mode operation, the output current is regulated with a closed-loop control. The reference output current,  $I_{OUT(DIM)}$ , is calculated by equation 9.4. The instantaneous  $I_{SEC}$  current delivered to the output side is accumulated every switching cycle when switching is enabled.

$$I_{OUT(DIM)} = I_{OUT(NOM)} \times \text{dimming percentage} \quad (9.4)$$

When the accumulated instantaneous  $I_{SEC}$  current in one half-AC-cycle reaches  $I_{OUT(DIM)}$ , the iW3681-20 disables the switching circuit.

### 9.5 Configuration Function

At start-up, a current source in the iW3681-20 drives the configuration current  $I_{CFG}$  (100 $\mu$ A) into the CFG pin (shown in Figure 8.1). The iW3681-20 reads the pin voltage to determine the configuration option. The CFG pin configuration selects the temperature de-rating start point (OTP),  $V_{PK}$  high limit value at dimmer mode, and  $V_{IN}$  rising edge  $V_{PK}$  clamp value at no dimmer mode. The iW3681-20 can use either a single CFG resistor to ground for programming the configuration function, or it can use an RC configuration method to achieve more configuration flexibility. The CFG pin monitors two voltage sample points as shown on figure 9.9. The first point is set by the resistor value from CFG to ground and the second is set by the RC time constant if a capacitor is placed in parallel with the CFG resistor. Based on these two sample points, the iW3681-20 sets the functionality shown in table 9.1. The iW3681-20 can determine whether the capacitor is used in parallel with the resistor or not and program the configuration function accordingly.

## AC/DC Digital Power Controller for Single-Stage High Power Factor Dimmable LED Drivers

Company Confidential

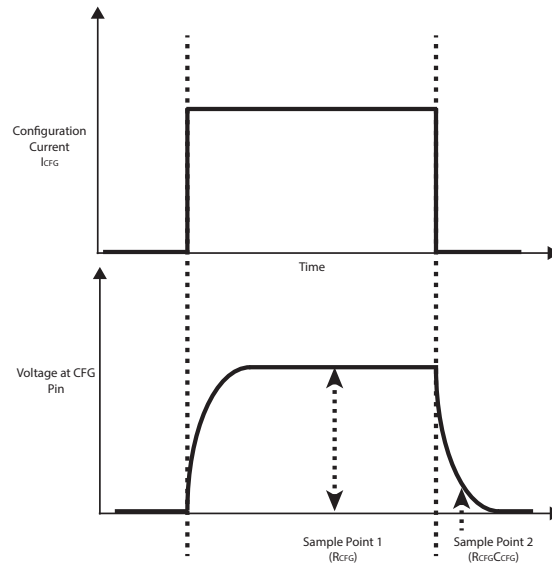

Figure 9.9 : Configuration Pin (CFG) Timing Waveform

CFG Pin Resistor (R17 in Fig. 11.1)			No CFG Capacitor		CFG Capacitor (2.2nF)	
Min Value (k $\Omega$ )	Typical Value (k $\Omega$ )	Max Value (k $\Omega$ )	OTP Starting Point (°C)	V <sub>PK</sub> at Dimmer Mode (V)/V <sub>IN</sub> Rising Edge V <sub>PK</sub> Clamp Value at No Dimmer Mode	OTP Starting Point (°C)	V <sub>PK</sub> at Dimmer Mode (V)/V <sub>IN</sub> Rising Edge V <sub>PK</sub> Clamp Value at No Dimmer Mode
17.82	18.0		disabled	1.05/0.45	105	1.05/0.45
	0.40	0.69	105	0.95/0.4	105	0.95/0.4
1.39	1.65	1.91	105	0.85/0.35	105	0.85/0.35
2.78	3.0	3.22	105	0.75/0.3	105	0.75/0.3
4.28	4.45	4.62	115	1.05/0.45	125	1.05/0.45
5.88	6.05	6.22	115	0.95/0.4	125	0.95/0.4
7.70	7.85	8.00	115	0.85/0.35	125	0.85/0.35
9.74	9.88	10.01	115	0.75/0.3	125	0.75/0.3
12.04	12.18	12.31	135	0.95/0.4	135	1.05/0.45
14.67	14.85	15.03	135	0.75/0.3	135	0.85/0.35

Table 9.1 CFG Pin Configuration Resistor Values

## AC/DC Digital Power Controller for Single-Stage High Power Factor Dimmable LED Drivers

Company Confidential

### 9.6 $V_{SENSE}$ Direct Sensing

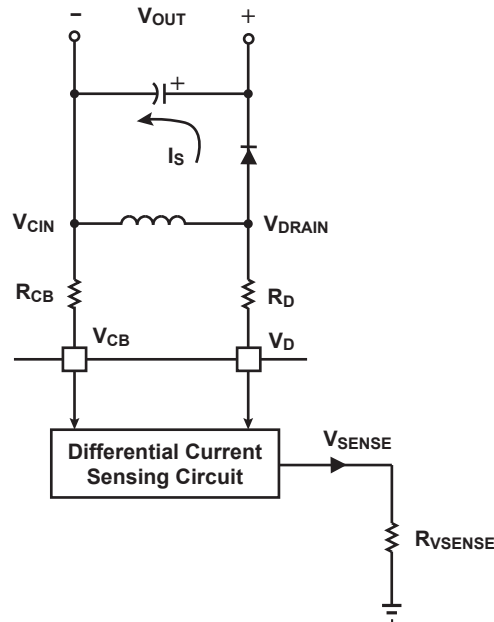

Figure 9.10 :  $V_{SENSE}$  Circuit Inside iW3681-20

In conventional LED driver solutions, there is an auxiliary winding in the main inductor/transformer. Three main functions of this auxiliary winding are: 1. To supply  $V_{CC}$  for controller IC; 2. To provide output voltage information; 3. To provide magnetic flux information of the inductor. As mentioned in section 9.3.4, the iW3681-20 does not rely on an auxiliary winding to charge  $V_{CC}$ . Dialog's proprietary  $V_{SENSE}$  Direct Sensing technology allows the iW3681-20 to obtain LED output voltage and magnetic flux information without an auxiliary winding.

Inside the iW3681-20, there is a high performance differential current sensing circuit between the  $V_D$  and  $V_{CB}$  pins (shown in Figure 9.10). This circuit generates a differential current that is equal to the current flow into  $V_D$  pin subtracted by the current flow into  $V_{CB}$  pin. This differential current is directed to an internal resistor,  $R_{VSENSE}$  ( $R_{VSENSE} = 25k\Omega$ ), to generate a voltage called  $V_{SENSE}$ .  $V_{SENSE}$  is essentially a scaled-down version of  $V_{DRAIN}$  minus  $V_{CIN}$ , which is the same as the auxiliary winding generated signal.

The resistances of  $R_{CB}$  and  $R_D$  are determined by the nominal output voltage,  $V_{OUT}$ . In Figure 11.1  $R_{CB}$  refers to R13, and  $R_D$  refers to R15.

$$V_{SENSE} = \left( \frac{V_{DRAIN}}{R_D} - \frac{V_{CIN}}{R_{CB}} \right) \times R_{VSENSE} \quad (9.5)$$

During the period of  $T_R$  (shown in Figure 9.8),  $V_{DRAIN}$  minus  $V_{CIN}$  is approximately equal to  $V_{OUT}$ . By making  $R_{CB}$  and  $R_D$  the same, their values can be determined by

$$R_{CB} = R_D = \frac{V_{OUT}}{V_{SENSE}} \times R_{VSENSE} \quad (9.6)$$

The recommended nominal  $V_{SENSE}$  voltage  $V_{SENSE(NOM)}$  is 1.5V.



## AC/DC Digital Power Controller for Single-Stage High Power Factor Dimmable LED Drivers

Company Confidential

### 9.7 Protection Features

This section provides information about iW3681-20 protection features.

#### 9.7.1 Output Over-Voltage/LED Open Protection

The iW3681-20 includes a function that protects against an output over-voltage.

The output voltage is monitored by the  $V_{SENSE}$  voltage (refer to Section 9.6). If the  $V_{SENSE}$  voltage exceeds  $V_{SENSE(OVP)}$ , which is 1.95V, the iW3681-20 shuts down the switching circuit and current sink circuit (shown in Figure 8.1) immediately. As a result, MOSFET is turned off. After the shutdown of current sink and switching circuits, the iW3681-20 remains powered, while  $V_{CC}$  continues to discharge. In order to avoid over-charging of the output voltage, the iW3681-20 employs an extended discharge time as described below if  $V_{CC}$  does not drop below  $V_{CC(UVL)}$ . Otherwise, when  $V_{CC}$  drops below  $V_{CC(UVL)}$ , the iW3681-20 resets itself and then initiates a new soft-start cycle.

Under the fault condition, the iW3681-20 tries to start up for three consecutive times. If all three start-up attempts fail, the iW3681-20 enters an inactive mode, during which the iW3681-20 does not respond to the  $V_{CC}$  power-on requests. The iW3681-20 is activated again after it sees 29 start-up attempts. Typically, this extended discharge time is around three to five seconds.

#### 9.7.2 Output Short Protection

The iW3681-20 includes a function that protects against an output short-circuit fault.

When output is shorted,  $V_{SENSE}$  is below  $V_{SENSE(UVP)}$ , which is 0.15V. As a result, an output short fault is detected. The iW3681-20 shuts down the switching circuit and current sink circuit (shown in Figure 8.1) immediately. As a result, MOSFET is turned off. After the turn-off of MOSFET, the iW3681-20 remains powered while  $V_{CC}$  continues to discharge. In order to avoid excessive power stress due to auto-restart, the iW3681-20 employs an extended discharge time as described in section 9.7.1, if  $V_{CC}$  does not drop below  $V_{CC(UVL)}$ . Otherwise, when  $V_{CC}$  drops below  $V_{CC(UVL)}$ , the iW3681-20 resets itself and then initiates a new soft-start cycle.

To support applications with high output capacitance, output short protection is not activated during the initial LED current soft start period. This allows the voltage to build up in the output capacitor without triggering the protection.

#### 9.7.3 Temperature De-Rating and Over-Temperature Protection

The iW3681-20 can detect and protect against over-temperature event. The iW3681-20 utilizes an internal sensor for temperature measurement.

When the monitored temperature reaches  $T_{DERATE(ST)}$ , the maximum output current limit begins to reduce linearly from 100% to 70% of the nominal value until the temperature reaches  $T_{DERATE(FINISH)}$  threshold as shown in Figure 9.11, where  $T_{DERATE(FINISH)} = T_{DERATE(ST)} + 20^{\circ}\text{C}$ . At  $T_{DERATE(FINISH)}$ , the maximum output current limit is clamped to 70%. If the temperature further increases to  $T_{OTP(START)}$ , the iW3681-20 shuts down.

The iW3681-20 remains in shutdown mode as long as the monitored temperature is above  $T_{OTP(START)}$ . If the detected temperature falls below  $T_{OTP(START)}$  at anytime, the iW3681-20 starts up. From  $T_{DERATE(FINISH)}$  to  $T_{DERATE(ST)}$ , the maximum output current limit increases linearly from 70% to 100% as shown in Figure 9.11. The device goes back to normal operation if the sensed temperature falls below  $T_{DERATE(ST)}$ . This bi-directional operation enables the LED current thermal fold-back instead of an abrupt shut-down of the LED current.

The values of  $T_{DERATE(ST)}$  and  $T_{DERATE(FINISH)}$  can be adjusted through the CFG pin resistor (refer to Section 9.5).

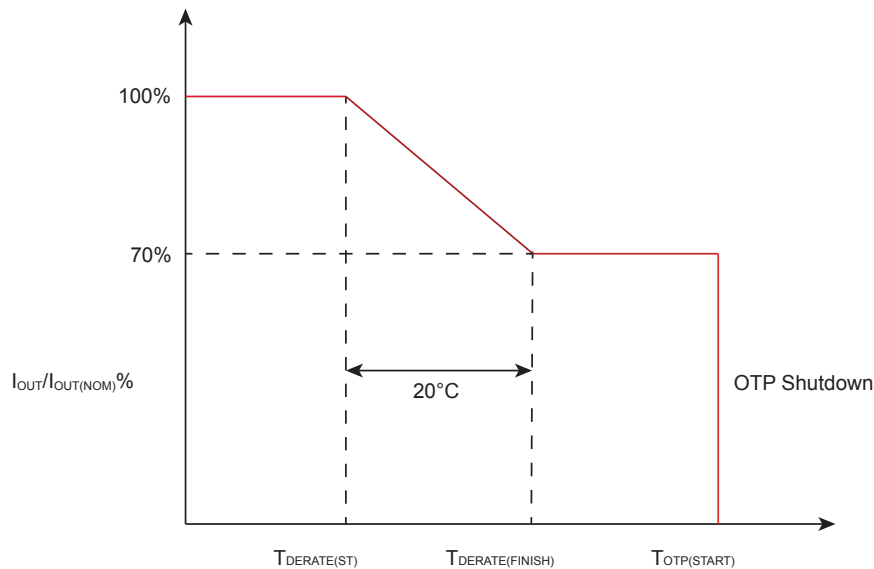
**Figure 9.11 : Temperature De-Rating and OTP**

#### 9.7.4 Over-Current Protection

Over-current protection (OCP) is a feature that is built into the iW3681-20.

With the  $I_{SENSE}$  pin, the iW3681-20 is able to monitor the primary peak current of the buck-boost or flyback converter during switching mode. This allows for cycle-by-cycle peak current control and limit. When the primary peak current multiplied by the  $I_{SENSE}$  pin sensing resistor (R19 in Figure 11.1) is greater than  $V_{OCP}$ , over-current is detected and the iW3681-20 immediately shuts down the switching circuit until the next switching cycle. The switching circuit sends out switching pulse in the next switching cycle, and the switching pulse continues if  $V_{OCP}$  is not reached; or, if  $V_{OCP}$  is reached, the switching pulse turns off again.

#### 9.7.5 Current Sensing Resistor Short Protection

The iW3681-20 uses a MOSFET as its main switch for the buck-boost or flyback converter. If the  $I_{SENSE}$  pin sensing resistor (R19 in Figure 11.1) is shorted, there is a potential danger of the over-current condition not being detected. Thus the iW3681-20 is designed to detect this sensing-resistor short fault. When the sensing resistor short fault is detected, the iW3681-20 shuts down the switching circuit and current sink circuit (shown in Figure 8.1) immediately. As a result, MOSFET is turned off. After the turn-off of MOSFET, the iW3681-20 remains powered while  $V_{CC}$  continues to discharge. In order to prevent over-stress of power circuit components, the iW3681-20 employs an extended discharge time as described in section 9.7.1 if  $V_{CC}$  does not drop below  $V_{CC(UVL)}$ . Otherwise, when  $V_{CC}$  drops below  $V_{CC(UVL)}$ , the iW3681-20 resets itself and then initiates a new soft-start cycle.

#### 9.7.6 Current Sense Resistor Open Protection

If the  $I_{SENSE}$  pin sensing resistor (R19 in Figure 11.1) is open and not being detected, it may cause potential damage to the internal circuit during the switching mode. Thus, the iW3681-20 is designed to detect  $I_{SENSE}$  pin open fault. When the  $I_{SENSE}$  pin open fault is detected, the iW3681-20 shuts down the switching circuit and current sink circuit (shown in Figure 8.1) immediately. As a result, MOSFET is turned off. After the turn-off of MOSFET, the iW3681-20 remains powered while  $V_{CC}$  continues to discharge. In order to prevent over-stress of power circuit components, the iW3681-20 employs an extended discharge time as described in section 9.7.1 if  $V_{CC}$  does not drop below  $V_{CC(UVL)}$ . Otherwise, when  $V_{CC}$  drops below  $V_{CC(UVL)}$ , the iW3681-20 resets itself and then initiates a new soft-start cycle.

10 Dimming Performance Characteristics

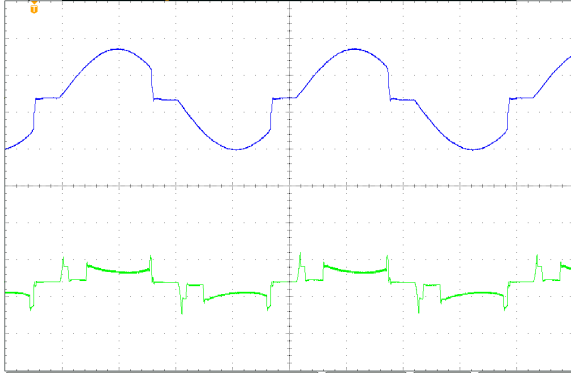

Figure 10.1 : Trailing-Edge Dimmer (Large Phase)

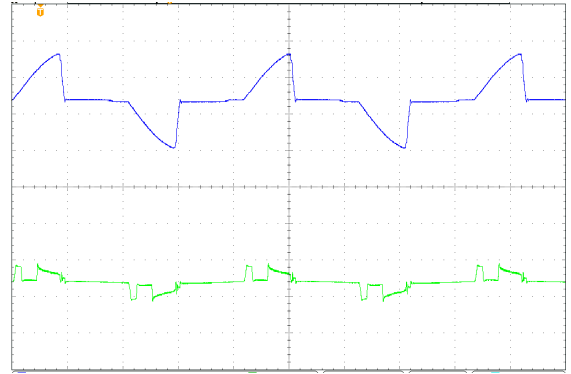

Figure 10.2 : Trailing-Edge Dimmer (Small Phase)

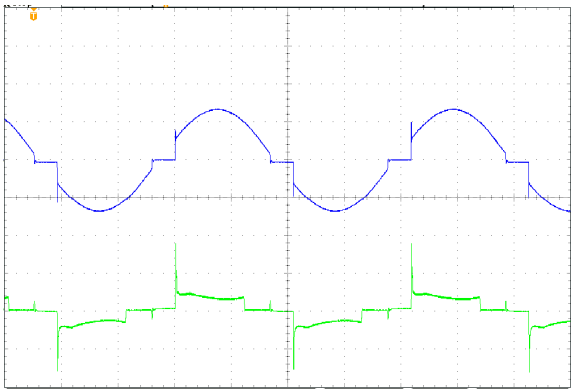

Figure 10.3 : Leading-Edge Dimmer (Large Phase)

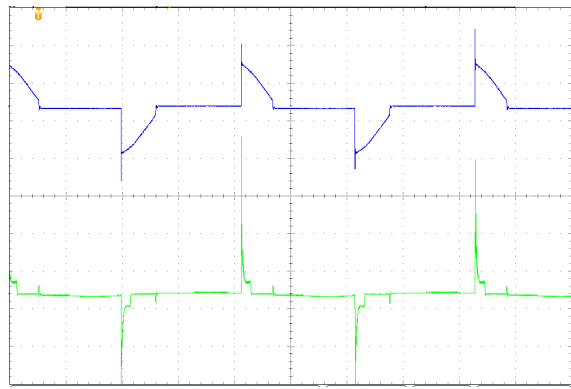

Figure 10.4 : Leading-Edge Dimmer (Small Phase)

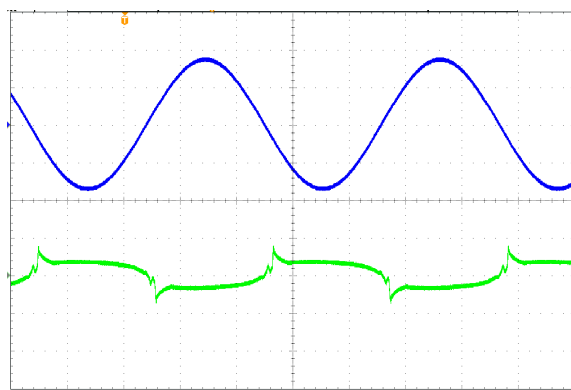

Figure 10.5 : No Dimmer

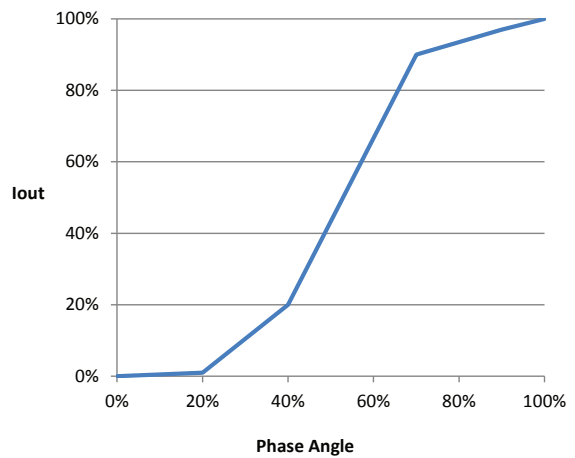

Figure 10.6 : Typical Dimming Curve

11 Typical Application Schematic

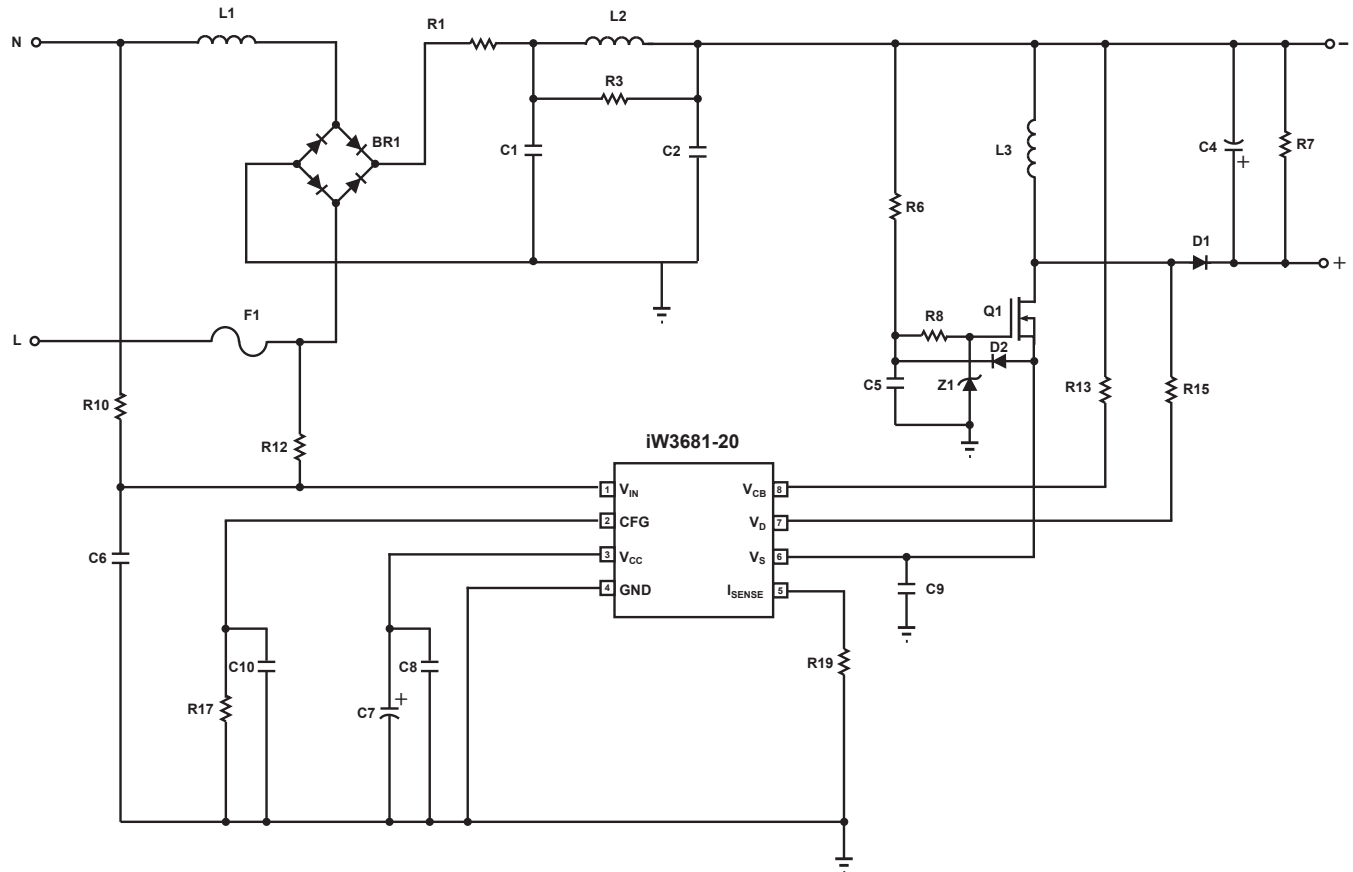

Figure 11.1 : iW3681-20 Application Circuit

12 Product Navigation

For 25W or higher power applications, visit the products below:

Part Number	Options
iW3600-00 or iW3605-02	120V <sub>AC</sub> input
iW3600-01 or iW3605-02	230V <sub>AC</sub> input

**AC/DC Digital Power Controller for Single-Stage High Power Factor Dimmable LED Drivers**

**13 Physical Dimensions**

8-Lead Small Outline (SOIC) Package

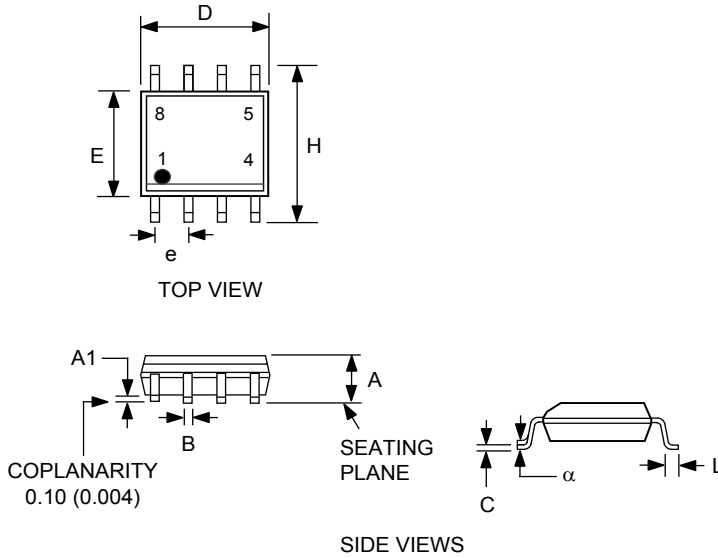

Symbol	Inches		Millimeters	
	MIN	MAX	MIN	MAX
A	0.053	0.069	1.35	1.75
A1	0.0040	0.010	0.10	0.25
B	0.014	0.019	0.35	0.49
C	0.007	0.010	0.19	0.25
D	0.189	0.197	4.80	5.00
E	0.150	0.157	3.80	4.00
e	0.050 BSC		1.27 BSC	
H	0.228	0.244	5.80	6.20
L	0.016	0.049	0.40	1.25
$\alpha$	0°	8°		

Compliant to JEDEC Standard MS12F

Controlling dimensions are in inches; millimeter dimensions are for reference only

This product is RoHS compliant and Halide free.

Soldering Temperature Resistance:

[a] Package is IPC/JEDEC Std 020D moisture sensitivity level 1

[b] Package exceeds JEDEC Std No. 22-A111 for solder immersion resistance; package can withstand 10 s immersion < 260°C

Dimension D does not include mold flash, protrusions or gate burrs. Mold flash, protrusions or gate burrs shall not exceed 0.15 mm per end. Dimension E1 does not include interlead flash or protrusion. Interlead flash or protrusion shall not exceed 0.25 mm per side.

The package top may be smaller than the package bottom. Dimensions D and E1 are determined at the outermost extremes of the plastic body exclusive of mold flash, tie bar burrs, gate burrs and interlead flash, but including any mismatch between the top and bottom of the plastic body.

**14 Ordering Information**

Part Number	Options	Package	Description
iW3681-20	120V <sub>AC</sub> Input for up to 25W (see Note 1 on page 2)	SOIC-8	Tape & Reel <sup>2</sup>

**Note 2: Tape and reel packing quantity is 2,500/reel. Minimum ordering quantity is 2,500.**