

nRF21540

Objective Product Specification

v0.5.2

Key features

Key features:

- Supports *Bluetooth*[®] Low Energy, 802.15.4, and proprietary applications
- Max output power 22 dBm
- Adjustable output power to ± 1 dB from 5 to 21 dBm
- User programmable modes for TX gain
- Support for two antenna interfaces
- Receive gain +13 dB
- Single-ended 50 Ω matched input and output
- 115 mA @ +20 dBm output power
- 42 mA @ +10 dBm output power
- Control interface via IO, SPI, or a combination of both
- Supply voltage 1.7 to 3.6 V, suitable for 1.8+/-5% systems
- Operating temperature -40°C to 105°C
- Package variant QFN16 4 x 4 mm

Applications:

- Smart Home applications
- Industrial and factory automation
- Asset tracking
- Advanced CE remote controls
- Sports and Fitness
- Toys
- Medical
- Beacons

Contents

Key features	ii
1 Revision history	5
2 Product overview	6
3 About this document	7
3.1 Document status	7
3.2 Peripheral chapters	7
3.3 Register tables	7
3.3.1 Fields and values	8
3.3.2 Permissions	8
3.4 Registers	8
3.4.1 DUMMY	8
4 Block diagram	10
5 Device control	11
5.1 Operational states	11
5.2 State transition timing	12
5.3 TX power control	13
5.4 UICR program usage	14
6 SPI interface	15
7 Electrical specification	17
7.1 Electrical specification	17
7.1.1 Current consumption	17
7.1.2 RX	17
7.1.3 TX	17
7.1.4 SPI timing specification	18
8 Register interface	19
8.1 Registers	19
8.1.1 CONFREG0	19
8.1.2 CONFREG1	19
8.1.3 CONFREG2	20
8.1.4 CONFREG3	20
8.1.5 PARTNUMBER	20
8.1.6 HW_REVISION	21
8.1.7 HW_ID0	21
8.1.8 HW_ID1	21
9 Hardware and layout	22
9.1 Pin assignments	22
9.2 Reference circuitry	23
10 Recommended operating conditions	24

11	Absolute maximum ratings.	25
12	Legal notices.	26

1 Revision history

Date	Version	Description
Dec 2019	0.5.2	First release

2 Product overview

nRF21540 is an RF front-end module suitable for Bluetooth Low Energy and IEEE 802.15.4 range extension.

Features include a configurable gain Power amplifier (PA) in the transmit path (TX) and Low noise amplifier (LNA) in the receive path (RX). Single-ended operation on both TRX and ANT1/2 ports is supported and requires only three external components (for single antenna operation) for the RF path.

The device is controlled through a set of input pins and/or through the SPI interface, by writing to internal control registers. The two antenna ports enable applications using antenna diversity and can be selected using pin ANT_SEL.

The device features highly configurable gain in Transmit state, enabling the application to implement adaptive gain control algorithms.

3 About this document

This document is organized into chapters that are based on the modules and peripherals available in the IC.

3.1 Document status

The document status reflects the level of maturity of the document.

Document name	Description
Objective Product Specification (OPS)	Applies to document versions up to 1.0. This document contains target specifications for product development.
Product Specification (PS)	Applies to document versions 1.0 and higher. This document contains final product specifications. Nordic Semiconductor ASA reserves the right to make changes at any time without notice in order to improve design and supply the best possible product.

Table 1: Defined document names

3.2 Peripheral chapters

Every peripheral has a unique capitalized name or an abbreviation of its name, e.g. TIMER, used for identification and reference. This name is used in chapter headings and references, and it will appear in the ARM[®] Cortex[®] Microcontroller Software Interface Standard (CMSIS) hardware abstraction layer to identify the peripheral.

The peripheral instance name, which is different from the peripheral name, is constructed using the peripheral name followed by a numbered postfix, starting with 0, for example, TIMER0. A postfix is normally only used if a peripheral can be instantiated more than once. The peripheral instance name is also used in the CMSIS to identify the peripheral instance.

The chapters describing peripherals may include the following information:

- A detailed functional description of the peripheral
- Register configuration for the peripheral
- Electrical specification tables, containing performance data which apply for the operating conditions described in [Recommended operating conditions](#) on page 24.

3.3 Register tables

Individual registers are described using register tables. These tables are built up of two sections. The first three colored rows describe the position and size of the different fields in the register. The following rows describe the fields in more detail.

3.3.1 Fields and values

The **Id (Field Id)** row specifies the bits that belong to the different fields in the register. If a field has enumerated values, then every value will be identified with a unique value id in the **Value Id** column.

A blank space means that the field is reserved and read as undefined, and it also must be written as 0 to secure forward compatibility. If a register is divided into more than one field, a unique field name is specified for each field in the **Field** column. The **Value Id** may be omitted in the single-bit bit fields when values can be substituted with a Boolean type enumerator range, e.g. true/false, disable(d)/enable(d), on/off, and so on.

Values are usually provided as decimal or hexadecimal. Hexadecimal values have a 0x prefix, decimal values have no prefix.

The **Value** column can be populated in the following ways:

- Individual enumerated values, for example 1, 3, 9.
- Range of values, e.g. [0..4], indicating all values from and including 0 and 4.
- Implicit values. If no values are indicated in the **Value** column, all bit combinations are supported, or alternatively the field's translation and limitations are described in the text instead.

If two or more fields are closely related, the **Value Id**, **Value**, and **Description** may be omitted for all but the first field. Subsequent fields will indicate inheritance with '..!'.
..!

A feature marked **Deprecated** should not be used for new designs.

3.3.2 Permissions

Different fields in a register might have different access permissions enforced by hardware.

The access permission for each register field is documented in the **Access** column in the following ways:

Access	Description	Hardware behavior
RO	Read-only	Field can only be read. A write will be ignored.
WO	Write-only	Field can only be written. A read will return an undefined value.
RW	Read-write	Field can be read and written multiple times.
W1	Write-once	Field can only be written once per reset. Any subsequent write will be ignored. A read will return an undefined value.
RW1	Read-write-once	Field can be read multiple times, but only written once per reset. Any subsequent write will be ignored.

Table 2: Register field permission schemes

3.4 Registers

Register	Offset	Description
DUMMY	0x514	Example of a register controlling a dummy feature

Table 3: Register overview

3.4.1 DUMMY

Address offset: 0x514

Example of a register controlling a dummy feature

Bit number		31 30 29 28 27 26 25 24 23 22 21 20 19 18 17 16 15 14 13 12 11 10 9 8 7 6 5 4 3 2 1 0																															
ID		D D D D				C C C			B				A A																				
Reset 0x00050002		0 0 0 0 0 0 0 0 0 0 0 0 0 0 1 0 1 0 0 0 0 0 0 0 0 0 0 0 0 0 0 0 0 0 0 0 1 0																															
ID	Acce Field	Value ID	Value	Description																													
A	RW FIELD_A			Example of a read-write field with several enumerated values																													
		Disabled	0	The example feature is disabled																													
		NormalMode	1	The example feature is enabled in normal mode																													
		ExtendedMode	2	The example feature is enabled along with extra functionality																													
B	RW FIELD_B			Example of a deprecated read-write field Deprecated																													
		Disabled	0	The override feature is disabled																													
		Enabled	1	The override feature is enabled																													
C	RW FIELD_C			Example of a read-write field with a valid range of values																													
		ValidRange	[2..7]	Example of allowed values for this field																													
D	RW FIELD_D			Example of a read-write field with no restriction on the values																													

4 Block diagram

The block diagram illustrates the overall system.

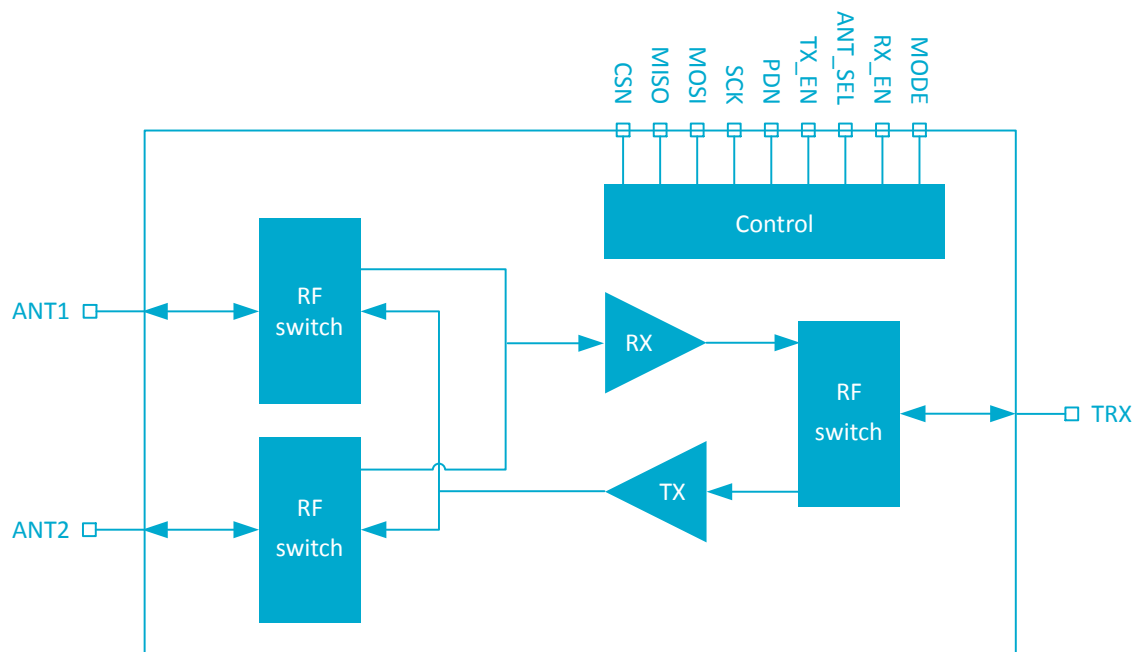

Figure 1: nRF21540 Block diagram

5 Device control

5.1 Operational states

This section describes how nRF21540 can be set to different operational states.

When PDN is set to 0, the device is in Power-down state. When PDN is set to 1, the device is in the Program state. It can be set to any other state (Receive, Transmit, and UICR Program) using pin control or the SPI interface.

State transitions are controlled by pins PDN, RX_EN, and TX_EN or bit fields in SPI registers 0x00 and 0x01. For example, if RX_EN is set to 1 in Program state, the device will enter the Receive state. Similarly, if TX_EN is set to 1 in Program state, the device will enter the Transmit state. If RX_EN is set to 0 during the Receive state, and TX_EN is set to 1 at the same write cycle, then the state changes first to the Program state and then to the Transmit state. If both RX_EN and TX_EN are set to 1 when the device is in the Program state, the device will stay in the Program state (i.e. the operational state does not change). State transitions are shown in the following figure. For details regarding timings required when switching between operating states, see [State transition timing](#) on page 12.

When the device is in the Receive state, the receive path is active and the transmit path is disabled. When the device is in the Transmit state, the transmit path is enabled and the receive path is disabled.

When the device is in the Receive state, CSN needs to be driven low when either pin RX_EN or an SPI command is used for control, as shown in [Figure 4: Control pin controls state change](#) on page 13.

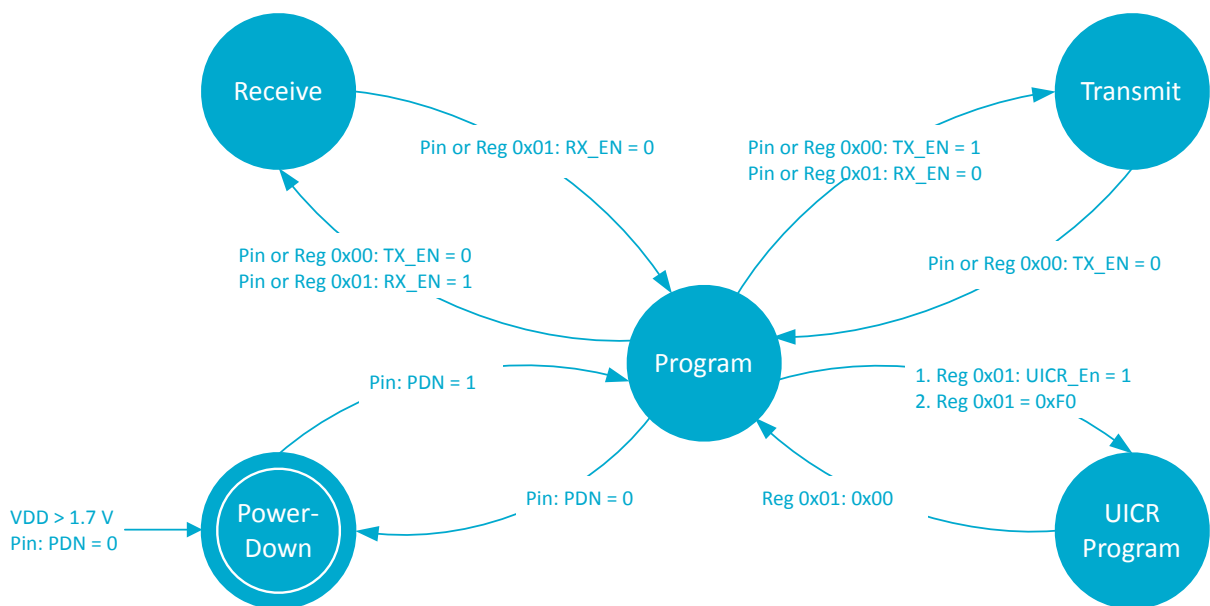

Figure 2: State diagram

The device features a configurable TX output power. See [TX power control](#) on page 13 for details.

UICR (user information configuration register) Program state programs default settings for TX power control to UICR EFUSE (one time programmable memory). UICR Program state is accessed from Program state by writing specific values to register 0x01. Registers 0x02 and 0x03 are where bit programming definition and triggering of UICR EFUSE programming can take place. See [UICR program usage](#) on page 14 for more details about UICR programming.

The SPI register interface is described in detail in [SPI interface](#) on page 15.

State	Symbol	Description
Power-down	PD	The device is in Power-down state.
Program	PG	The device can be configured and set to other states.
UICR program	UICR	User defined initialization values for POUTA_SEL, POUTA_UICR, POUTB_SEL, and POUTB_UICR can be configured to UICR.
Receive	RX	The RX path is enabled.
Transmit	TX	The TX path is enabled.

Table 4: Operating states description

ANT_SEL selects which of the two antenna interfaces is used during RX or TX. Antenna interface control is specified in [Table 5: Antenna switch control with ANT_SEL in different states](#) on page 12.

State	ANT_SEL	Description
Power-down	X	Antenna switches disabled (i.e. isolating)
Program	X	Antenna switches disabled (i.e. isolating)
UICR program	X	Antenna switches disabled (i.e. isolating)
Receive	0	ANT1 enabled, ANT2 disabled
	1	ANT1 disabled, ANT2 enabled
Transmit	0	ANT1 enabled, ANT2 disabled
	1	ANT1 disabled, ANT2 enabled

Table 5: Antenna switch control with ANT_SEL in different states

5.2 State transition timing

The following equation is used to define TPG→TRX when a slower SPI is used. Here it is assumed that there is a half SCK cycle gap between CSN and the first rising edge of SCK and the last falling edge of SCK and CSN.

Note: GPIO control is faster than SPI control.

$$T_{PG \rightarrow TRX} = \left(12.5 + 16.5 \cdot \left(\frac{1}{F_{SCK} [\text{MHz}]} - \frac{1}{8} \right) \right) \mu\text{s}$$

Figure 3: Defining TPG to TRX with slower SPI

Settling time requirements when switching between operational states are defined in [Table 6: Settling times](#) on page 13. An 8 MHz SCK clock must be used with SPI to obtain the timing given in the following table.

Symbol	Parameter	Note	Max.	Unit
$T_{PD \rightarrow PG}$	Settling time from state PD to PG	Triggered by PDN	17.5	μs
$T_{PG \rightarrow TRX}$	Settling time from state PG to TX or RX	Triggered by RX_EN, TX_EN, or SPI register write	12.5	μs
$T_{TRX \rightarrow PG}$	Power-off time when changing from RX or TX to PG	Triggered by RX_EN, TX_EN, or SPI Reg 0x0 write	5	μs
$T_{PG \rightarrow PD}$	Settling time from state PG to PD	Triggered by PDN	10	μs

Table 6: Settling times

When the device is in the Receive state, CSN pin needs to be driven low. An example of RX timing using an RX_EN pin-based configuration is shown in the following figure.

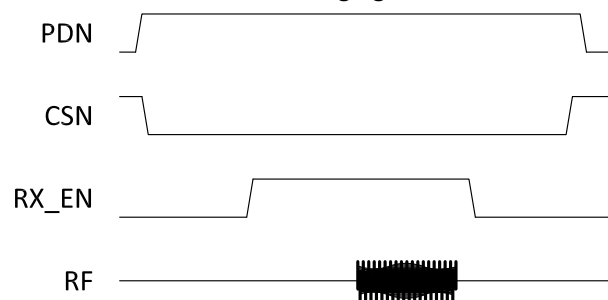

Figure 4: Control pin controls state change

The following figure shows the Transmit state configured using SPI.

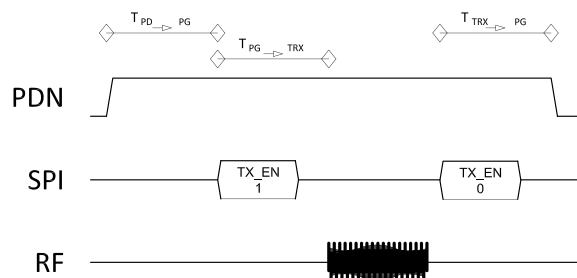

Figure 5: SPI controls state change

5.3 TX power control

The output power for the Transmit state can be configured using either pin control or the SPI interface.

To configure the output power through pins, the MODE pin or register 0x00 can be used to set TX power control to one of two preset values. Preset values are used to update the TX_Gain value when the MODE pin control changes in the Program state. Preset values can be set in UICR and selected. [Table 7: TX power control](#) on page 14 presents the TX_Gain initialization functionality.

The SPI interface can also be used to control the output power. Before entering the Transmit state, TX Gain is configured by writing the gain value over SPI to register 0x00 TX_Gain field. SPI write will always overwrite the initialization value. The Gain word can be set in the same write cycle when TX is enabled in the Program state.

Note: Gain should not be changed while the device is in the Transmit state.

If TX_Gain is modified through SPI, and TX is not enabled (i.e. Reg 0x00: TX_EN = 0), toggling the MODE bit in Reg 0x00 will change register TX_Gain field content to preset values. If SPI write sets TX_Gain at the same time TX_EN is set to 1, and the MODE bit in Reg 0x0 is not toggled at the same write, it does not matter if MODE has been toggled before. The SPI written value for TX_Gain will be used in the Transmit state. If SPI write sets the MODE bit to toggle at the same time TX_EN is set to 1, the preset TX_Gain value will be used in the Transmit state.

The following table shows TX power control with MODE control and corresponding preset values of TX_Gain in program state.

MODE	POUTA_SEL	POUTB_SEL	TX_Gain	Description
0	0	X	POUTA_PROD	Chip production default value used
1	X	0	POUTB_PROD	Chip production default value used
0	1	X	POUTA_UICR	End-user default value used
1	X	1	POUTB_UICR	End-user default value used

Table 7: TX power control

5.4 UICR program usage

The UICR program state enables the automated programming sequence for UICR EFUSE cell.

The automated programming sequence can be utilized in the following manner:

1. Apply VDD supply voltage using the specifications set in the following table.

Parameter	Min.	Max.
V _{DD}	3.45 V	3.60 V
T _{OP}	0°C	85°C

Table 8: EFUSE programming conditions

2. Set device to UICR Program state by sequentially writing 0x04 (UICR_EN = 1) and 0xF0 to register CONFREG1.
3. Write desired configuration values to register 0x03 for POUT_B_Sel and POUTB_UICR.
4. Write desired configuration values for POUTA_Sel and POUTA_UICR to register 0x02. Write a 1 to WR_UICR in register 0x02.
5. Wait for at least 0.5 ms to guarantee successful programming.
6. Reset the circuit by setting PDN to 0 and then back to 1.

The programmed values are now set for register 0x02 and 0x03. The device can be set to UICR mode for reading registers 0x02 and 0x03 to verify programmed values.

6 SPI interface

SPI registers are one byte long. The data transitions for slave in and out (MOSI and MISO) happen on the falling edge of the serial clock (SCK).

Input data is sampled on the rising edge of SCK, starting with the first rising edge. Therefore, it is required that the first bit is stable on the first rising clock edge of SCK. Common definitions for SPI bus are CPOL = 0 and CPHA = 0. The serial data frame is 16 bits long and consists of three parts in transmission order: command (Cmd), address, and data. All fields are sent on MOSI line MSB first. In the event of a write operation, a command is 2 bits long, an address is 6 bits long, followed by 8 bits of data. CSN is active low and it is assumed that it is set to 0 at least half a SCK cycle before the first rising edge of SCK, and then again to logical 1 earliest after half a cycle of 16th SCK falling edge.

The following commands are used:

- READ, b10 – This command allows reading of registers. The register address to read from is sent after the command. The read data will be clocked out to the MISO line during the data part of the SPI frame.
- WRITE, b11 – This command allows writing to registers. The last 8 bits sent on the MOSI line will be written to a register pointed with 6-bit address field. The write command has writeback property. When a register is accessed by the write command to update its value, the previous register value will be written to MISO line in serial format MSB first.

[SPI timing specification](#) presents the required timings between CSN signal and SCK edge.

[Figure 6: SPI write configuration example](#) on page 15 shows a configuration example for SPI when writing to register 0x00. Command b11 is written to the command field. The first bit on the MOSI line shall be set to its value (in this case to 1) before the first rising edge of SCK occurs, since Cmd is read on the rising edge of the first and second SCK cycle. SCK rising edges 3 to 8 are used to read the address field and 9 to 16 read the data field. Register 0x00 writeback data is written on the MISO line starting on the falling edge of cycle 8 so that cycle 9 to 16 rising edges can be used to read in MISO data on the Master side. Guaranteed settling time for the first read bit before the cycle 9 falling edge can be found in [SPI timing specification](#).

Functionality of the read operation is similar to writeback, meaning that read data is written to the MISO line starting on the cycle 8 falling edge when the read command is given in the Cmd field.

An overview of register address space and accessibility of registers in different operation states is found in [SPI timing](#).

The detailed register map is given in the [Register interface](#) on page 19.

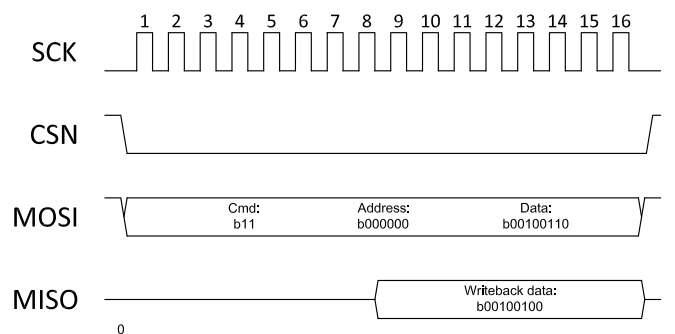

Figure 6: SPI write configuration example

Register address	Function	Accessible via SPI
0x00	TX state control and TX gain control in Program state	PG, RX, TX, UICR
0x01	RX state control and RX gain control in Program state	PG, RX, TX, UICR
0x02, 0x03	UICR programming interface registers	UICR
0x14, 0x15[7:4]	Part number, hardware revision	PG
0x16, 0x17	Hardware ID	PG

Table 9: Register overview and accessibility in different operation states

7 Electrical specification

The device is calibrated at 25°C to VDD = 3.0 V.

Unless otherwise stated, the following conditions apply:

- VDD = 3.0 V
- $Z_L = 50 \Omega$
- $P_{IN_TRX} = 0 \text{ dBm}$

7.1 Electrical specification

7.1.1 Current consumption

Symbol	Description	Min.	Typ.	Max.	Units
I_{PD}	State: PD		30	..	nA
I_{PG}	State: PG		0.7	..	mA
I_{RX}	State: RX		4.1	..	mA
I_{TX_10dBm}	State: TX $P_{OUT} = 10\text{dBm}$		42	..	mA
I_{TX_20dBm}	State: TX $P_{OUT} = 20\text{dBm}$		115	..	mA

7.1.2 RX

Symbol	Description	Min.	Typ.	Max.	Units
f	Operating frequency range	2360		2500	MHz
G_{RX}	Gain		13		dB
NF_{RX}	Noise figure		2.5		dB
P_{1dB}	Input 1 dB compression point (single tone CW)	-18.0	-13.5		dBm
$IMD3_{-50dBm}$	Two tone IMD at -50dBm Two tone CW, f0: 2440 MHz, f1: +/- 3 MHz, f2: +/- 6 MHz		-109		dBm
$IMD3_{-30dBm}$	Two tone IMD at -30dBm Two tone CW, f0: 2440 MHz, f1: +/- 3 MHz, f2: +/- 6 MHz		-75		dBm
$H2_{RX}$	Harmonic 2nd (CW, -10 dBm)		-20		dBm
$H3_{RX}$	Harmonic 3rd (CW, -10 dBm)		-17		dBm
S_{11_ANTdB}	ANT port input reflection (over input frequency, 50 Ω)		-10.0	-8.4	dB
S_{22_TRXdB}	TRX port output reflection (over input frequency, 50 Ω)		-12.0	-10.6	dB
A_{RX_2GHz}	Out-of-band gain (at 2 GHz)		5.0	6.0	dB
A_{RX_3GHz}	Out-of-band gain (at 3 GHz)		5.0	6.0	dB
$P_{MAX,RX}$	Maximum output power (at TRX, $P_{IN} = 0 \text{ dBm}$)		2.5	5.0	dBm

7.1.3 TX

Symbol	Description	Min.	Typ.	Max.	Units
f	Input frequency range	2360		2500	MHz

Symbol	Description	Min.	Typ.	Max.	Units
P _{SAT}	Saturated output power; GFSK/OQPSK modulation		21.5		dBm
G _{TX}	Gain (P _{OUT} <P _{P1dB})		20		dB
P _{P1dB}	Output power in 1dB compression; GFSK/OQPSK modulation		21		dBm
AM/AM	Compression - positive		6		dB
AM/AM	Compression - negative		0		dB
T _{carrier}	Carrier switching time			1	µs
	P _{OUT} from -30 dBm to +20 dBm				
P _{SPUR2MHz}	In-band spurious emissions 2 MHz (GFSK/OQPSK)			-26	dBm
P _{SPUR3MHz}	In-band spurious emissions 3 MHz (GFSK/OQPSK)			-36	dBm
H2, H3	Harmonic, 2nd, 3rd; RBW = 1.0 MHz			-42	dBm
H4, H5	Harmonic, 4th, 5th; RBW = 1.0 MHz			-36	dBm
S _{11_TRXdB}	Input reflection at TRX pin (over input frequency range, 50 Ω)		-10	-7	dB
VSWR _{STB}	Unconditionally stable				-
VSWR _{RGN}	No permanent damage (load 10:1, all phase angles)				-

7.1.4 SPI timing specification

Symbol	Description	Min.	Typ.	Max.	Units
T _{SCK}	SCK clock period (50% duty cycle)	125			ns
T _{CSN-SCK1}	CSN lead time	62.5			ns
	Time from CSN set to 0 to first rising edge at SCK				
T _{SCK16-CSN}	CSN trail time	62.5			ns
	Time from 16th falling edge at SCK to CSN set to 1				
T _{CSN}	CSN idle time	125			ns
	Time required between consecutive transmissions				
T _{S_MISO}	MISO settling time	30			ns
	Guaranteed settling margin for MISO before 9th rising edge at SCK				

8 Register interface

8.1 Registers

Base address	Peripheral	Instance	Description	Configuration
0x00000000	REGIF	REGIF	Register interface	

Table 10: Instances

Register	Offset	Description
CONFREG0	0x0	Configuration register 0
CONFREG1	0x1	Configuration register 1
CONFREG2	0x2	Configuration register 2
CONFREG3	0x3	Configuration register 3
PARTNUMBER	0x14	
HW_REVISION	0x15	
HW_ID0	0x16	
HW_ID1	0x17	

Table 11: Register overview

8.1.1 CONFREG0

Address offset: 0x0

Configuration register 0

Bit number	7	6	5	4	3	2	1	0
ID	C	C	C	C	C	B	A	
Reset 0x00	0	0	0	0	0	0	0	0

ID	Acce Field	Value ID	Value	Description
A	RW TX_EN			TX enable
		Disable	0	TX mode disabled
		Enable	1	TX mode enabled
B	RW MODE			Select preset value of TX output power.
		0	0	TX_Gain = POUTA
		1	1	TX_Gain = POUTB
C	RW TX_GAIN			TX gain control (0: minimum, 31: maximum)

Initialized with value from POUTA or POUTB. See CONFREG2 and CONFREG3.

8.1.2 CONFREG1

Address offset: 0x1

Configuration register 1

Bit number					7	6	5	4	3	2	1	0
ID					E	E	E	E	C	A		
Reset 0x00					0	0	0	0	0	0	0	0
ID	Acce	Field	Value ID	Value	Description							
A	RW	RX_EN	Disable	0	RX enable							
			Enable	1	RX mode disabled							
C	RW	UICR_EN	Disable	0	RX mode enabled							
			Enable	1	UICR program mode enable							
E	RW	KEY	Enter	15	UICR program mode enter/leave key							
			Leave	0	Set to 0xF when enabling UICR program mode							
					Set to 0x0 when leaving UICR program mode							

8.1.3 CONFREG2

Address offset: 0x2

Configuration register 2

Bit number					7	6	5	4	3	2	1	0
ID					D	B	A	A	A	A		
Reset 0x00					0	0	0	0	0	0	0	0
ID	Acce	Field	Value ID	Value	Description							
A	RW	POUTA_UICR			User defined initialization value for POUTA (0: minimum - PA disabled, 31: maximum)							
B	RW	POUTA_SEL	0	0	TX_Gain initialized with POUTA_PROD (20 dBm +/- 0.25 dBm)							
			1	1	TX_Gain initialized with POUTA_UICR							
D	RW	WR_UICR	0	0	Write UICR memory							
			1	1	EFUSE idle							
					EFUSE write							

8.1.4 CONFREG3

Address offset: 0x3

Configuration register 3

Bit number					7	6	5	4	3	2	1	0
ID						B	A	A	A	A		
Reset 0x00					0	0	0	0	0	0	0	0
ID	Acce	Field	Value ID	Value	Description							
A	RW	POUTB_UICR			User defined initialization value for POUTB (0: minimum - PA disabled, 31: maximum)							
B	RW	POUTB_SEL	0	0	TX_Gain initialized with POUTB_PROD (10 dBm +/- 1.00 dBm)							
			1	1	TX_Gain initialized with POUTB_UICR							

8.1.5 PARTNUMBER

Address offset: 0x14

Bit number							7	6	5	4	3	2	1	0
ID							A	A	A	A	A	A	A	A
Reset 0x0C							0	0	0	0	0	1	1	0
ID	Access	Field	Value ID	Value	Description									
A	RW	PARTNUMBER			Part identification number									

8.1.6 HW_REVISION

Address offset: 0x15

Bit number							7	6	5	4	3	2	1	0
ID							B	B	B	B				
Reset 0x10							0	0	0	0	1	0	0	0
ID	Access	Field	Value ID	Value	Description									
B	RW	HW_REVISION			HW revision code									

8.1.7 HW_ID0

Address offset: 0x16

Bit number							7	6	5	4	3	2	1	0
ID							A	A	A	A	A	A	A	A
Reset 0x01							0	0	0	0	0	0	0	1
ID	Access	Field	Value ID	Value	Description									
A	RW	HW_ID0			Hardware ID									

8.1.8 HW_ID1

Address offset: 0x17

Bit number							7	6	5	4	3	2	1	0
ID							A	A	A	A	A	A	A	A
Reset 0x85							1	0	0	0	0	0	1	0
ID	Access	Field	Value ID	Value	Description									
A	RW	HW_ID1			Hardware ID									

9 Hardware and layout

9.1 Pin assignments

The pin assignment figure and tables describe the pinouts for the device. There are also recommendations for how the GPIO pins should be configured, in addition to any usage restrictions.

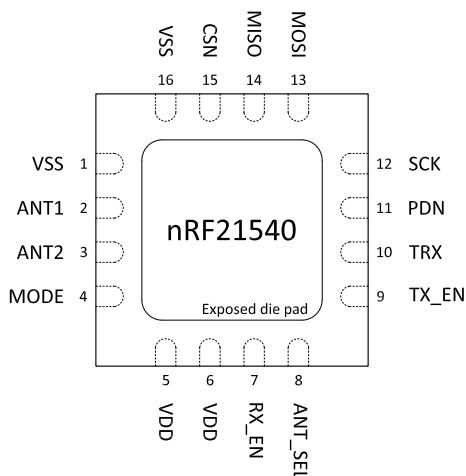

Figure 7: QFN16 pin assignments, top view

Pin number	Pin name	Type	Description
1	VSS	Power	Ground
2	ANT1	RF I/O	First antenna interface
3	ANT2	RF I/O	Second antenna interface
4	MODE	Digital IN	TX power mode control
5	VDD	Power	Supply voltage
6	VDD	Power	Supply voltage
7	RX_EN	Digital IN	RX mode enable
8	ANT_SEL	Digital IN	Antenna select
9	TX_EN	Digital IN	TX mode enable
10	TRX	RF IO	Transceiver interface
11	PDN	Digital IN	Power-down, active low
12	SCK	Digital IN	SPI clock Connect to VSS if SPI interface is not used
13	MOSI	Digital IN	SPI data in Connect to VSS if SPI interface is not used
14	MISO	Digital OUT	SPI data out Leave unconnected if SPI interfaces is not used
15	CSN	Digital IN	SPI chip select, active low Connect to VDD if SPI interface is not used
16	VSS	Power	Ground
DAP	VSS	Power	Ground

Table 12: Pin assignments

9.2 Reference circuitry

The reference circuitry schematic shows the application schematic.

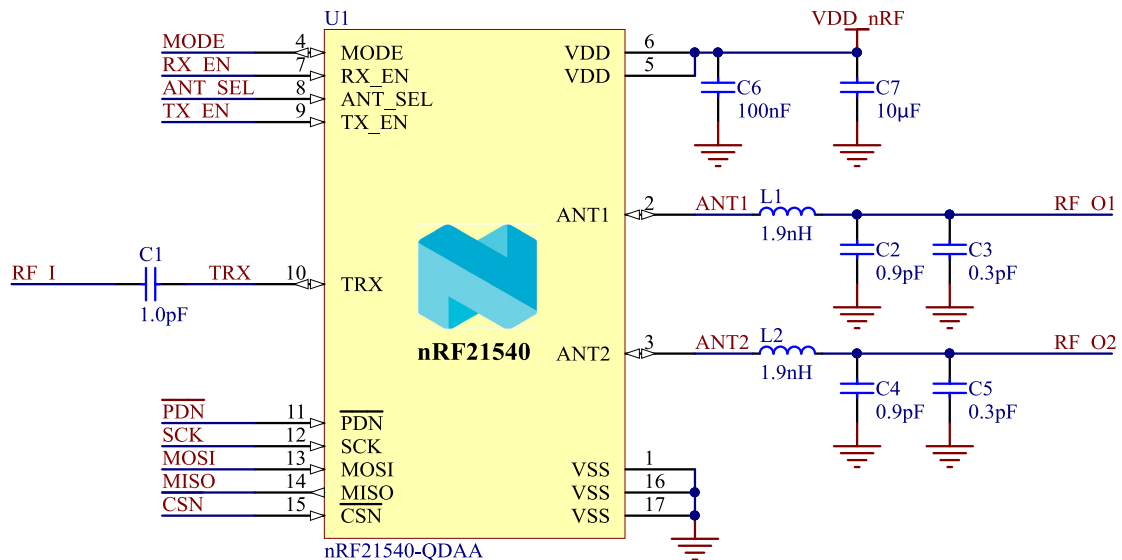

Figure 8: Reference circuitry schematic

The following table lists the recommended and tested component types and values.

Designator	Value Alt. 1	Value Alt. 2	Description	Footprint
C1	1.0 pF		Capacitor, NP0, ±5%	0201
C2, C4	1.2 pF	0.9 pF	Capacitor, NP0, ±5%	0201
C3, C5	N.C.	0.3 pF	Capacitor, NP0, ±5%	0201
C6	100 nF		Capacitor, X7S, ±10%	0201
C7	10 µF		Capacitor, X7S, ±20%	0603
L1, L2	1.9 nH		High frequency chip inductor ±5%	0201
U1	nRF21540-QDAA		Radio front-end /range extender for 2.4 GHz	QFN-16

Table 13: Bill of material for QFN16

Note: For increased third harmonic suppression, chose value alternative 2 from the table.

10 Recommended operating conditions

The operating conditions are the physical parameters that the chip can operate within.

Symbol	Parameter	Notes	Min.	Nom.	Max.	Units
VDD	Main supply voltage/battery	Functional range	1.7	3.0	3.6	V
V _{IH}	Digital input high	SPI, PDN, ANT_SEL	0.7 V _{VDD}		V _{VDD}	V
V _{IL}	Digital input low	SPI, PDN, ANT_SEL	V _{VSS}		0.3 V _{VDD}	V
F _{SCK}	SPI clock frequency	Exceeding may cause SPI malfunction			8	MHz
C _{MISO}	MISO load capacitance	Exceeding may cause SPI read malfunction			50	pF
T _{OP}	Operating temperature range	Board temperature, 1 mm from the package	-40	+25	+105	°C
Z _L	Load impedance			50		Ω

Table 14: Recommended operating conditions

11 Absolute maximum ratings

Maximum ratings are the extreme limits to which the chip can be exposed to for a limited amount of time without permanently damaging it. Exposure to absolute maximum ratings for prolonged periods of time may affect the reliability of the device.

	Note	Min.	Max.	Unit
Supply voltage				
VDD		0	3.6	V
VSS			0	V
Digital I/O pin voltage				
V _{I/O}	VDD ≤ 3.6 V	-0.3	VDD + 0.3	V
RF I/O pin voltage				
V _{ANT}		TBD	TBD	V
V _{TRX}		TBD	TBD	V
RF I/O pin input power				
P _{IN_TRX}	CW, Transmit mode		+5	dBm
P _{IN_ANT}	CW, Receive/Program mode		+15	dBm
Environmental				
Storage temperature		-40	125	°C
Reflow soldering temperature	IPC/JEDEC J-STD-020		260	°C
MSL	Moisture sensitivity level			
ESD HBM	Human Body Model		2	kV
ESD CDM	Charged Device Model		1	kV

Table 15: Absolute maximum ratings

